

Errata

Title & Document Type: 3488A Switch/Control Unit
Operating, Programming, and Configuration Manual

Manual Part Number: 03488-90000

Revision Date: October 1, 1983

HP References in this Manual

This manual may contain references to HP or Hewlett-Packard. Please note that Hewlett-Packard's former test and measurement, semiconductor products and chemical analysis businesses are now part of Agilent Technologies. We have made no changes to this manual copy. The HP XXXX referred to in this document is now the Agilent XXXX. For example, model number HP8648A is now model number Agilent 8648A.

About this Manual

We've added this manual to the Agilent website in an effort to help you support your product. This manual provides the best information we could find. It may be incomplete or contain dated information, and the scan quality may not be ideal. If we find a better copy in the future, we will add it to the Agilent website.

Support for Your Product

Agilent no longer sells or supports this product. You will find any other available product information on the Agilent Test & Measurement website:

www.tm.agilent.com

Search for the model number of this product, and the resulting product page will guide you to any available information. Our service centers may be able to perform calibration if no repair parts are needed, but no other support from Agilent is available.

3488A SWITCH/CONTROL UNIT

OPERATING,
PROGRAMMING,
AND CONFIGURATION
MANUAL

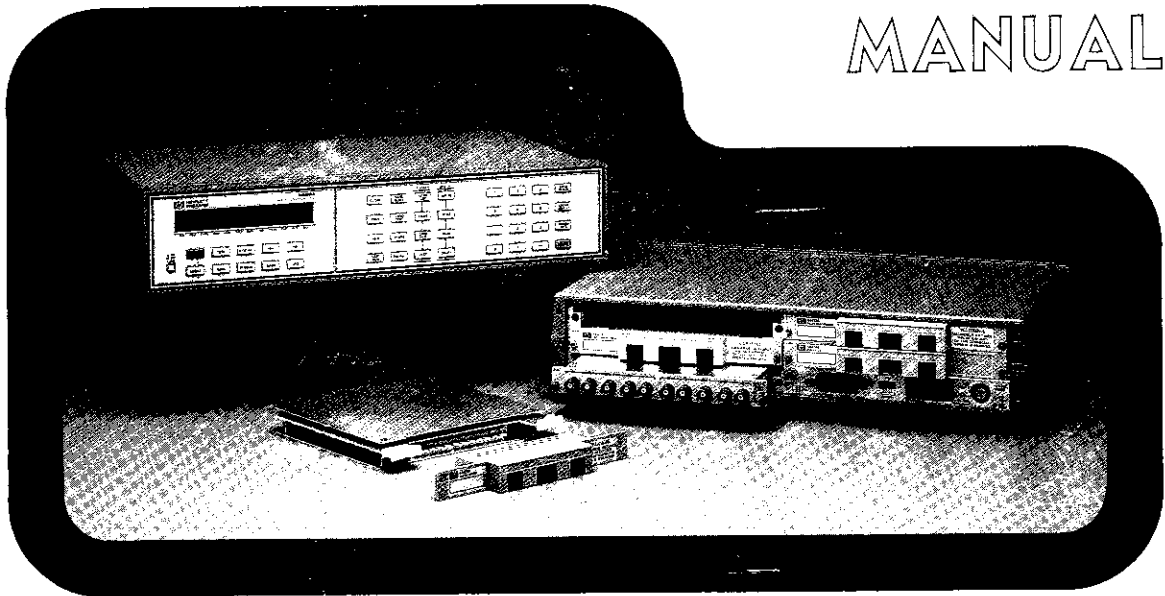

HEWLETT
PACKARD



HEWLETT
PACKARD

OPERATING, PROGRAMMING AND CONFIGURATION MANUAL

MODEL 3488A SWITCH/CONTROL UNIT

IMPORTANT NOTICE

Any changes made in instruments manufactured after this printing will be found in a "Manual Changes" supplement supplied with this manual. Be sure to examine this supplement, if one exists for this manual, for any changes which apply to your instrument and record these changes in the manual.

WARNING

The 3488A uses latching relays on the 44470A, 44471A, 44472A, and 44473A Option assemblies. The state of these relays can only be altered under front panel or program control. This is an advantage in the sense that, under most conditions of failure, the relays will remain in whatever state your program has set them. However, in the case of power or equipment failure, any application requiring a failsafe method of insuring that the circuits under control are in a known state must be provided by the installer.

In case of component failure or programming error, any voltage input to an option card may be present on any other terminal on the same option card.

WARNING

If any of the following symptoms exists, or are even suspected, remove the instrument from service. Do not use the instrument until safe operation can be verified by service-trained personnel.

- 1. Visible damage.*
- 2. Severe transport stress.*
- 3. Prolonged storage under adverse conditions.*
- 4. Failure to perform intended measurements.*

If necessary, return the instrument to a Hewlett-Packard Sales and Service Office for service and repair to ensure that safety features are maintained.

Manual Part No. 03488-90000

Microfiche Part No. 03488-90050

©Copyright Hewlett-Packard Company 1983
P.O. Box 301, Loveland, Colorado, 80537 U.S.A.

How To Use This Manual

This Operating, Programming and Configuration Manual has been designed as both a tutorial operating manual for the 3488A and a reference manual for each of the 3488A options. You will find concise operating and programming information in the first four chapters. Chapter 5 shows you how to install your 3488A and also provides specification and warranty information.

The last half of this manual is composed of six chapters, one for each of the six 3488A option assemblies. These option reference chapters provide installation and configuration information for qualified service-trained personnel. Option dependent programming information is also provided for each option.

Finally, to help you in setting up your test or measurement system, two appendices have been included. The first helps you document your test system. The second, gives a technical description of the HP-IB interface.

Here is an overview of what this manual contains:

▶ **Meet the 3488A Switch/Control Unit, Chapter 1 (Page 1)**

This chapter is designed to get you familiar with the 3488A. It describes the major features of the 3488A and the six different option assemblies available for the 3488A.

▶ **Using the 3488A, Chapter 2 (Page 21)**

Chapter 2 teaches you how to operate your 3488A. Remote programming as well as front panel operation is discussed. Several exercises are provided to enhance the discussion.

▶ **More Functions and Features, Chapter 3 (Page 51)**

In Chapter 3 you will learn to use the more advanced features of the 3488A. This includes scanning through a list of channels, pairing option assemblies together, and much more.

▶ **Advanced Remote Programming, Chapter 4 (Page 79)**

As the title says, this chapter deals with topics in advanced remote programming. Chapter 4 shows you how to increase throughput or program the 3488A to interrupt the system computer for any of a number of specific reasons. Program examples are given to enhance the discussion.

▶ **Operator Information, Chapter 5 (Page 95)**

Instructions for installing the 3488A, specifications, accessories, warranty information and much more is discussed in Chapter 5. You will need to read Chapter 5 before doing initial 3488A installation.

▶ **Option Reference Chapters (Chapters 6 - 11)**

Each of these chapters is devoted to one of the 3488A option assemblies and provides information unique to that option. Specific programming information is given with many application examples. In addition, complete installation and configuration procedures are provided.

▶ **Documentation Worksheet, Appendix A (Page 259)**

This simple worksheet will help you to plan your test system both with hardware wiring connections and when programming the system computer. Furthermore, it can be an aid in diagnosing system failures should they occur.

▶ **HP-IB, Appendix B (Page 265)**

HP-IB (IEEE 488-1978) is a carefully defined interface for instrumentation. This appendix gives a technical description of HP-IB for those unfamiliar with it.

The following chart shows chapters which are recommended reading for various types of 3488A users. You may fall into more than one category. For example, you may be an inexperienced programmer who installs the test system.

Reader/User	Chapters					Command Summary	Option Reference Chapters	Appendix A	Appendix B
	1	2	3	4	5				
Installation Personnel					•		•	•	•
First time user	•	•							
Advanced user		•	•				•	•	
Test System Programmer		•	•	•		•	•		

TABLE OF CONTENTS

Chapter	Page
1. Meet the 3488A.....	1
Introduction.....	1
The Options.....	1
Installation of Options.....	2
An Overview of the 3488A.....	3
Power-on Operations.....	5
Reset and Test.....	6
Determining Option Card Type.....	8
44470A.....	11
Description.....	11
Applications.....	11
44471A.....	12
Description.....	12
Applications.....	12
44472A.....	13
Description.....	13
Applications.....	13
44473A.....	15
Description.....	15
Applications.....	15
44474A.....	16
Description.....	16
Applications.....	17
44475A.....	18
Description.....	18
Applications.....	18

Chapter	Page
2. Using the 3488A.....	21
Introduction.....	21
Scope.....	21
Note on Remote HP-IB Programming.....	21
Trying a Command.....	23
Channel and Slot Definition.....	24
How to Close/Open a Channel.....	25
How to VIEW a Channel.....	27
How to Monitor an Entire Option Assembly.....	28
Monitoring a 44470A 10 Channel Multiplexer or 44471A General Purpose Relay Assembly.....	29
Monitoring a 44472A VHF Switch.....	30
Monitoring a 44473A Matrix Assembly.....	31
Monitoring a 44474A Digital I/O Assembly.....	33
Monitor Tracking.....	35
Resetting Individual Option Assemblies.....	36
Self Test.....	36
Using the Display.....	38
Handling Errors.....	39
Reading the Error Register.....	41
The STATUS Command.....	42
Using the Built-in Quick Reference Guide.....	44

Chapter	Page
3. More Functions and Features.....	51
Introduction.....	51

Storing and Recalling Channel Configurations.....	51
Scanning Through a List of Channels.....	53
Using the STEP Command.....	55
Using the CHAN Command.....	55
External Increment and Channel Closed.....	56
Card Pair.....	58
Using the Time Delay.....	59
COMMAND DIRECTORY.....	61

Chapter	Page
4. Advanced Remote Programming.....	79
Introduction.....	79
Using the 3488A Input Buffer.....	79
3488A HP-IB Capabilities.....	81
CLEAR.....	82
Examples.....	82
Comments.....	82
LOCAL.....	82
Examples.....	82
Comments.....	82
LOCAL LOCKOUT.....	83
Example.....	83
Comments.....	83
REMOTE.....	83
Examples.....	83
Comments.....	83
REQUEST SERVICE (SRQ).....	84
How to Use SRQ.....	84
Status Register and Status Byte.....	85
Setting the SRQ Mask.....	86
Example 1. Front Panel SRQ.....	87
Example 2. SRQ on End of Scan Sequence.....	88
SPOLL.....	91
Example.....	91
Comments.....	91
TRIGGER.....	94
Examples.....	94
Comments.....	94

Chapter	Page
5. Operator Information.....	95
Introduction.....	95
Preparation for Use.....	95
Unpacking Instructions.....	95
Initial Inspection.....	96
Power Requirements.....	96
Line Voltage Selection.....	97
Power Line Fuse Replacement.....	97
Grounding Requirements.....	98
Power Cords and Receptacles.....	98
Instrument Mounting.....	98
HP-IB Interface Connections.....	99
HP-IB Address Selection.....	99
Options and Accessories.....	101
Warranty Information.....	102
Certification.....	102
Warranty.....	102
Limitation of Warranty.....	102

Exclusive Remedies	103
Assistance	103
Limitation of Warranty for Option 015	103
Safety Summary	103
Specifications	105
Environmental Requirements	105
Miscellaneous	106
How to Obtain Repair Service	106
3488A Serial Number	106
General Shipping Instructions	106
Cleaning	106

Specifications	126
Applications	126
Example 1. 4-Wire Ohms	127
Example 2. Scanning Using Channel Closed	129
Example 3. Scanning Using External Increment and Channel Closed	130
Example 4. Single Ended Measurements	131

Chapter	Page
6. 44470A Relay Multiplexer	109
Introduction	109
Operation	109
Channels	110
Commands	111
CLOSE a channel	111
Description	111
Examples	111
OPEN a channel	112
Description	112
Example	112
VIEW a channel	112
Description	112
Example	112
CARD TYPE	113
Description	113
Example	113
CARD RESET	113
Description	113
Example	113
CARD PAIR	114
Description	114
Example	114
Example	114
SCAN LIST	115
Description	115
Example	115
Notes	115
STEPping Through the Scan List	116
Description	116
Example	116
CHANnel command	116
Description	116
Example	117
CARD MONITOR mode	117
Description	117
Example	117
Advanced Operations	118
External Increment and Channel Closed	118
DELAY	119
Description	119
Examples	120
HP-IB Interface Commands	120
44470A Assembly Installation	120
Configuration	125
Accessories	126

Chapter	Page
7. 44471A General Purpose Relay	
Introduction	135
Module	135
Operation	136
Channels	136
Commands	137
CLOSE a channel	137
Description	137
Examples	137
OPEN a channel	138
Description	138
Examples	138
VIEW a channel	138
Description	138
Example	138
CARD TYPE	139
Description	139
Example	139
CARD RESET	139
Description	139
Example	139
CARD PAIR	140
Description	140
Example	140
Example	140
SCAN LIST	141
Description	141
Example	141
Notes	141
STEPping through the Scan List	142
Description	142
Example	142
CHANnel Command	142
Description	142
Example	143
CARD MONITOR mode	143
Description	143
Example	143
Advanced Operations	144
External Increment and Channel Closed	144
DELAY	145
Description	145
Examples	146
HP-IB Interface Commands	146
44471A Assembly Installation	147
Configuration	151
Using Varistors	155
Accessories	155
Specifications	155

Application Examples	156
Example 1. Using the 44471A as an Actuator	156
Example 2. Using the 44471A as a Resistance Programmer	157
Example 3. Single Ended Measurements	159

Chapter	Page
8. 44472A Dual 4 – 1 VHF Switch Module	163
Introduction	163
Operation	164
Channels	164
Commands	165
CLOSE a channel	166
Description	166
Example	166
OPEN a channel	166
Description	166
Examples	166
VIEW a channel	167
Description	167
Example	167
CARD TYPE	167
Description	167
Example	168
CARD RESET	168
Description	168
Example	168
CARD PAIR	168
Description	168
Example	168
Example	169
SCAN LIST	169
Description	169
Example	169
Notes	169
STEPping through the Scan List	170
Description	170
Example	170
CHANnel Command	171
Description	171
Examples	171
CARD MONITOR mode	171
Description	171
Example	172
Advanced Operations	172
External Increment and Channel	
Closed	172
DELAY	174
Description	174
Examples	174
HP-IB Interface Commands	174
44472A Assembly Installation	175
Specifications	176
Applications	177
Isolation Impedance	177
Topologies	178

Chapter	Page
9. 44473A 4 × 4 Matrix Switch Module	183
Introduction	183
Operation	184
Channels	184
Commands	185
CLOSE a channel	186
Description	186
Examples	186
OPEN a channel	186
Description	186
Examples	186
VIEW a channel	187
Description	187
Example	187
CARD TYPE	187
Description	187
Example	188
CARD RESET	188
Description	188
Example	188
CARD PAIR	188
Description	188
Example	188
Example	189
SCAN LIST	189
Description	189
Example	189
Notes	190
STEPping through the Scan List	190
Description	190
Example	190
CHANnel Command	191
Description	191
Examples	191
CARD MONITOR mode	191
Description	191
Advanced Operations	193
External Increment and Channel	
Closed	193
DELAY	194
Description	194
Examples	195
HP-IB Interface Commands	195
44473A Assembly Installation	196
Accessories	200
Specifications	200
Applications	200
Example 1. Extending the Matrix	200
Example 2. Extending the Matrix to 4 × 40	205

Chapter	Page
10. 44474A Digital I/O Module	209
Introduction	209
Operation	210
Bit Definition	210
Commands	212
CLOSE a bit	213
Description	213
Examples	213

OPEN a Bit	214
Description	214
Example	214
VIEW a Bit	214
Description	214
Example	214
CARD RESET	215
Description	215
Example	215
CARD PAIR	215
Description	215
Example	215
Example	216
DIGITAL WRITE Command	216
Description	216
Example	216
Example	217
DIGITAL READ	218
Description	218
Example	219
CARD MONITOR Mode	219
Description	219
Example	219
DIGITAL MODE Command	220
Description	220
Mode Definition	220
Polarity Definition	225
External Increment Definition	226
SCAN LIST	227
Description	227
Example	228
Notes	228
STEPping Through the Scan List	228
Description	228
Example	229
CHANnel Command	229
Description	229
Examples	229
DELAY time	230
Description	230
Examples	230

DIGITAL BINARY WRITE	230
Description	230
Example	231
DIGITAL BINARY READ	231
Description	231
Example	232
HP-IB Interface Commands	232
44474A Assembly Installation	233
Accessories	237
Specifications	237
Applications	237
Example 1. Scanning Using External Increment and Channel Closed	237
Example 2. Limit Switch Sensing	239

Chapter	Page
11. 44475A Breadboard Assembly	241
Introduction and Description	241
Warranty	242
Getting Started	242
Specifications	242
Assembling the Breadboard	244
Loading the Components	244
Mounting Your Custom Circuitry	246
Component Height/Protrusion Restrictions	246
Using Wire-Wrap Components	
Lead Length	247
Breadboard Top and Bottom Edges	247
Power Supply and Ground Traces	247
Soldering	247
Assembling the Hardware	247
Breadboard Installation	248
Terminal Block	250
Controlling the Breadboard Ports	252
SREAD Command	252
SWRITE Command	253
APPENDICES	
A	259
B	265

LIST OF TABLES

Table	Page		
2-1.	Self Test Errors	37	
5-1.	Accessories	101	
5-2.	3488A General Specifications	107	
6-1.	Channel Addressing Scheme	111	
6-2.	Option 010 44470A 10 Channel Relay Multiplexer Module Specifications	134	
7-1.	Channel Addressing Scheme	137	
7-2.	Option 011 44471A 10 Channel General Purpose Relay Module Specifications	162	
8-1.	Channel Addressing Scheme	165	
8-2.	Option 012 44472A Dual 4 Channel VHF Switch Module Specifications	181	
9-1.	Channel Addressing Scheme	185	
9-2.	Option 013 44473A 4 × 4 Matrix Switch Module Specifications	207	
10-1.	Polarity Specifier	225	
10-2.	Option 014 44474A 16 Bit Digital I/O Module Specifications	239	
11-1.	Required Components for 8-bit I/O Ports	244	
11-2.	Parts Supplied With the 44465A Breadboard	247	
B-1.	3488A Bus Capabilities	269	
B-2.	HP-IB Worksheet	270	

LIST OF ILLUSTRATIONS

Figure	Page		Page
1-1.	10	44470A Simplified Schematic	7-13. High Voltage Actuator 157
1-2.	12	44471A Simplified Schematic	7-14. Binary Resistance Programming . . 158
1-3.	14	44472A Simplified Schematic	7-15. Voltage Divider 159
1-4.	15	44473A Simplified Schematic	7-16. Single-ended Measurements 160
1-5.	17	44474A Simplified Schematic	8-1. 44472A Simplified Schematic . . . 164
1-6.	19	Breadboard Interface Circuitry	8-2. Rear Panel View of the 3488A . . . 176
2-1.	29	Simplified Schematic for 44470A and 44471A	8-3. Option Card 177
2-2.	30	Simplified Schematic for 44472A	8-4. Two 44472A's in "T" Configuration 179
2-3.	32	44473A Simplified Schematic	8-5. 4 × 4 Matrix 179
2-4.	35	44474A Simplified Schematic	8-6. Tree Configuration 180
2-5.	42	Status Byte	9-1. 44473A Simplified Schematic . . . 184
3-1.	59	Delay Timing	9-2. Rear Panel View of the 3488A . . . 197
4-1.	85	Status Byte and SRQ Mask	9-3. Option Card 198
4-2.	89	3488A Channel Scanning	9-4. Terminal Block 198
4-3.	91	Status Byte	9-5. Strain Relief Assembly 199
5-1.	97	AC Line Voltage Selection Switch	9-6. Cable Routing 199
5-2.	98	Power Cords	9-7. 4 × 8 Matrix 201
5-3.	99	Typical HP-IB System Interconnection	9-8. 4 × 12 Matrix 202
5-4.	100	3488A HP-IB Address Codes	9-9. 4 × 16 Matrix 203
6-1.	110	44470A Simplified Schematic	9-10. 4 × 20 Matrix 204
6-2.	122	Rear Panel View of the 3488A	9-11. 8 × 8 Matrix 205
6-3.	122	Option Card	9-12. 4 × 40 Matrix 206
6-4.	123	Terminal Block	10-1. 44474A Simplified Schematic . . . 210
6-5.	123	Strain Relief Housing	10-2. Output Bit Simplified Drawing . . . 211
6-6.	124	Cable Routing	10-3. Input Bit Simplified Drawing 212
6-7.	124	Attaching the Terminal Block	10-4. Scan Timing 227
6-8.	125	Diagram of simple Attenuator	10-5. Rear Panel View of the 3488A . . . 234
6-9.	126	Attenuator Board Locations	10-6. Option Card 234
6-10.	128	4-Wire Ohms Measurements	10-7. Terminal Block 235
6-11.	129	Channel Closed	10-8. Strain Relief Housing 235
6-12.	131	External Increment and Channel Closed	10-9. Cable Routing 236
6-13.	132	Single Ended Scanning	10-10. Attaching the Terminal Block . . . 236
7-1.	136	44471A Simplified Schematic	10-11. External Increment and Channel Closed 238
7-2.	148	Rear Panel View of the 3488A	10-12. Limit Switch Sensing 239
7-3.	149	Option Card	11-1. 44475A Breadboard 241
7-4.	149	Terminal Block	11-2. 44475A Breadboard Option Dimensions and Component Height/Protrusion Restrictions 243
7-5.	150	Strain Relief Housing	11-3. Component Mounting 245
7-6.	150	Cable Routing	11-4. Breadboard Schematic 246
7-7.	151	Attaching the Terminal Block	11-5. Hardware Assembly 249
7-8.	152	Contact Protection Networks	11-6. Rear Panel of the 3488A 250
7-9.	153	RC Protection Network	11-7. Strain Relief Housing 251
7-10.	154	Locations for Protection Networks	11-8. Cable Routing 251
7-11.	155	Varistor	11-9. Attaching the Terminal Block 252
7-12.	156	Low Voltage Actuator	A-1. Worksheet Examples 259
			B-1. HP-IB Interface 266

Chapter 1

Meet the 3488A

Switch/Control Unit

Introduction

Whether you are involved in large production test systems or small R&D bench systems, the 3488A Switch/Control Unit can make the task of signal switching much easier. The 3488A, with its various options, is designed to switch analog signals from low level voltmeter inputs to 250 @ 2A power supplies. The option assemblies can be combined for many topologies providing the combination you need for your test system.

Your 3488A is fully programmable from any HP-IB* compatible computer. But more than that, it has a full function keyboard complete with its own built-in quick reference guide.

Six option assemblies are available for the 3488A to cover many types of switching or control needs. All option assemblies, except for the VHF switch, are provided with a removable terminal block assembly for convenience in wiring. Any combination of up to five option assemblies can be installed in your 3488A. The assemblies are easy to install and can identify themselves to the 3488A front panel or the system computer.

The Options

Six Option assemblies are available for the 3488A including:

44470A A 10 Channel (2 wire) Relay Multiplexer provides high impedance for
Option 010 switching low level signals (with $< 3 \mu\text{V}$ differential offset) but can also
 switch high level signals (250V, 2A).

44471A A 10 Channel General Purpose Relay Module designed to cover miscella-
Option 011 neous switching needs, this module consists of 10 Single Pole Single
 Throw (SPST) relays, each capable of switching up to 250V @ 2A.

44472A A Dual 4 channel VHF Switch provides high frequency (DC to 300 MHz,
Option 012 usable to 500 MHz) switching. Crosstalk is -80 dB to 100 MHz and
 -60 dB to 300 MHz. BNC connectors are provided for coaxial systems.

* HP-IB (Hewlett-Packard Interface Bus) is Hewlett-Packard's implementation of IEEE Standard 488-1978 and ANSI MC1.1.

- 44473A A 4 channel by 4 channel (2 wire) Matrix Switch for those applications
Option 013 requiring a convenient way to connect a group of test instruments to multiple test points. Each channel is rated at 250V @ 2A.
- 44474A A 16 channel Digital Input/Output Module. Sixteen bidirectional data lines
Option 014 with a variety of handshake modes make up this option. All lines are TTL compatible. Use this card to sense limit switches, actuators for (up to 30 Vdc, 125 mA), or communication via a digital logic interface.
- 44475A A Breadboard for mounting custom designed circuits for use in a test
Option 015 system.

These options are described in more detail at the end of this chapter.

Installation of Options

When you initially received your 3488A from the factory, the option assemblies you ordered were not installed in the mainframe. In order to perform the examples given in this manual, the option assemblies should be installed before continuing. Instructions for qualified service-trained personnel to install and configure the option assemblies are found in the individual option reference chapters at the end of this manual.

An Overview of the 3488A

Back Panel



Serial Number Plate
(on cabinet bottom)

Power-on Operations

Before you apply ac power to the 3488A, check to be sure that the ac line voltage selection switch was set correctly and the proper fuse installed. For installation information, refer to Chapter 5 of this manual.

When the 3488A is turned on, it automatically executes a power-on reset sequence. This sequence includes the following steps:

1. Identify all option assemblies present and reset them (all relays open).
2. Reset all HP-IB interface functions (i.e., SRQ, TALK, REMOTE, etc. See Chapter 4).
3. Read the HP-IB address switches.
4. Set all parameters to default values (i.e., no scan list or card pair, Static mode on Digital I/O option, etc.).
5. Perform internal self test.
6. Assert power-on SRQ if enabled by rear panel switch (see Chapter 4).

After pressing the LINE switch, wait for the display to contain only a lazy "T" on the far left side. A "beep" will sometimes be heard as the 3488A power supplies turn on.

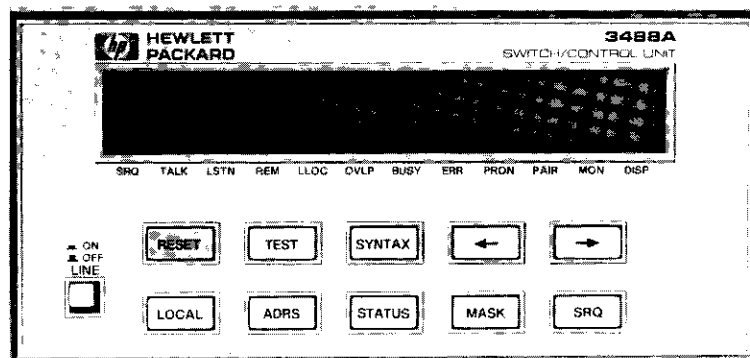

The entire power-on sequence takes approximately 2 seconds to complete. After this, while the instrument is operating, it will periodically (5 times per second) poll the five option slots to verify that all options are still in place. The 3488A will perform a complete power-on reset if an option has been removed or a new one inserted while the instrument is operating. This provides faster operation of the 3488A because it knows what options are in each of the slots and doesn't have to verify for the proper option each time a command is executed.

If an error is encountered during the turn on self test, a message would be displayed instead of the lazy T. This error message has the form: FAILED N, where N is the sum of the failures of the tests. Possible test results are:

- Test #1, RAM (Random Access Memory) Failure
- Test #2, ROM (Read Only Memory) Failure
- Test #4, Internal Timer Failure
- Test #8, IO Chip Failure

For example, FAILED 1 means that the RAM test failed, FAILED 3 means that both RAM and ROM tests failed. The self test is discussed in detail in Chapter 2.

In addition to the self test, several other failures are possible. At power-on, the 3488A will verify that all relays are open on 44470A, 44471A, and 44473A options after the instrument has been reset. If one or more relays did not open, the message "ERR 8: LOGIC" will be displayed. Error messages are also described in detail in Chapter 2.

Note that if the Power-On SRQ switch on the 3488A back panel is on, the PRON and SRQ annunciators will also be on in the display. Power-On SRQ is a means of signaling the computer that the 3488A has been turned on and is discussed in more detail in Chapter 4.

Reset and Test

At any time while you are using the 3488A, you can reset it to its turn on state by pressing the orange colored RESET button. The only things that are not changed are the stored states (see Chapter 3).

You can also perform the internal self tests by pressing the TEST button. When you do this, watch the display carefully. First, the display indicates the model number, then every segment in the display (except for the top dot on the colon between characters) turns on, including the annunciators.

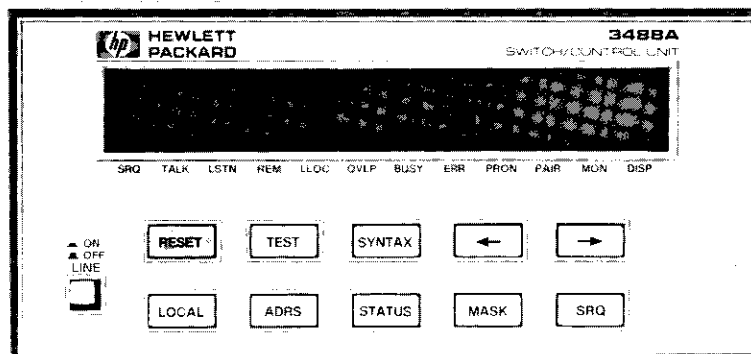

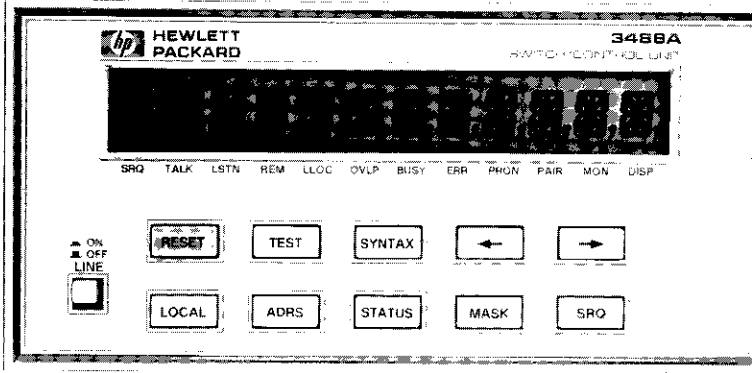

Following this "starburst" display, the internal self tests are run. When all tests pass, the message "SELF-TEST OK" appears in the display. Remember, the self test can be done at any time because no relay or digital I/O bits change state during the test.

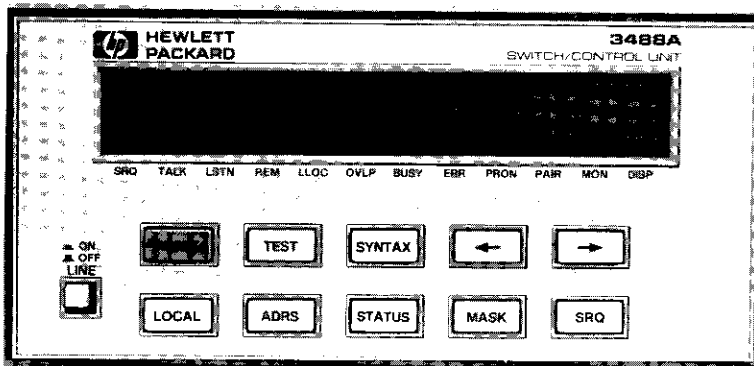

Should any of the tests fail, a message is displayed in the form "FAILED N" where N is the sum of all failures found in the series of tests. These internal self tests can greatly reduce initial troubleshooting time. More information on self test can be found in Chapter 2.

Determining Option Card Type

Throughout this manual, we will provide several examples showing the versatility and friendliness of the 3488A. This first example demonstrates how the display is used to hold messages and one of the keyboard functions: CARD TYPE.

CARD TYPE is provided so that you can determine the type of option assembly installed in any of the five 3488A slots. Be sure to write down what options are installed in each of the five slots. You will need this information as you perform the exercises throughout this manual.

To determine what option is in slot 1 of the 3488A, perform the following steps:

Press: 

The 3488A display will show:

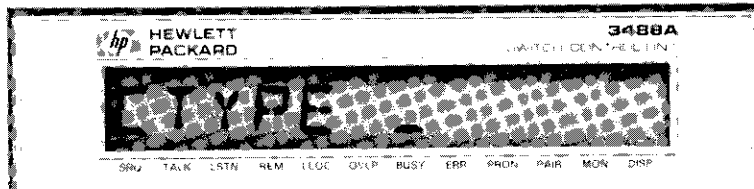

CTYPE is an acronym of CARD TYPE. The underline bar (cursor) means that the 3488A is waiting for a slot number. Since we want to investigate slot 1, press the numeric key 1.

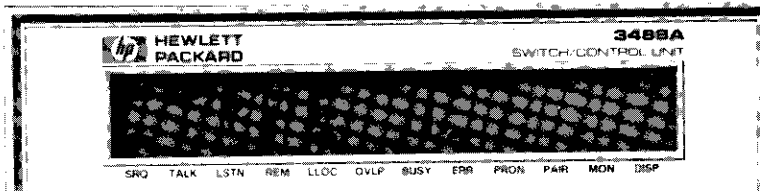

Now, press the execute key. 

The 3488A display should show the slot number on the far left followed by the name of the assembly installed in that slot. For example, if a 44470A 10 Channel Relay Multiplexer is installed in slot 1, the display will show:

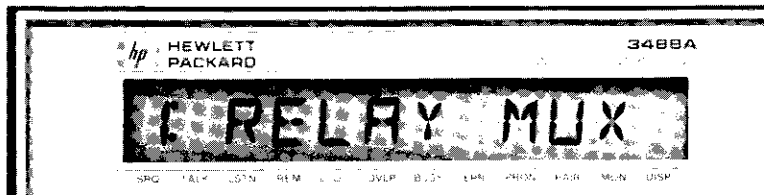

Now, press and hold the left arrow key to scroll the display window. The option assembly model number will appear in the display.

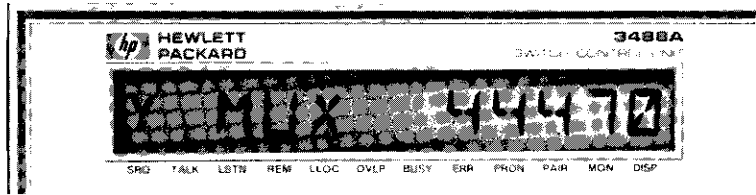

Now let's do the same for slots 2 through 5. Press the CARD TYPE key, a numeric key for the slot you want to investigate, followed by the Execute [EXEC] key. Don't forget to scroll the display and write down the type of option in each slot.

The following chart shows the responses for the six different option assemblies available for the 3488A as well as the display if no card is present in the specified slot.

Card Type	Display
Slot is empty	NO CARD 00000
10 CH. Relay Multiplexer	RELAY MUX 44470
10 CH. General Purpose	GP RELAY 44471
Dual 4 Channel VHF Switch	VHF SW 44472
4X4 Matrix Switch	MATRIX SW 44473
16 Bit Digital I/O	DIGITAL IO 44474
Breadboard	BREADBOARD 44475

The following BASIC language program, written for an -hp- Series 80 computer, shows how this same information can be obtained from the system computer. If you are not familiar with computer programming, Chapter 2 will show you how to begin programming to control the 3488A.

```

10 ! CARD TYPE PROGRAM
20 ! -HP- 85 VERSION
30 ! -HP- 3488A AT ADDRESS 709
40 DIM A$(16)
50 PRINT "SLOT          CARD TYPE" @ PRINT
60 FOR I=1 TO 5
70 OUTPUT 709 ;"CTYPE";I
80 ENTER 709 ; A$
90 PRINT TAB(2);I;TAB(10);A$
100 NEXT I
110 END

```

WARNING

The 3488A uses latching relays on the 44470A, 44471A, 44472A, and 44473A Option assemblies. The state of these relays can only be altered under front panel or program control. This is an advantage in the sense that, under most conditions of failure, the relays will remain in whatever state your program has set them. However, in the case of power or equipment failure, any application requiring a failsafe method of insuring that the circuits under control are in a known state must be provided by the installer.

In case of component failure or programming error, any voltage input to an option card may be present on any other terminal on the same option card.

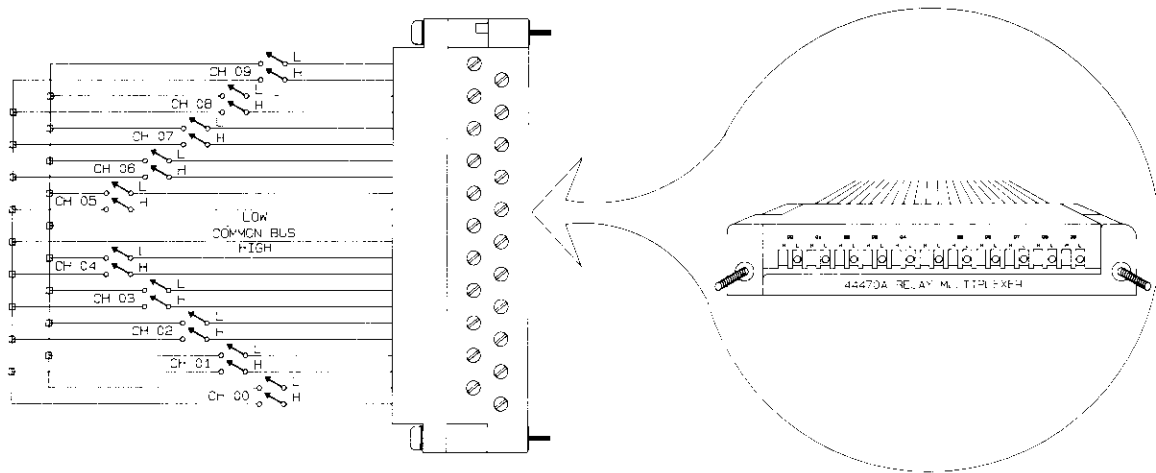

3488-1-1

Figure 1-1. 44470A Simplified Schematic

44470A

10 Channel Relay Multiplexer Option Option 010

Description

The -hp- Model 44470A (3488A Option 010) provides 10 channels to switch (multiplex) signals to a common point. Typically, the common point will be connected to some measuring device such as a voltmeter. In this case, the individual relays will connect to separate signal sources. Conversely, the common point may be connected to one signal source and each relay to a different test device.

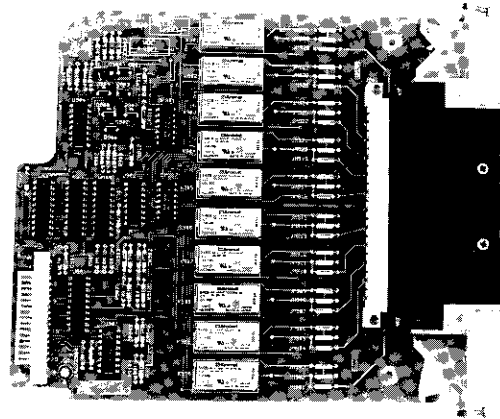

Each channel on this option consists of two sets of contacts (double pole - single throw). The relays have low thermal offset characteristics making them ideal for precision low level measurements. Multiple channel closures are allowed or it can be operated in a mode where only one relay is closed at a time (break-before-make).

Each relay is rated at 250V, 2A. A removable terminal block is provided for convenience in wiring and also provides strain relief for cables.

Applications

Figure 1-1 is a simplified schematic of the 44470A. Use this 10 channel multiplexer to switch analog signals to a DMM or other instruments. Low differential offset characteristics ensure accurate measurements on low level signals. In addition, this option has the capacity to switch high level signals up to 250V & 2A. Provisions are made on board for series/shunt components on each channel. Two 44470A options can be combined with the Card Pair function for performing 4-Wire resistance measurements.

44471A

10 Channel General Purpose Relay Module Option 011

Description

The General Purpose relay option contains 10 independent single pole, single throw switches. Two main uses for this option are providing independent signal switch contacts and use as an actuator* (to apply operating power to a device). Any combination of channels can be closed at any time.

All of the relays have low thermal offset characteristics making them ideal for independent (not multiplexed) signal switching. Space is provided on board for arc suppression components for switching inductive loads. A detachable terminal block that provides easy wire connections and strain relief is also provided.

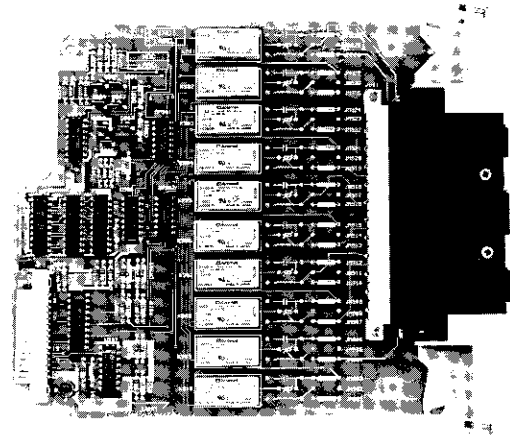

Applications

Use this option where non-multiplexed signal switching is needed. Because multiple channels can be closed sequentially, two channels can be used to switch signal High and Low. The option can also be used as an actuator for line voltage. Figure 1-2 is a simplified schematic of the option assembly.

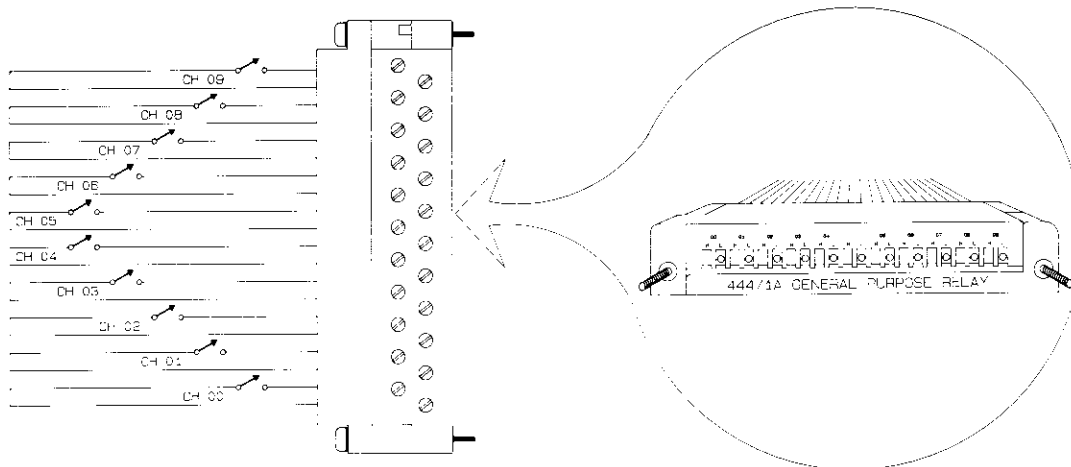

Figure 1-2. 44471A Simplified Schematic

*The 44474A Digital I/O option can also be used as an actuator with signals up to 125 mA and 30V.

44472A

Dual 4 Channel VHF Switch Option Option 012

Description

This option provides dual 4 channel coaxial multiplexers for broadband signal switching to 300 MHz (usable to 500 MHz). Cross talk is -80dB to 100 MHz and -60 dB from 100 MHz to 300 MHz ($50\ \Omega$ termination). The 2 groups of 4 channels are isolated from each other and from chassis ground to reduce ground loops. The shield (low) of each channel is common to its group of four channels.

Connections are made via BNC connectors mounted directly on the option.

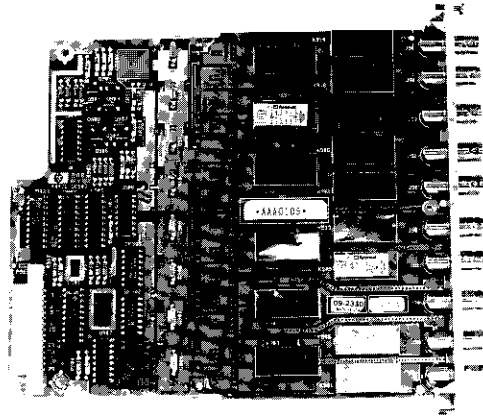

Applications

This option is excellent for high frequency signal where isolation and a $50\ \Omega$ characteristic impedance is important. Multiple options can be connected together forming various types of multiplexers. This option can also be used with pulse and digital circuits where signal integrity and fast rise time is important.

Almost anywhere BNC connectors are used, this option will find a place. It is ideal for wide dynamic range measurements with oscilloscopes or spectrum analyzers. The simplified functional schematic shown in Figure 1-3 shows both groups of channels.

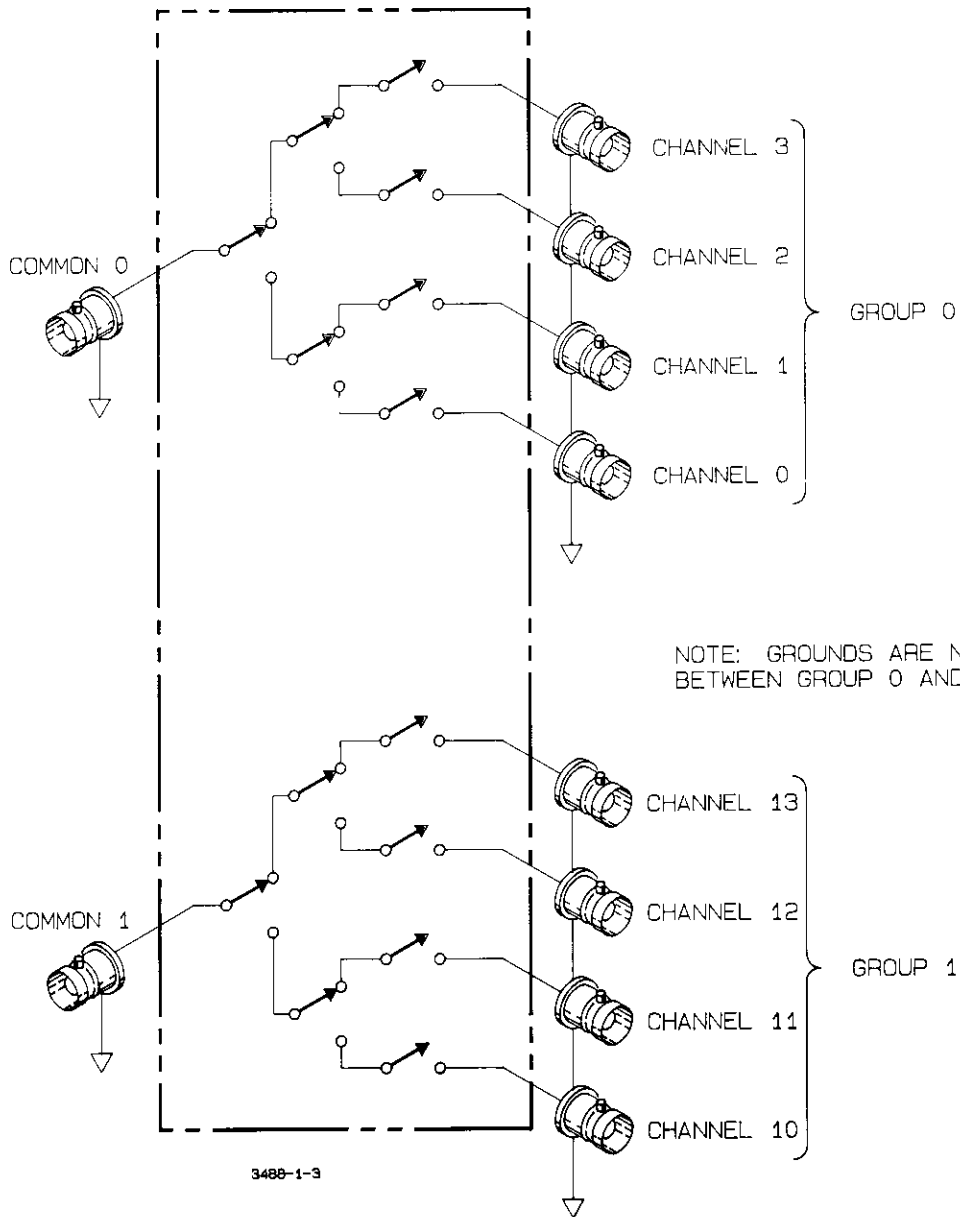

Figure 1-3. 44472A Simplified Schematic

44473A

4-by-4 Matrix Switch Option Option 013

Description

The 44473A is a 4X4 matrix with each switch in the matrix switching both signal high and signal low. Refer to the simplified schematic below. Any combination of the 4 "rows" may be connected to any combination of the 4 "columns".

Multiple 44473A Matrix Switch options can be combined to create a 4X8, 4X12, 8X8, 4X16, or even 4X20 matrix. Connections to the matrix option are made via a removable terminal block which also provides strain relief for the wires.

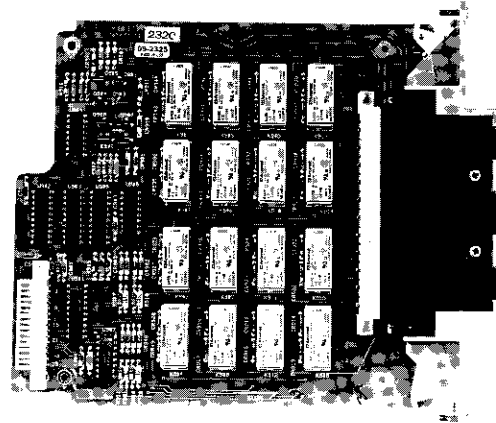

Applications

Matrix switching provides a convenient way to connect a group of test instruments to multiple points on a device or to multiple devices. The matrix offers highly flexible switching for testing multi-port devices over a frequency range of DC to 100kHz. Multiplexer options (44470A) can be used to connect the matrix switched signals to each one of several devices under test.

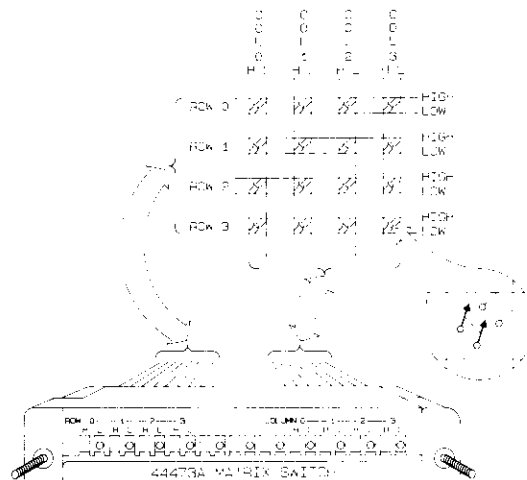

Figure 1-4. 44473A Simplified Schematic

44474A

16 Channel Digital I/O Option Option 014

Description

The 44474A consists of 16 bi-directional lines plus four handshake (interface control) lines. Each of the 16 I/O lines is TTL compatible and can act as a digital input or sense line, or as a +5 volt driven output. With an external power supply and pull-up resistors, this option can act as a digital I/O port for logic "High" levels of up to 30 volts and 125 mA. The lines can be programmed for "positive" or "negative" logic (high true or low true) and share a common signal Low.

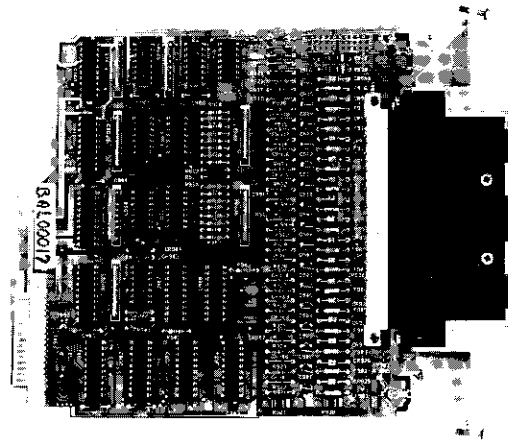

Control of the 16 I/O lines can be done on an individual, line by line basis. When controlled this way, the lines are assigned addresses of 00 to 15. For other operations, the data lines can be divided into two 8-bit ports, port 0 is data lines 00 through 07 and port 1 is data lines 08 through 15. Alternately, all 16 lines can be addressed simultaneously as a word.

Three basic modes of operation are available for I/O control or handshaking. These modes are discussed in detail in chapter 3.

- ▶ The Static mode (default) allows asynchronous data I/O. Use this mode for actuating or sensing switch contact closures to ground. (Asynchronous means that inputs and outputs are independent of any handshaking.)
- ▶ The "Strobe" modes can trigger 16 bit words to be written to or read from external circuits (such as counter and A/D converter outputs).
- ▶ The "Handshake" mode allows communication with and digital equipment by providing a 2-wire handshake plus direction line for input and output.

Applications

Scanning:

Each of the 16 I/O lines can sink up to 125 mA at 30 volts for actuation of external devices including:

- ▶ High voltage/high current relays and switches
- ▶ Programmable coaxial switches (such as -hp- 33311B/C, 8761A/B)
- ▶ Programmable attenuators (such as -hp- 355E/F, 8490 & 33320 series)

Sensing:

- ▶ Limit switch sensing
- ▶ Monitoring position of test fixture in production
- ▶ Digital communication (bidirectional)

In addition, the lines can be used to sense switch contact closures. Features such as "External Increment" and "Channel Closed" are also provided for hardware synchronization of the 3488A with other equipment in the system. Typical uses include scanning of channels synchronized to the measuring voltmeter and incrementing stored states. A detachable terminal block with strain relief is provided for wire connections.

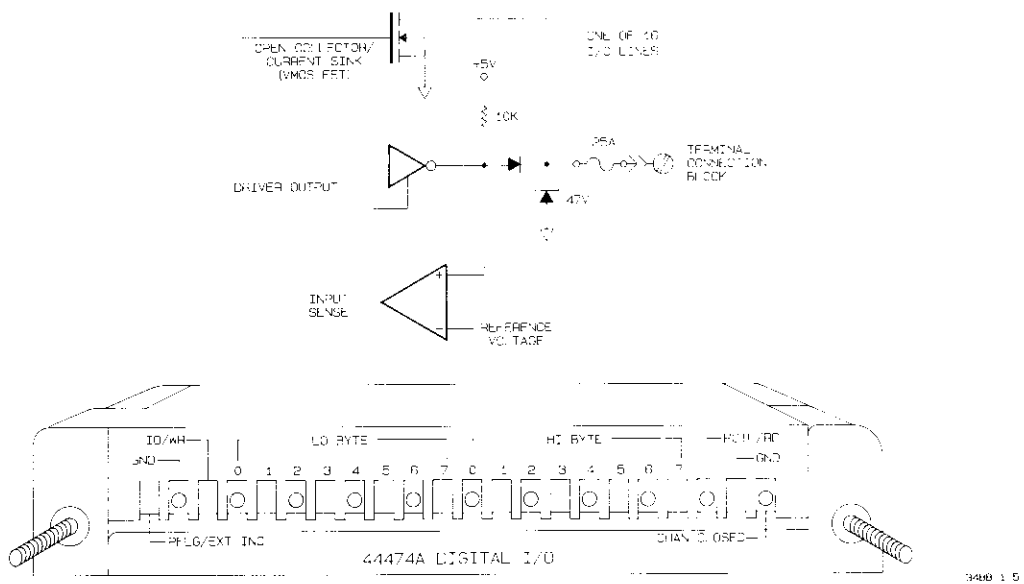

Figure 1-5. 44474A Simplified Schematic

44475A

Breadboard Option Option 015

Description

The Breadboard option provides a place for design engineers or technicians to mount custom designed circuits for use with the 3488A. Occasionally, some desired function may not be available on a standard option module. In such instances, the Breadboard option provides the ideal solution.

Components are specified (but not supplied with the breadboard card) for interfacing the breadboard to the 3488A backplane. When these components are used, the breadboard then provides 8 static input and 8 static output lines. Two commands are available to read and write to the breadboard.

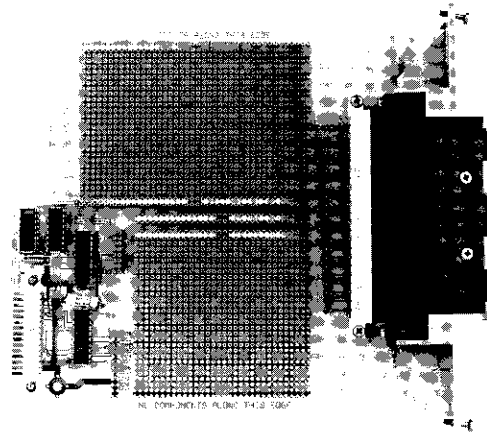

Note. At reset, the 3488A writes the value "0" to the output port.

Applications

A combination of perforated holes (0.1" centers) and bus strips (for external power supplies) is provided. No power supplies are provided from the 3488A mainframe (except for the interface circuitry) and headroom limitations preclude wire wrap sockets.

Uses for the breadboard include:

- ▶ Mounting signal conditioning circuits prior to multiplexing.
- ▶ Mounting small components such as buzzers for alarms, etc.

The following schematic shows the interface circuitry for the 3488A backplane. Refer to the 44475A option reference chapter for more information on using the Breadboard.

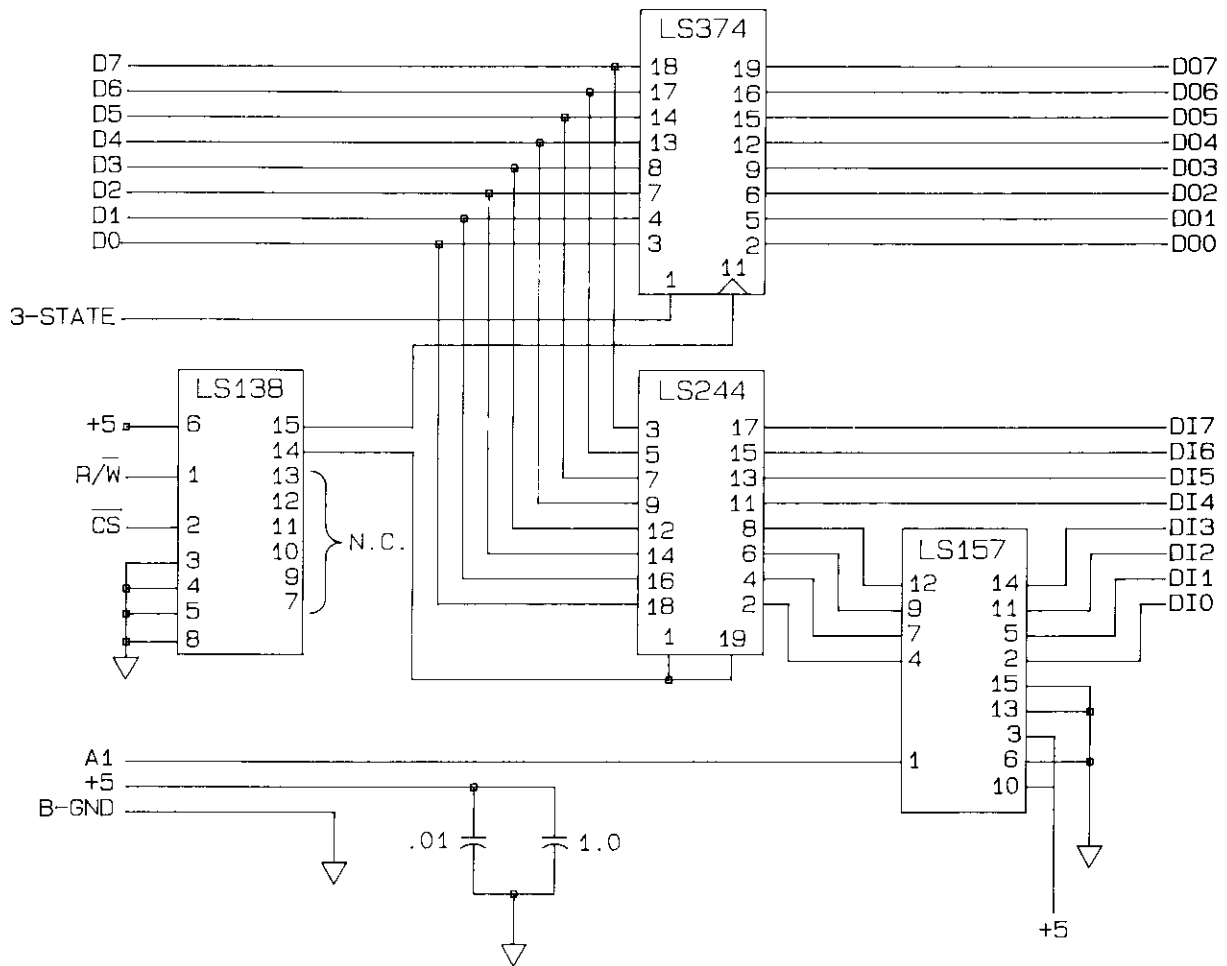

3488-1-6

Figure 1- 6. Breadboard Interface Circuitry

Chapter 2

Using the 3488A

Introduction

In Chapter 1 we learned how to turn on the 3488A and were introduced to the six option assemblies. We also discovered that the instrument is easy to operate and instructed it to show us what option assembly is installed in each of the mainframe slots. Now it is time to put the 3488A to work on your own application. Your 3488A, whether used stand alone or with a system computer, puts signal switching and device control at your disposal.



Scope

This chapter looks at operating the 3488A remotely via HP-IB as well as from the front panel. Emphasis will be placed on remote programming the instrument from a system computer. If you are not familiar with the Hewlett-Packard Interface Bus (HP-IB) or some of the terms used in this chapter, Appendix B contains a concise description of HP-IB.

The descriptions used in this chapter are written in general terms to optimize the flow of information regardless of the computer you are using. This means that both the novice and experienced programmer will be operating the 3488A productively with minimum instruction time. Many example programs are provided to enhance the discussion. All of these example programs are given in an enhanced BASIC (Beginners All-purpose Symbolic Instruction Code) programming language such as the -hp- Series 200 or Series 80 desktop computers use.

Note on Remote HP-IB Programming

If you are interested in controlling the 3488A only from the front panel, you may skip this section. It is important to understand the following information for remote programming regardless of the type of computer used.

Do This	
Press:	The 3488A will display its HP-IB address in the form: ADDRESS: XX. The factory preset address is 09.
	

Each instrument you connect to the HP-IB interface has a unique address assigned to it. The address provides a method for the system computer to select individual instruments for sending data to or receiving information from. In upcoming programming examples, we will use the statement OUTPUT 709. The word OUTPUT is a statement specific to certain -hp- computers for moving data out of the computer. The number 709 refers to the computers interface select code (isc), which is 7, and the 3488A HP-IB address which is 09. Only one instrument connected to the interface can have the address 09. If you need to change the address of the 3488A, refer to the HP-IB Address section in Chapter 5 of this manual. All examples in this manual will have the 3488A at address 09.

The following diagram shows how commands are sent to the 3488A.

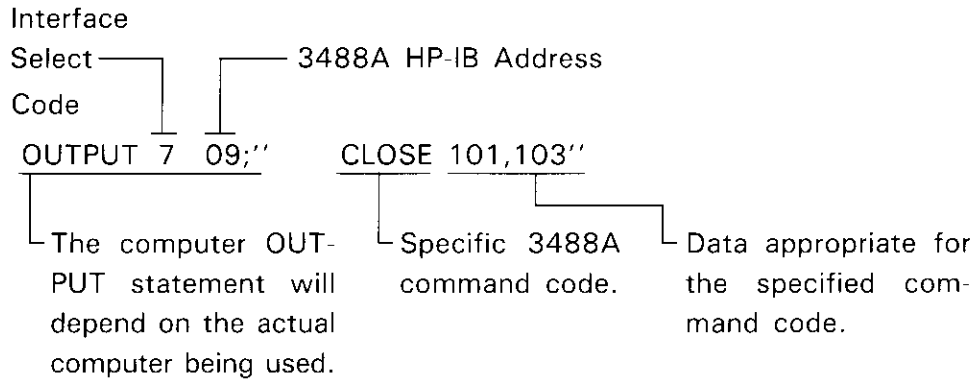

Almost all of the 3488A command codes require some type of information following it. This information is simply called data. At the end of Chapter 3 are several blue pages that describe all of the command codes the 3488A responds to and the types of data required for each code.

Trying a Command

Operation of the 3488A, whether remotely from the system computer or from its front panel, is simple and straightforward. In fact, almost any command that can be executed from the 3488A front panel can be done remotely just by duplicating the front panel activities.

To illustrate this, press the 3488A TEST key. We saw in Chapter 1 that when you do this, the 3488A goes into its Self Test mode. First, it displays its Model number, then a "starburst" pattern, and finally the message "SELF TEST OK" (or if any have failed the appropriate message is displayed).

How can we do the same thing from the system computer? It's simple, just send the message "TEST" to the 3488A. If you have an -hp- Series 200 or Series 80 desktop computer,* execute the following command exactly as shown:

```
OUTPUT 709; "TEST"                                [EXECUTE]
                                                    (on the Series 80,
                                                    press [END LINE])
```

Note that whether the TEST key is pressed on the front panel, or the message TEST is sent from the system computer, the 3488A executes its internal test. The only observable difference is the instrument does not display its model number or the starburst pattern when TEST is executed from the computer. The 3488A will display the SELF TEST OK message.

Later in this chapter we will learn to read back the results of the Self Test to the system computer. Remember, virtually any command you can execute from the 3488A front panel can be duplicated on the system computer and sent to the 3488A.

* If you don't have a Series 80 or Series 200 computer, read through this section anyway as it provides a basis for later discussions. Be sure to read through the I/O Programming manual for your computer to find out how to send command messages.

Channel and Slot Definition

Before we look further at operating the 3488A, we need to define the word 'channel'. A channel refers to an individual relay on an option assembly (or individual bits on the 44474A Digital I/O option). Therefore, when we speak of closing a channel, we are referring to closing a specified relay (or bit). Channel numbers are always two digit numbers.

Channel addresses, on the other hand, are determined by which slot a particular option assembly is installed in. The Channel Address is a three digit number where the first digit specifies the slot (1-5) and the last two digits are the channel number. For example, channel address 102 specifies slot 1, channel number 02.

The following chart shows the two digit channel numbering sequence for the different option assemblies. Refer to the simplified schematics in Chapter 1 if necessary.

Option Module	Channel Numbering Sequence
44470A, 10 Channel Multiplexer	00, 01, 02, 03 ... 08, 09
44471A, 10 Channel General Purpose Switch	00, 01, 02, 03 ... 08, 09
44472A, VHF Switch	Group 0: 00, 01, 02, 03 Group 1: 10, 11, 12, 13
44473A Matrix Switch	Row: 0, 1, 2, 3 Column: 0, 1, 2, 3 Specify the channel number in Row-Column format. i.e., channel number 12 means row 1, channel 2.
44474A Digital I/O Assembly	Individual Bits: 00, 01, 02, 03, ...15 (The 44474A has other modes where 8-bit bytes or 16-bit words can be specified. These modes are discussed in detail in Chapter 3.)

How to Close/Open a Channel

Regardless of the type of option assembly you are using, CLOSE and OPEN commands can be used to control the channels. At turn-on or after reset, all channels in the 3488A are open.

The structure of the command for closing a channel is:

CLOSE (channel address)

Pressing the 'CLOSE' key on the 3488A front panel causes the word 'CLOSE' to appear in the display. Now, enter the address of the channel you want to close. Follow this by pressing the gray 'EXECute' key. For example, if you have a 44470A, 10 channel multiplexer in slot 1 and you want to close channel 3, you would press the following sequence of keys:



CLOSE a	Slot	Channel	Execute
channel	1	3	

Closing channels remotely is just as easy. Press the CLOSE 103 keys again (do not press EXEC). Now look at the 3488A display. To close channel 103 from a system computer simply duplicate (without the cursor) what you see in the 3488A display.

OUTPUT 709; "CLOSE 103"

Anything that you can do from the 3488A front panel can also be done remotely by simply duplicating what you see in the display.

More than one channel can be closed at a time by separating the channel addresses with a comma. For example:

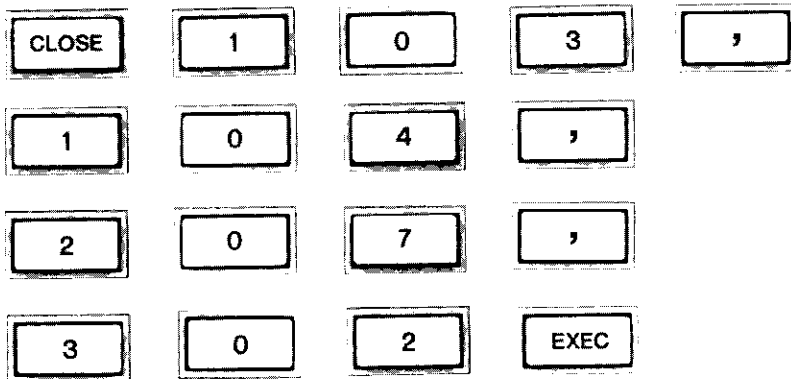

(CLOSE 103, 104, 207, 302)

Note in this last example, channels from different slots were closed with one CLOSE command.

To close multiple channels remotely, again simply duplicate the display:

OUTPUT 709; "CLOSE 103, 104, 207, 302" [EXECUTE] or
[END LINE]

When using the CLOSE command with the 44474A Digital I/O Assembly, the specified bits will be 'cleared' to a logical 0 state (low impedance). Remember also, to use CLOSE and OPEN with the Digital I/O assembly, the assembly must be in either Static Mode 1 or Mode 2 (Mode 1 is default). Refer to the DMODE command for more information.

Opening a channel is just as easy as closing one. The command structure for opening a channel is:

OPEN (channel address)

If you need to open channel 03 in slot 1, simply execute the command OPEN 103.

OUTPUT 709; "OPEN 103" [EXECUTE] or
[END LINE]

or

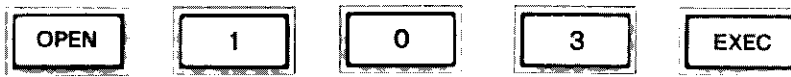

Open the Slot channel EXECute
channel 1 add. 03

More than one channel can be opened with the OPEN command just by separating the addresses with a comma.

OUTPUT 709; "OPEN 103,104,207,302"

or

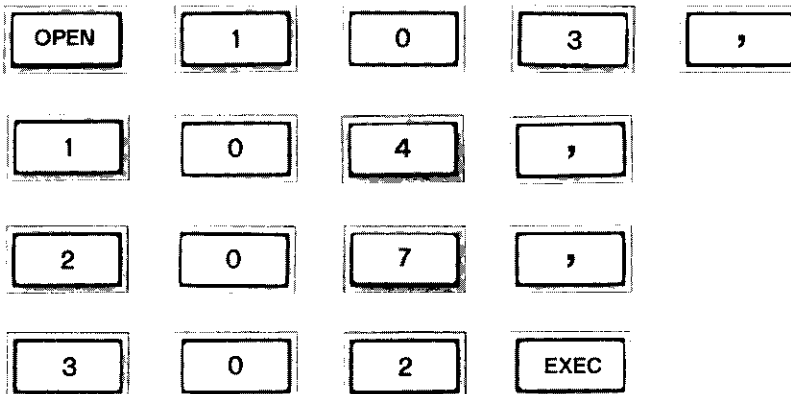

If you should try to close a channel that does not exist, an execution error will be displayed: ERR 2: EXEC. Scrolling the display to the left shows the last twelve characters up to and including the error. This provides a simple way to determine where an error occurred.



Command

CLOSE <relay address> [, <relay Address>, ...]

OPEN <relay address> [, <relay Address>, ...]

Note, < > means a mandatory item, [] is an optional item. These are not keystrokes or displayed.

How to VIEW a Channel

There are times when you will want to look at a particular channel to determine if it is open or closed. The VIEW command allows you to do this very easily. To view a channel, execute the VIEW command followed by a channel address. To acquire the response, execute the computer's ENTER* command:

OUTPUT 709; "VIEW 103"

ENTER 709; A\$

DISP A\$

The computer display will show either "CLOSED 0" OR "OPEN 1". If a simple numeric variable had been used (A instead of A\$), only the number "0" or "1" would be displayed.

To do this from the 3488A front panel, duplicate the procedure:



* If you are using an -hp- Series 200 desktop computer, remember that all variables must be used in a running program before they can be used in statements executed from the keyboard.

If the channel specified is closed, the 3488A response will be "CLOSED 0". If the channel is open, the response will be "OPEN 1". Note that in the display, the channel address precedes the response.

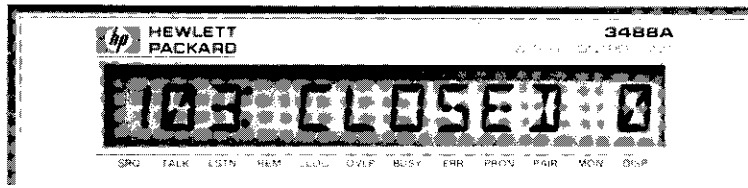

or

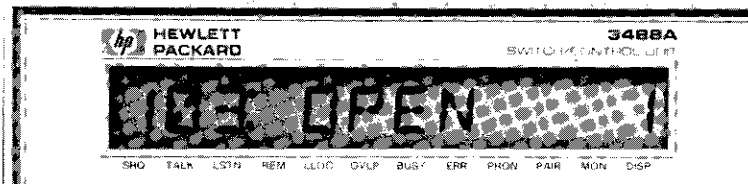

Command

VIEW (channel address)

How to Monitor an Entire Option Assembly

The VIEW command allowed viewing only one channel at a time and allowed reading the state of that relay with the system computer. For viewing all the channels on an option card, use the Card Monitor feature.

Card Monitor places the 3488A display in a mode where it is dedicated to monitoring the option assembly in a specified 3488A slot. Note that you cannot read back the monitor display to the computer. To enter the Card Monitor mode, execute CMON (acronym for Card MONitor) followed by a slot number (1-5).

OUTPUT 709; "CMON 3"

Implementing the Card Monitor mode from the keyboard is just as simple:

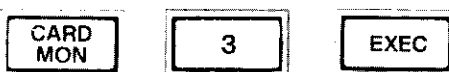

The following section describes the unique card monitor displays for each of the six options and the Monitor Tracking mode. A simplified schematic is provided for each of the options to help you visualize what the card monitor display is showing.

Monitoring a 44470A 10 Channel Multiplexer or 44471A General Purpose Relay Assembly

When using the monitor mode with either 44470A 10 Channel Multiplexer or 44471A 10 Channel General Purpose Relay options, the display will show the slot number (far left) and only those channels that are closed. The following photograph shows the format of the monitor for these two options.

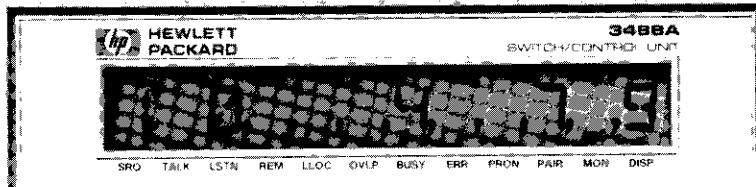

Slot 1, Channels 0, 4, 7 and 9 are closed

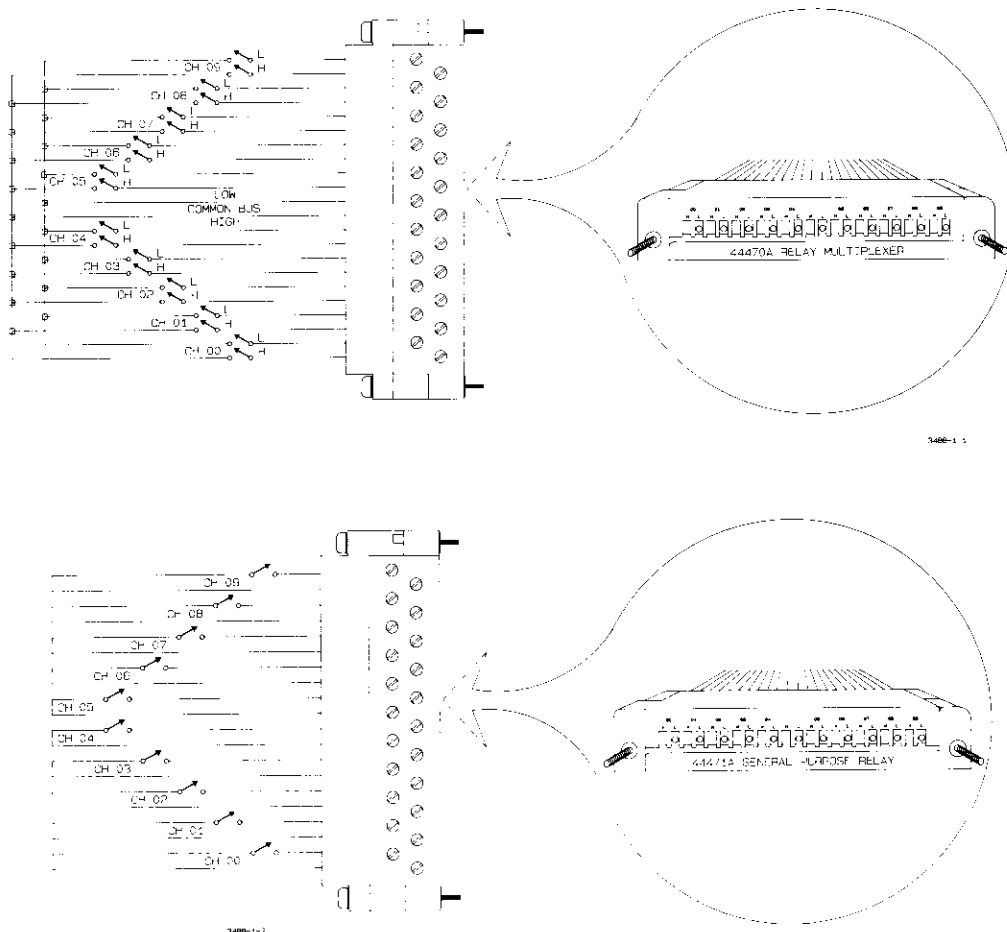
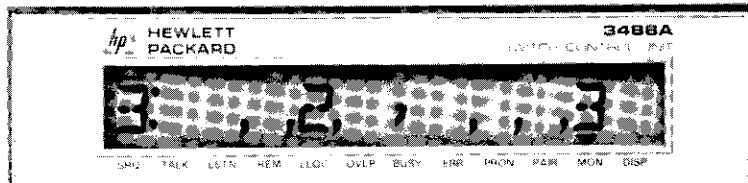

Figure 2-1. Simplified Schematic for 44470A and 44471A

Monitoring a 44472A VHF Switch

Because the 44472A assembly has two groups of 4 channel multiplexers (0 and 1), the monitor display is broken into two parts. The left half of the display monitors group 0, the right half monitors group 1. The following photograph shows the display after closing channels 302,313.



Slot 3 Group 0 has channel 2 closed
 Group 1 has channel 3 closed

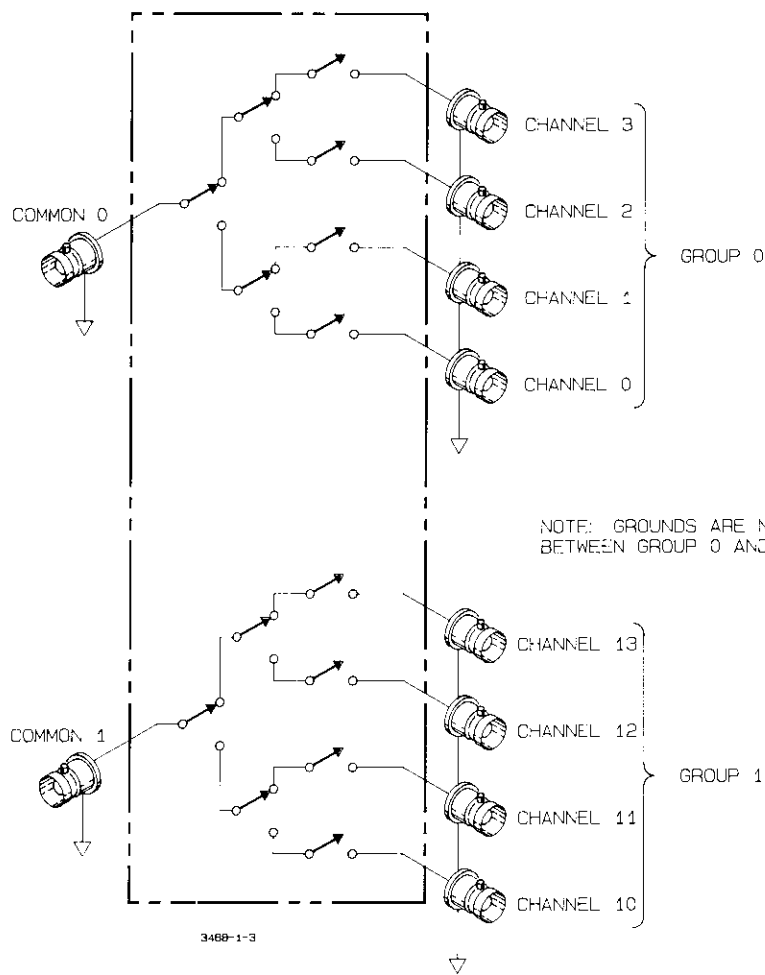
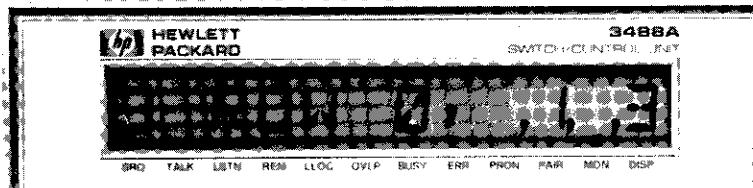

Figure 2-2. Simplified Schematic for 44472A

Monitoring a 44473A Matrix Assembly

There are two types of monitoring displays for the 44473A Matrix Assembly: monitoring ROWS and monitoring COLUMNS. A total of eight displays are possible, one for each of the four rows and four columns. When initially entering the Card Monitoring mode, the display will show which columns have a channel closed in row 0. Use the front panel arrow keys to sequence through the displays. The following displays show how the same matrix option can be monitored after executing the commands: CLOSE 301,303,323; CMON3.



Slot 3, Row 0 in Columns 1 and 3 are closed

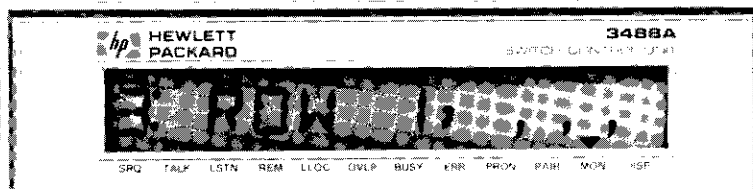

Slot 3, Row 1, nothing closed

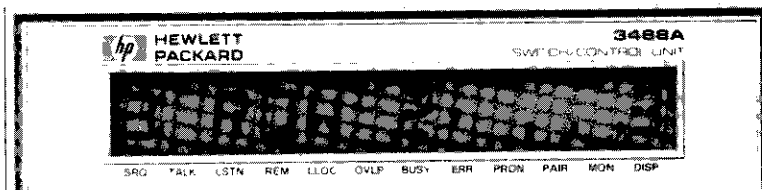

Slot 3, Row 2 in Column 3 is closed

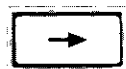
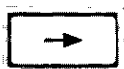

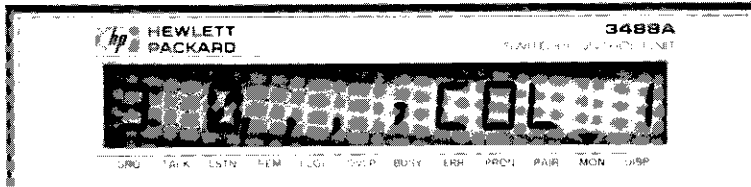

Slot 3, (Row) 0 in Column 1 is closed

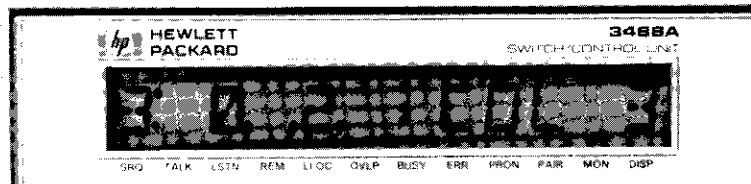
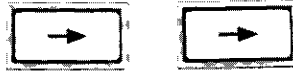

Slot 3, (Rows) 0 and 2 in Column 3 are closed

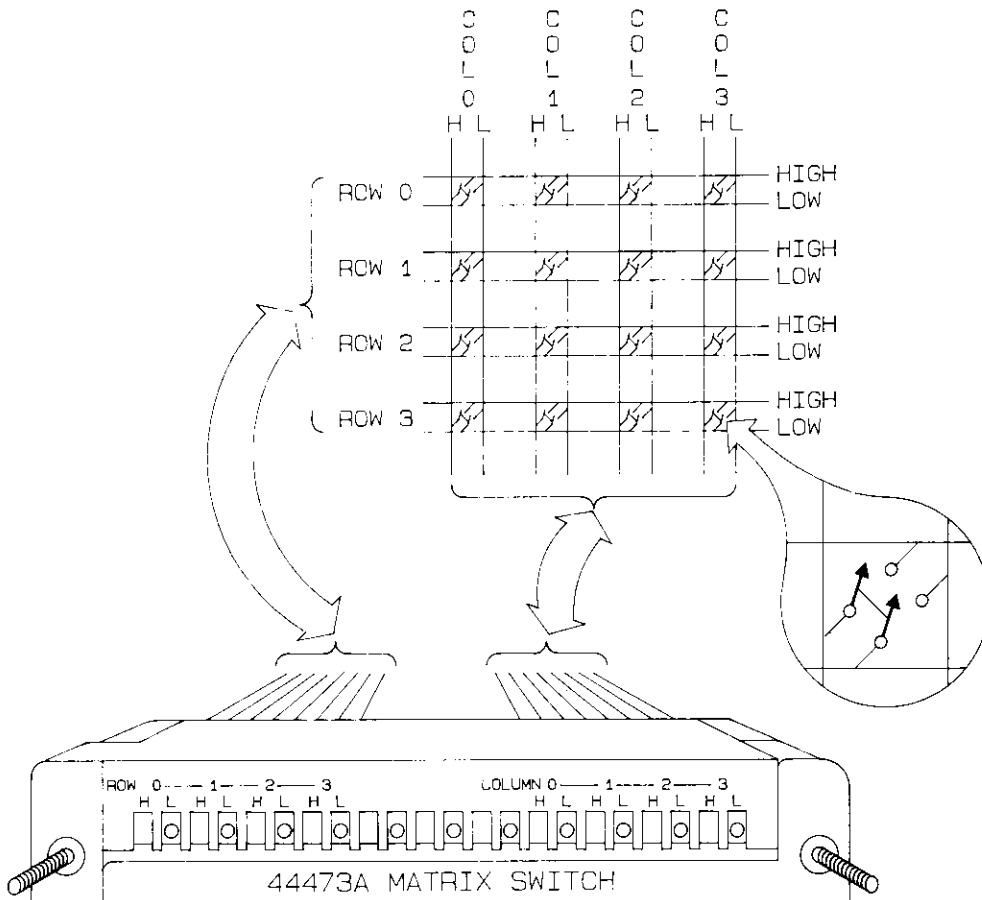

3488-1-4

Figure 2-3. 44473A Simplified Schematic

Monitoring a 44474A Digital I/O Assembly

The monitor display for the 44474A Digital I/O assembly is similar to the photograph below. The H and L represent the High order 8-bit byte and Low order 8-bit byte, respectively. A trailing decimal point for either byte indicates that the last operation on that byte was a write (or close) command (i.e., it is an output byte). If the decimal point does not appear, the byte was last read from (i.e., it is an input byte).

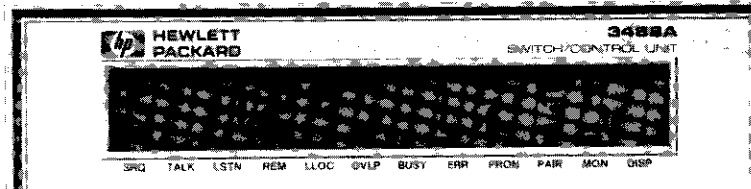

When initially entering the monitor mode, the display will indicate a decimal value. If the byte is an input byte (no trailing decimal point) the value is equal to the sum of the values of the bits that are high (logic 1, +5v). If the byte is an output byte, the value is equal to the sum of the values of the bits that are open (logic 1, high impedance). Refer to the following chart for a description of the bit values.

Bit Number:	15	14	13	12	11	10	9	8	7	6	5	4	3	2	1	0
8-bit byte value	128	64	32	16	8	4	2	1	128	64	32	16	8	4	2	1
	High order 8-bit Byte								Low order 8-bit Byte							

Execute the commands:

CLOSE 500, 501, 502, 503, 505, 506, 507; CMON 5

The display will show:

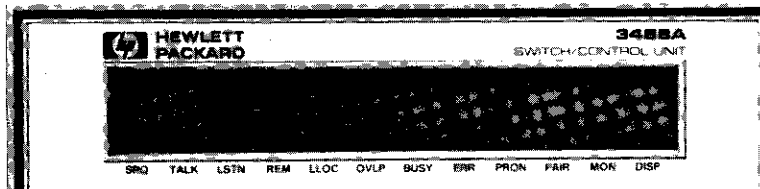

This indicates that the high byte (H) is operated as an input byte (default), and the low byte (L) is an output byte (indicated by the decimal point). Since only channel 4 was left open in the low byte, the displayed value is 16.

Pressing the front panel arrow keys causes the display to toggle between a decimal display and a hexadecimal display.

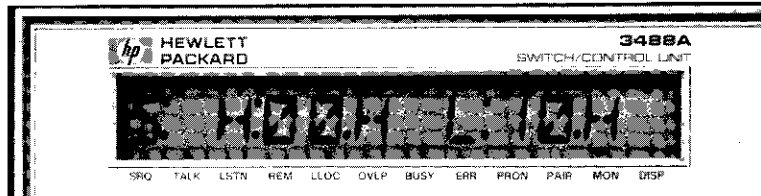

Here, the last H after each byte emphasizes the hexadecimal display.

If the last command sent to the 44474A option put it into the 16 bit word mode (port 2, see DWRITE in Chapter 3), the Monitor would be displayed as a 16 bit word:

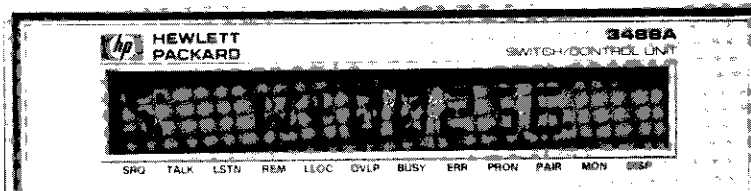

A positive number indicates that the value displayed is the sum of the bit values that are clear (logical true). A negative number indicates the displayed number is the 2's complement of the sum of the bit values. This is valid only for the default polarity. If the polarity has been changed by the DMODE command, the displayed value will still be in 2's complement format. Chapter 3 discusses the 16 bit mode in detail.

Pressing either of the arrow keys changes the display to hexadecimal format:

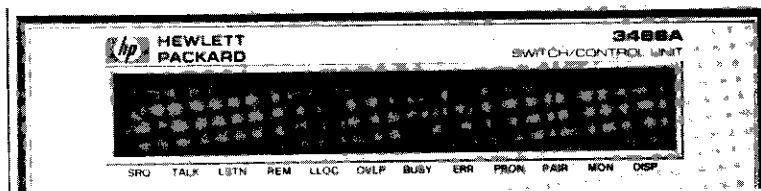

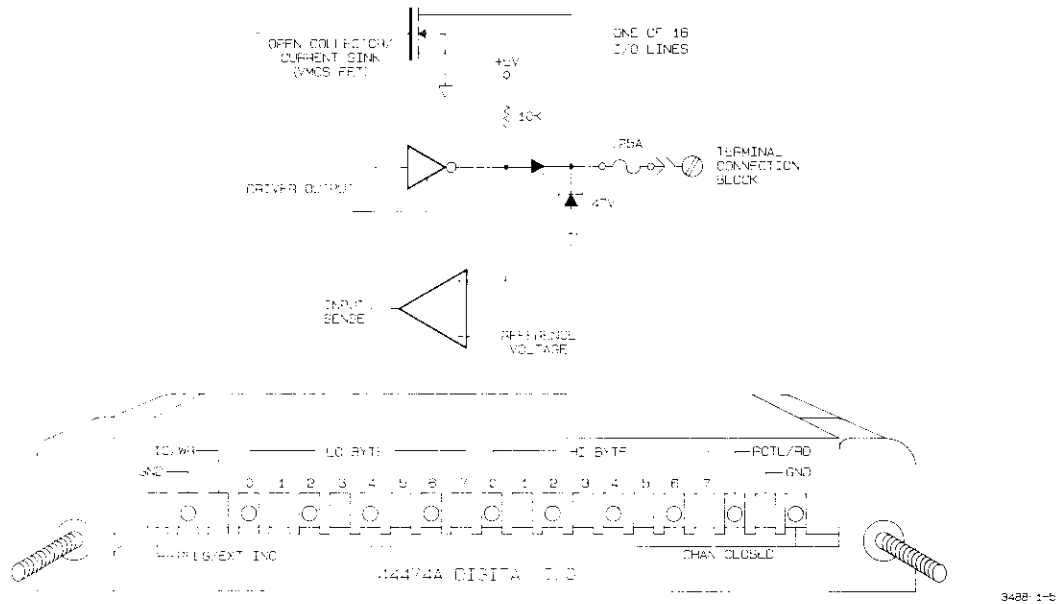

Figure 2-4. 44474A Simplified Schematic

Monitor Tracking

A second form of the Monitor mode is called Monitor Tracking. Monitor tracking permits the display to monitor the 3488A slot where the last operation (channel closure or open) was performed. To enter the Monitor tracking mode, execute CMON with a negative slot number, i.e., CMON-2. The slot number specified will be the first slot monitored. Then if you perform some other operation, such as close a channel in slot 5, the display will track the operation and begin monitoring slot 5.



Command

- CMON n where n is the slot number of the card to be monitored.
- CMON-n Monitor tracking mode starting with slot n.
- CMON0 Exit card monitor mode.

Resetting Individual Option Assemblies

The orange RESET key on the front panel of the 3488A is used to reset the entire instrument. There may be times though when you need to reset only one option assembly to its power on state. That is the function of the CARD RESET command.

To reset a particular option from the system computer, execute the CRESET command with a specific slot number:

OUTPUT 709; "CRESET 2" (Resets the option in slot 2)

More than one option can be reset by separating the slot numbers with commas.

OUTPUT 709; "CRESET 1, 3" (Resets options in slots 1 and 3)

Option assemblies 44470A, 44471A, 44472A, and 44473A are reset to all channels open. For the 44470A, 44471A, and 44473A options only, the 3488A checks sense lines after the CRESET command to verify that all relays actually did open. If one or more relays remains closed, ERROR 8 is set. The 44474A Digital I/O assembly is reset to its static mode, 16 bit input configuration. The 44475A Breadboard Card is reset to all of its output lines low.



Command

CRESET (slot number)[,(slot number), ...]

Self Test

The Self Test feature of the 3488A provides you with a method of verifying proper instrument operation. When the front panel TEST key is pressed, or the command TEST is sent from the computer, the 3488A performs tests on its control circuitry (ROM, RAM, timer, etc.). The self test can be executed at any time because the option assemblies will not change state during the test.

Do This:

OUTPUT 709; "TEST"
ENTER 709; A
DISP A

or



Either of these two methods will initiate the functional tests of the internal control circuitry. If the test is initiated remotely from the computer, only the internal tests are performed. If the self test is initiated from the front panel, the test starts by displaying the model number: HP3488A. Self test then proceeds to turn on every segment in the display (except top dot in the colon between characters). The internal tests are then performed. When all the tests have passed, the 3488A displays: SELF TEST OK. If a failure is found, the message: FAILED nn is displayed, where nn is the sum of the values of all the tests that failed. Test results may also be read over the HP-IB interface. In this case, only the number nn is returned (0 is returned for no failures).

Table 2-1. Self Test Errors

Error Number	Description
1	The internal storage RAM (Random Access Memory) has failed its self test.
2	ROM (Read Only memory) has failed.
4	The timer, used for delay timing, etc., has failed.
8	A limited self test on the HP IB controller I.C. has failed.

For all failures, refer to the 3488A Mainframe service manual.



Command

TEST

Using the Display

Three commands that can be executed from the system computer but not directly from the 3488A front panel involve the display. The first command we will look at enables you to write messages up to 127 characters long to the 3488A display. Execute the following command exactly as shown, substituting your real name after the DISP mnemonic.

```
OUTPUT 709; "DISP your name"           [EXECUTE] or  
                                         [END LINE]
```

Your message can contain any of the 64 ASCII characters with decimal values from 32 to 95 except the # sign and colon (:). All other characters will either cause an error (such as # or :) or will be ignored. Character strings in excess of 127 characters will be truncated after the 127th character. Quotation marks (") are ignored. Lower case alphabet characters are displayed as upper case.

The displayed message will remain in the display until a RESET, LOCAL, CMON, DON, DOFF or another DISP command is executed.

The display can also be turned off. Executing the command

```
OUTPUT 709; "DOFF"
```

causes the 3488A to fill the display with hyphens and then ignore the display. The display is not updated after this although it takes approximately 10 minutes for the display to actually go blank. Turning the display off allows the 3488A to process commands quicker because it does not update the display. Normal rate of update is 5 times per second.

Turn the display back on by executing:

```
OUTPUT 709; "DON"
```

or by pressing the LOCAL key on the front panel.

Handling Errors

Perhaps you have tried to execute a command on the 3488A, but it only beeps and displays a cryptic error message. What do you do now?

The 3488A has the ability to show you where in the executed command an error was detected. For example, attempt to close channel 703. This can be done remotely from the computer or from the front panel. The 3488A display would show the following message:

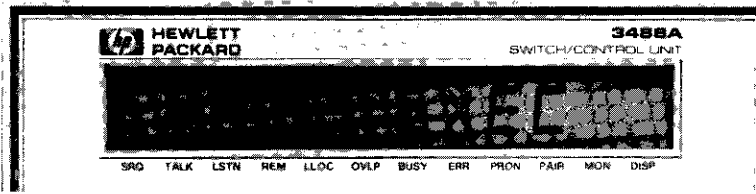

Now, press (and hold) the left arrow key. The last character in the display is the character that caused the error:

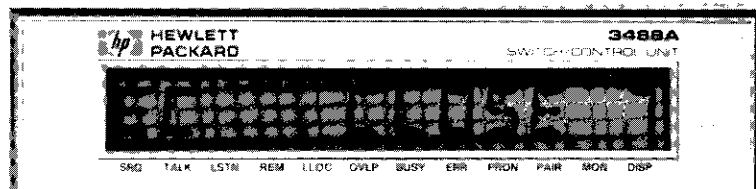

In this case, there is no slot 7. Therefore, that is the invalid character.

When an error occurs, a message is displayed and the error annunciator is turned on. To clear the annunciator, the Error Register must be read.

The possible error messages are:

Errors	Description
ERR 1: SYNTAX	An unknown command was sent to the 3488A. For example, CLSE instead of CLOSE.
ERR 2: EXEC	The command mnemonic was correct, but for one or more of the following reasons, the command cannot be executed. a. Channel number out of range. b. Card type mismatch (i.e., execute DMODE on a Multiplexer, etc.) c. Attempt to recall a non-existent stored state, scan list or assembly program.
ERR 4: TRIG	The External Increment trigger pulse is occurring too fast. The 3488A cannot close channels as fast as the trigger pulse is occurring.
ERR 8: LOGIC	A relay bit that was instructed to close or open did not change state.
ERR 16: POWER	The ac power line is out of the allowable voltage range.

Error messages appear in the display until the error is cleared or the display is written over by another command. When remote programming, it is possible to miss an error message. You would know that an error occurred by the error annunciator in the display. The Error Register can be used to determine the nature of the error in such a case.

Reading the Error Register

The front panel ERROR REG key or the ERROR command can be used to read the value of the 3488A's error register. This causes the instrument to display and send (to the system computer) a decimal value which is the sum of the values of the possible error conditions. The error register is cleared when it is read or when the 3488A is reset.

```
OUTPUT 709; "ERROR"  
ENTER 709; A  
DISP A
```

In addition, the 3488A can be programmed to halt all activities when an error occurs. Normally, after an error occurs, the 3488A will continue to accept commands. It is possible, as mentioned earlier, to miss an error message. The Error Halt (EHALT) mode, when enabled, will cause ALL HP-IB activity to cease. If EHALT is implemented, the computer should be programmed to timeout and reset the interface when HP-IB instruments do not respond. The 3488A can then be reset with an HP-IB CLEAR command (CLEAR 709). Also, pressing the front panel LOCAL key will return control to the 3488A.



Command

ERROR	Read the Error Register
EHALT 0	Turn off the Error Halt mode
EHALT 1	Turn on Error Halt mode

The STATUS Command

The current state of the 3488A is monitored in a Status Byte. This Status Byte can be read, either remotely from the system computer or from the front panel to determine the current value. The decimal value displayed (or returned) is equal to the sum of the values in the Status Byte that are set:

Status Byte Bit Number	Weighted Value	Description
0	1	This bit will be set when a scan list has sequenced through to the last item in the list.
1	2	Bit 1 will be set when the 3488A has been asked for information and the data is available.
2	4	Power-on SRQ occurred. Note that this feature is switch selected on the back panel of the 3488A.
3	8	Front Panel SRQ key has been pressed.
4	16	The 3488A is ready to accept and process instructions (not busy).
5	32	An Error condition has occurred, refer to the section on handling errors.
6	64	The 3488A is setting the SRQ line in the HP-IB interface. See Chapter 4 for information and examples on remote interrupt programming.
7	128	Unused (always 0)

Bit 7	Bit 6	Bit 5	Bit 4	Bit 3	Bit 2	Bit 1	Bit 0
Unused	Set: SRQ interrupt	Set: ERROR condition occurred	Set: 3488A is ready for new instruction	Set: Front Panel SRQ key has been pressed.	Set: Power-On SRQ switch set and power-on occurred	Set: Requested information is available.	Set: End of Scan List.
Always 0	Cleared: Condition causing SRQ is cleared or HP-IB SPOLL command or 3488A is reset.	Cleared: Error register is read or 3488A is reset.	Cleared: 3488A is busy executing previous instruction	Cleared: STATUS command or 3488A reset.	Cleared: STATUS command or 3488A is reset	Cleared: STATUS command, reading the data, or resetting the 3488A. Note, STATUS deletes old information.	Cleared: STATUS command.

Figure 2-5. Status Byte

Bits 0, 1, 2 and 3 will be cleared after the Status Byte is read by the STATUS command. The Error bit, bit 5, will be set until the error register is read or the 3488A is reset. Bit 2 will be set when the rear panel Power-on SRQ switch is set (switch in up position) and the 3488A is turned on.

Bit 1 will be cleared by either reading the data that is available, requesting new data, or resetting the 3488A. Note that because bit 1 is cleared when new data is requested, executing the STATUS command remotely (requesting the value of the Status Byte) deletes the data that was available.

Similarly, bit 4 will be clear while the 3488A is busy executing an instruction. Therefore, bit 4 will always appear clear in response to the STATUS command. The SPOLL command (see Chapter 4) must be used to properly detect when the 3488A is not busy (bit 4) or when output data is available (bit 1).

Bit 6 is set when there is any one-to-one correspondence between bits set in the SRQ mask (see Chapter 4, Require Service) and bits set in the Status Byte. Bit 6 will only be cleared when the condition causing it to be set is cleared or by the HP-IB SPOLL message (see Chapter 4, Serial Poll). No other bits are cleared by SPOLL.

Do This:

OUTPUT 709; "STATUS"
ENTER 709; Z
DISP Z

"Z" will have a value of 0.

or



The display will show: STATUS: 000

Now, press the front panel SRQ key:



Again, execute the STATUS command.

OUTPUT 709; "STATUS"
ENTER 709; Z
DISP Z

"Z" will have a value of 8 which is the value for the front or panel SRQ key.

or



The display will show: STATUS: 008

As a second example, attempt to close an invalid channel:

```
OUTPUT 709; "CLOSE 7"  
OUTPUT 709; "STATUS"  
ENTER 709; Z  
DISP Z
```

"Z" will have a value of 32 which indicates an error condition.

or

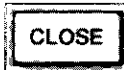

The display will show: STATUS: 032

Notes

1. The value returned is the sum of all condition values that are true.
2. Bit 6 is set only if a condition is true and the SRQ Mask has been set for that bit. See Chapter 4.
3. The Status Register is cleared at Reset.
4. Bit 2



Command

STATUS

Using the Built-in Quick Reference Guide

After becoming familiar with the 3488A, you will use this operator's manual less frequently. The structure of the various commands is straightforward. However, if you should forget the command structure, and not have this manual present to help, it is comforting to know that the 3488A has a Quick Reference Guide built into it. The Quick Reference Guide is available only from the front panel with the SYNTAX key.

To use the Quick Reference Guide, press the SYNTAX key followed by a command key. For example, to find out the command structure for closing a relay, press:



The display will show the following message (scroll the display to see all of it):

CLOSE <ADDRESS>[,<ADDRESS>]...; SEE REFERENCE 5 FOR ADDRESS

This means that to close a channel, use the command code CLOSE. This is to be followed by an address. But what is an address? And what are the brackets (<>, []) for?

The Quick Reference Guide says to SEE REFERENCE 5 FOR ADDRESS. Reference 5 contains a definition of an address. Press:

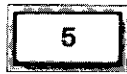

The display will show the following definition for ADDRESS:

ADDRESS: A THREE DIGIT NUMBER WITH THE FIRST NUMBER BEING SLOT AND THE NEXT TWO DIGITS BEING EITHER A RELAY NUMBER OR A BIT NUMBER

The numeric keypad contains rules and definitions. For example, to define the brackets <>, look at reference 0:



<>: PARAMETRIC ITEMS

Which means anything enclosed in this type of bracket is mandatory.













[]: OPTIONAL ITEMS





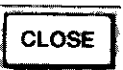

Which means anything enclosed in this type of bracket is optional.

Getting back to closing a channel, we see that the command mnemonic is the word CLOSE. This is to be followed by a mandatory three digit channel address. Optional channel addresses can also be included by separating the addresses with a comma.



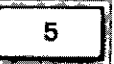

In general, the command and control keys provide instruction information. The numeric keys provide definitions. There are some keys that do not have a remote programming command code associated with them. These keys are shown as NA (Not Applicable). The following list shows the possible displays for each of the keys on the front panel.

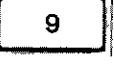
Key	Display	For more information see page:
	RESET	6
	NA; SEE REFERENCE 3	
	NA; SEE REFERENCE 3	
	NA; SEE REFERENCE 3	
	NA; SEE REFERENCE 3	82
	NA; SEE REFERENCE 3	100
	STATUS; RETURNS WEIGHTED SUM OF 1:END OF SCAN, 2:OUTPUT AVAILABLE, 4:POWER ON, 8:FRONT PANEL SRQ, 16:READY, 32:ERROR, 64:RQS	42
	MASK[<#>]; #: WEIGHTED SUM OF 1:END OF SCAN, 2:OUTPUT AVAILABLE, 4:POWER ON, 8:FRONT PANEL SRQ, 16:READY, 32:ERROR,	85
	NA; SEE REFERENCE 3	84
	CLOSE <ADDRESS>[,<ADDRESS>]...; SEE REFERENCE 5 FOR ADDRESS	25
	OPEN <ADDRESS>[,<ADDRESS>]...; SEE REFERENCE 5 FOR ADDRESS	25
	VIEW <ADDRESS>; SEE REFERENCE 5 FOR ADDRESS	27

Key	Display	For more information see page:
CARD MON	CMON [-]<0/SLOT>; NEGATIVE SIGN SELECTS TRACKING MONITOR. TO EXIT, USE A PARAMETER OF 0. SEE REFERENCES 2 AND 4.	28
CARD RESET	CRESET <SLOT>[,<SLOT>]...; SEE REFERENCE 4 FOR SLOT	36
CARD TYPE	CTYPE <SLOT>; SEE REFERENCE 4 FOR SLOT	8
STORE	STORE <SETUP>; SEE REFERENCE 7 FOR SETUP	51
RECALL	RECALL <SETUP>; SEE REFERENCE 7 FOR SETUP	51
SCAN LIST	SLIST <ADDRESS/SETUP> [<,-> <ADDRESS/SETUP> ...]; USE NEGATIVE SIGN TO SCAN A CONSECUTIVE LIST. SEE REFERENCES 2, 5, AND 7.	53
CHAN	CHAN [<ADDRESS>]; SEE REFERENCE 5 FOR ADDRESS	55
CARD PAIR	CPAIR [<SLOT>,<SLOT>]; SEE REFERENCE 5 FOR ADDRESS	58
STEP	STEP	55
WRITE	DWRITE <SLOT> <0> <PORT>, <DATA> [, <DATA>]...; SEE REFERENCES 4 AND 6	216
READ	DREAD <SLOT> <0> <PORT> [, <NUMBER OF READINGS>]; SEE REFERENCES 4 AND 6	218
MODE	DMODE <SLOT> [, <HANDSHAKE MODE>] [, <POLARITY>] [, <EXTERNAL INCREMENT>]; SEE REFERENCES 4, 8 AND 9	220

Key	Display	For more information see page:
	DELAY [<TIME IN MILLISECONDS>]	59
	< >: PARAMETRIC ITEMS	
	[]: OPTIONAL ITEMS	
	X/Y: USE EITHER X OR Y	
	NA: NOT APPLICABLE	
	SLOT: A NUMBER FROM 1 TO 5 THAT SELECTS ONE OF THE 3488A SLOTS	24
	ADDRESS: A THREE DIGIT NUMBER WITH THE FIRST NUMBER BEING SLOT AND THE NEXT TWO DIGITS BEING EITHER A RELAY OR A BIT NUMBER	24
	PORT: USE 0 TO SELECT LOWER BYTE, 1 TO SELECT UPPER BYTE AND 2 TO SELECT THE WORD.	209
	SETUP: USE ANY NUMBER BETWEEN 1 AND 40.	51
	THE HANDSHAKE MODES ARE 1:STATIC R OR W, 2:STATIC R & W, 3:R/W & STROBE, 4:RD & WR, 5:FULL HANDSHAKE.	220
	TO INVERT LOGIC, USE A WEIGHTED SUM OF 1:LOW BYTE, 2:HIGH BYTE, 4: PCTL, 8:PFLG, 16:I/O DIRECTION. SET E.I. TO 1 TO ENABLE.	225
	NA; SEE REFERENCE 3.	

For more
information
see page:

Key	Display	
	NA; SEE REFERENCE 3.	
	NA; SEE REFERENCE 3	
	ERROR; RETURNS WEIGHTED SUM OF 1:SYNTAX, 2:EXECUTION, 4:HARDWARE TRIG- GER TOO FAST, 8:LOGIC, 16:POWER SUPPLY.	39
	NA; SEE REFERENCE 3	
	TEST; RETURNS WEIGHTED SUM OF 1:RAM FAILURE, 2:ROM FAILURE, 4:TIMER FAILURE, 8:I/O FAILURE	36

Chapter 3

More Functions and Features

Introduction

So far you have learned the rudiments of closing and opening channels. But the 3488A opens up a wider range of possibilities with channel scanning, store and recall of channel setups, pairing cards together, and more. This chapter is devoted to helping you get the most efficient use out of your 3488A.

This chapter is broken down into two main sections for easy reference. The first of these sections shows you how to store up to 40 channel setups and recall them when needed. Scanning through a list of channels is discussed in the second section. You will also learn to pair options together for special measurement needs such as 4-wire ohms.

Storing and Recalling Channel Configurations

Often you may find it convenient to have a particular, repeatable channel configuration that encompasses several option assemblies. Opening and closing each individual channel each time you want the configuration becomes time consuming and cumbersome. The STORE and RECALL commands make this task very easy.

To store a channel configuration, simply set the channels to the configuration you need. Now, STORE the configuration in any of 40 registers (numbered 1 to 40). For example, to store a configuration in register 28, press:



Only the states of relays and digital I/O options in either static mode 1 or 2 will be stored. Digital I/O options that are not in the static mode are ignored. The current state of the 3488A will not be changed by executing the command. Also, display monitor mode, scan list, etc. are not stored.

Do This

Lets try a simple experiment to see how configurations are stored. First, press the front panel RESET key. Now close several channels on different option assemblies. For example:

CLOSE 101,103,106,204,302,206,410

Monitor one of the slots to make sure the channels are closed:

CMON 1

Store this setup in register 28

STORE 28

Now, at any time you want to reassert that same channel configuration, simply recall the register where the configuration was stored.



When a stored state is recalled, the 3488A reconfigures itself one slot at a time, beginning with slot 1, channel 00. Only relays and static digital output lines are stored and recalled.

Now, let's recall the configuration we stored earlier. First though, reset the 3488A by pressing the front panel RESET key. All the channels should open.

Now, recall the configuration:

RECALL 28

Monitor each of the slots and you will see that the channels we closed earlier are now closed again.

NOTE. When recalling stored setups, the 3488A begins with slot 1, channel 0 and sequences through each channel before proceeding to slot 2. After slot 2 is configured, then comes slot 3, and so on until slot 5 is configured. Configuring is done by either opening or closing appropriate channels.

When recalling a register, if no state was stored in the selected register, the 3488A will show an Error 2. If properly enabled, the 3488 will generate an SRQ interrupt

to the system computer (See Chapter 4). In this event, the 3488A will remain in its previous configuration.

Scanning Through a List of Channels

Scanning allows you to sequence through a list of relays, digital I/O lines, or stored setups. The scan list is made up of 85 channels (or setups) separated by commas. Contiguous channels may be specified by entering the first and last numbers separated with a hyphen.

The Scan List (SLIST) command is used to specify the channel sequence. A typical scan list command might look like:

SLIST 104,205,300-309,403

In this case, the scanning would start with channel 104. Then channel 205, followed by channel 300, then 301, 302, ... 308, 309 and finally, channel 403. Each closed channel is opened before the next channel closes (break-before-make). Channels may be scanned in any sequence. For example, if the sequence were specified as 309-300, then channel 309 would be closed first, followed by 308, 307, ... 302, 301, and finally 300. Scanning beyond the last channel in the list causes a wraparound to the first channel.

Before going further, let's look at a simple example. In this example, a 44470A Multiplexer card is installed in slot 1 of the 3488A.

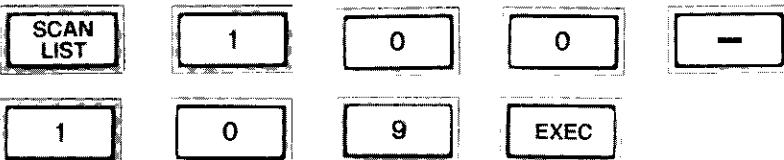
Do This: 

We now have a scan list composed of channels 100 through 109 specified. Now, let's monitor slot 1.



The display should look like:

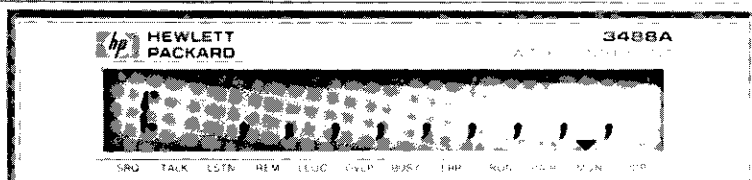

Now, step through the scan list by repeatedly pressing the STEP key. The first time you press it, channel 100 will close (0 in the monitor display). The next time STEP is pressed, channel 100 opens and channel 101 closes. Press the STEP key several times and watch the scan list wraparound to channel 100 again.

Scan lists can include any or all option assemblies except the 44475A Breadboard. A simple scan list to include all channels on the 44473A Matrix option would be: SLIST 400-433. This scan list will start with row 0, column 0 and step through column 1, column 2, and column 3; then it will move to Row 1, column 0, column 1, etc. Likewise, a scan list for the 44472A VHF Switch would be: SLIST 400-413. This scan list would step through each channel in group 0 and then group 1.

Remember that any command you can execute from the front panel can also be executed remotely from the system computer. The following program shows how the simple exercise we did earlier can be done from the computer.

```
10 OUTPUT 709 : "SLIST 100-109 :  
   CMON 1"  
20 FOR I=1 TO 20  
30 OUTPUT 709 : "STEP"  
40 WAIT 500  
50 NEXT I  
60 END
```

The WAIT statement in line 40 is only to allow you to watch the 3488A Monitor display. Line 40 can be eliminated but the 3488A display, which is updated 5 times per second, will not catch all the channel closures. Line 30 can be replaced by the HP-IB TRIGGER command (i.e., 30 TRIGGER 715). This can provide slightly faster operation.

Another feature of the scan list is a stop channel. Including the channel number "0" in the scan list, causes the previous channel to open but no channels to close. As an example, look at the scan list 100-104,0,105-109,0. After stepping to channel 104, the next STEP command opens channel 104 but no other channels close. Executing STEP again closes channel 105. The 0 channel at the end simply opens the last channel closed.

Using the STEP Command

The STEP command is used to sequence through a scan list. If STEP is executed and no scan list has been specified, an error will occur.

The 3488A uses a "pointer" to keep track of which channel in the list is currently closed. Whenever STEP is executed, the 3488A checks the pointer. If the current channel is either a relay or a digital I/O line, that channel is opened and the next channel in the list is checked. If the next channel in the list is a relay or digital I/O line, that channel will be closed. If the next channel in the list is a stored setup, that setup is recalled.

If the current channel is a stored setup, the pointer simply moves to the next channel in the list. Channels that were closed by the setup will remain closed. Resetting the 3488A does not clear the scan list.

Using the OPEN, CLOSE, or Card RESET commands will have no effect on the scan list pointer, even though the channel pointed to may change state. Furthermore, other closed channels on an option will remain closed until they are reached in the scanning sequence.

When a RECALL command is executed outside of the scan list, the 3488A will restore the specified state and will search the scan list and reset the pointer if that setup is found. This operation is identical to recalling a stored setup during scanning using the STEP command. Channels closed by recalling a setup will remain closed.

Remember also, any 44474A Digital I/O option in either static mode 1 or 2 will have been saved and recalled. If the 44474A option was reset (all bits clear) when the setup was stored, they will be reset when the setup is recalled.

Using the CHAN command

CHAN is used to open any channel previously closed by either CHAN or STEP and then close the new channel specified. Contrast this with the CLOSE command that does not open any other channels.

If a Scan List is in effect when CHAN is executed, the 3488A will not only close the specified channel but will also search through the scan list looking for the specified channel. If that channel is found in the Scan List, the Scan List pointer will be repositioned to it. Therefore, when STEP is executed, the next channel closed will be the next channel in the list, not the first channel in the list.

If CHAN is used to close a channel that is not found in the scan list, and then STEP is executed, the 3488A will open the channel closed by CHAN and close the first channel in the Scan List.

Example

```
10 OUTPUT 709 ;"SLIST 100-109,205,207,209,0"  
20 OUTPUT 709 ;"CHAN103" ! Closes channel 103 and positions pointer to 103  
30 OUTPUT 709 ;"STEP" ! channel 103 opens and 104 closes  
40 OUTPUT 709 ;"CHAN 207" ! opens channel 104, closes 207 and pointer to 207  
50 OUTPUT 709 ;"CHAN 313" ! opens 207, closes 313 and pointer to 100
```

If CHAN is executed with no channel number specified, the 3488A will output the channel that was last closed by either CHAN or STEP. If neither CHAN nor STEP were executed since the last reset, channel 0 will be output.

For Example:

```
10 OUTPUT 709 ;"CHAN"  
20 ENTER 709 ; A  
30 DISP A
```

External Increment and Channel Closed

There is yet another way to step through the Scan List. External Increment is a feature of the 44474A Digital I/O option that can be used to sequence through a scan list without system computer intervention. A typical application of the External Increment (EI) feature is to connect it to the Voltmeter Complete* connector on a voltmeter. In this way, when the voltmeter has completed a measurement it will cause the 3488A to increment (STEP) its scan list.

In addition, a Channel Closed (CC) pulse is available from the 44474A Digital I/O option which can be used to trigger the voltmeter when the next channel closes. The CC pulse is a 10 μ S, TTL compatible pulse.

The following program shows how a voltmeter with internal reading storage capabilities (-hp- 3456A) makes the task of scanning very easy. The main advantage with this type of measurement system is speed. Overall measurement speed is not dependent on the system computer. Furthermore, the system computer can be performing other tasks while the voltmeter and 3488A are making the measurements. When the 3488A has reached the end of the scan list, it can interrupt the system computer.

* Voltmeter Complete is a feature on certain -hp- digital voltmeters that signals the completion of a measurement. This is done by outputting a digital (TTL level) pulse.

In this example we will use two 44470A Multiplexers (channels 100-209). Connect the common bus of both options to the voltmeter input terminals. Also, remember to connect the 3456's Voltmeter Complete and External Trigger to the 44474A's Channel Closed line and External Increment, respectively.

```

10 ! EXTERNAL INCREMENT AND CHANNEL CLOSED EXAMPLE
20 ! -HP- 85 VERSION WITH -HP- 3488A SWITCH AND -HP- 3456A DVM
30 ! 3488A AT ADDRESS 709, 3456A AT ADDRESS 722
40 CLEAR 7
50 OUTPUT 709 ;"SLIST 100-209,0; DMODE 5,1,1,1; MASK 1"
60 OUTPUT 722 ;"T2RS1"
70 ON INTR 7 GOSUB 1000
80 ENABLE INTR 7;8
90 TRIGGER 709
100 !
110 ! MAINLINE PROGRAM GOES HERE
120 !
990 END
1000 P=SPOLL(709)
1010 OUTPUT 722 ;"S01-20STRRER"
1020 FOR I=20 TO 1 STEP -1
1030 ENTER 722 ; A(I)
1040 NEXT I
1050 RETURN

```

Line	Description
40	CLEAR is used to reset the two instruments
50	This line sets the 3488A to the following conditions: SLIST 100-209 Scan list channels 100 to 209 DMODE 5,1,1,1 The 44474A option is in slot 5. It is set for handshake mode 1, polarity 1, and EI enabled. MASK 1 means End of Scan SRQ interrupt.
60	Sets 3456A to reading storage and external trigger.
70-80	Enables the -hp- 85 to respond to SRQ interrupt on End of Scan.
90	TRIGGER 709 same as STEP command for 3488A.
100	Body of the mainline program goes here.
1000	Serial Poll to clear the 3488A's interrupt.
1010	Set 3456A to recall readings
1020-1040	Recall the readings to the system computer. (last reading taken is first reading read back)

As noted before, using Channel Closed or External Increment requires the use of a 44474A Digital I/O option. This deprives the user of the PFLG handshake line because it is used as EI. In other words, the Digital I/O option cannot be configured in the handshake mode when it is used for scanning. The program demonstrates the use of the DMODE command (for enabling EI) which is discussed in the next section.

Only one 44474A Digital option card at a time may be configured for EI scanning. If one card is enabled and another is subsequently enabled, the first will become disabled (and CC will be routed to the new card). A CC pulse will be generated whenever either STEP or CHAN is executed if the Digital I/O card is enabled for EI.

Card Pair

Card Pair is used to pair up two option assemblies of the same type, for example, two 44470A's. This operation effectively assigns both options to both slot numbers so that closing or opening a channel on either option performs the same operation on the corresponding channel on the paired option. This feature is especially useful when doing 4-wire scanning using a scan list.

Assigning the card pairs is accomplished with the CPAIR command. For example, to assign the options in slots 1 and 3 as a pair, execute: CPAIR 1,3

Two pairs of slots may be asserted at any time as long as they do not share a common slot. You can, for example, assign slot 1 with 3 as one pair and slot 4 with 5 as a second pair. Executing a Card Pair command will cancel any previous Card Pairing that involved either of the two specified slots.

To illustrate the CPAIR command, assume there are two 44470A Multiplexer options, one installed in slot 1, the second in slot 3. The command CPAIR 1,3 pairs the two options together. If you now execute CLOSE 105, both channels 105 and 305 will close. Likewise, if you execute CLOSE 307, both channels 307 and 107 will close.

The commands that can be used with CPAIR are: CLOSE, OPEN, CRESET, CHAN and STEP. The CHAN and STEP commands make the CPAIR feature useful for scanning. If two 44474A Digital I/O options are paired together, the DWRITE command can be used to write the same value to both options.

If CPAIR is executed with no slots specified, the 3488A will return the current slot pair information. When responding over HP-IB, four numbers are sent, separated by commas. The first two numbers specify the slots of pair 1, the second two numbers specify the slots of pair 2. For a front panel inquiry, the displayed response is preceded with the CPAIR: header and the two pairs are separated by spaces. The response for an inactive pair is 0,0 will be designated.

The following simple program illustrates the use of the Card Pair command.

```

10 ! CARD PAIR EXAMPLE
20 DIM A$(30)
30 OUTPUT 709 ;"CPAIR 1,2; CMON 2" ! setup card pair and card monitor
40 OUTPUT 709 ;"CPAIR" ! return card pair
50 ENTER 709 ; A$
60 DISP A$ ! A$ will show cards 1 and 2 paired together
70 OUTPUT 709 ;"SLIST 100-109" ! setup scan list
80 FOR I=1 TO 10
90 OUTPUT 709 ;"STEP" ! Step through scan list
100 WAIT 100
110 NEXT I
120 END

```

Using the Time Delay

When using the External Increment and Channel Closed features, a time delay can be programmed between when the channel is closed and when the CC pulse is output. This time delay can be used to allow test signals to settle before the measurement is made.

You specify the delay time as any time period between 0 and 32,767 mS (32.767 seconds) in 1 mS intervals. For example, to set an 0.1 second delay, execute: DELAY 100.

If no time period is specified with the DELAY command, the 3488A responds with the current value of the delay. For example:

```

10 OUTPUT 709 ;"DELAY"
20 ENTER 709 ; A
30 DISP A

```

Figure 3-1 shows the timing relationships for the scanning sequence using EI and CC. If either EI or the HP-IB TRIGGER command is received by the 3488A during the delay time, the instrument will wait until the delay time is complete before executing the channel STEP. If External Increment is received while the 3488A is executing a previous EI, an error will be generated (Trigger too fast) and STEP will be executed.

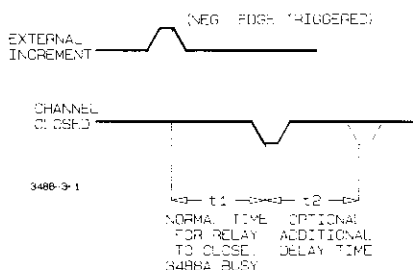

Figure 3-1. Delay Timing

COMMAND DIRECTORY

This command table for the 3488A is divided into three main categories:

- ▶ Standard Commands, appropriate for all 3488A option assemblies.
- ▶ Digital Commands used particularly with the 44474A Digital I/O module
- ▶ 3488A System commands

Refer to Chapters 2 and 3 in this manual for more information on channel addressing, etc. The following format is used to describe the commands.

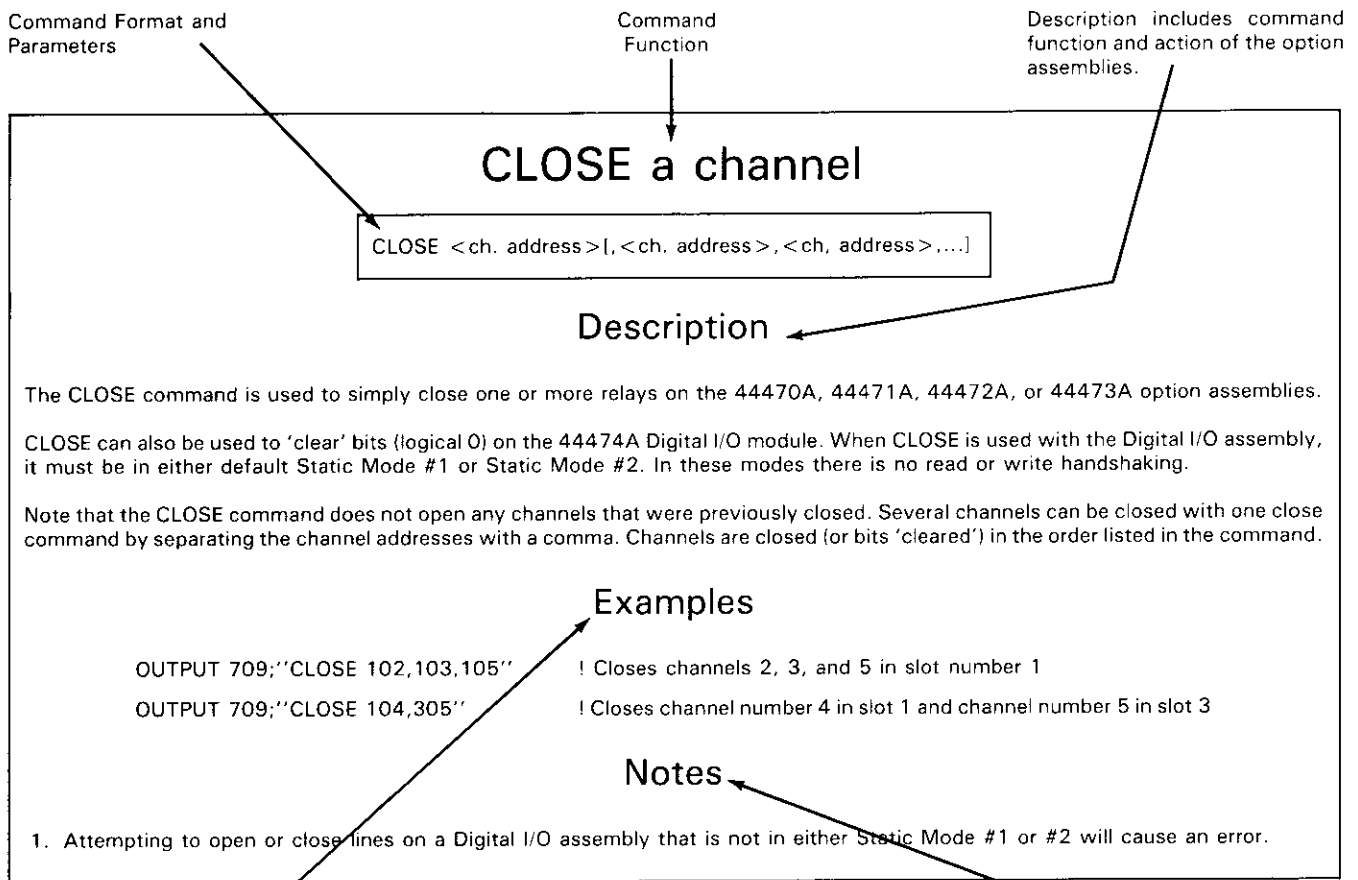

Examples are typical BASIC language statements with the 3488A at HP-IB address 709.

Notes include power-on state, where to look for more information, and special operating notes.

The 3488A expects numbers in either integer or floating point format. Note however, that numbers in floating point format are rounded to the nearest integer. For example, the command CLOSE 202.37 will be interpreted as CLOSE 202; CLOSE 202.5 will be interpreted as CLOSE 203. Numbers in exponential format will cause an error. Multiple commands separated by semicolons (;) may be used on one OUTPUT command.

Channel and bit address definitions adhere to the following conventions for the various option assemblies.

44470A 10 Channel Relay Multiplexer Module

Channel address is a three digit number. The first digit refers to the 3488A slot where the assembly is installed. This must be a number from 1 to 5. The next two digits refer to the specific channel number (00 - 09) on the assembly.

44471A 10 Channel General Purpose Relay Module

Channel address is a three digit number. The first digit refers to the 3488A slot where the assembly is installed. This must be a number from 1 to 5. The next two digits refer to the specific channel number (00 - 09) on the assembly.

44472A Dual 4 Channel VHF Switch

Channel address is a three digit number. The first digit refers to the 3488A slot where the assembly is installed. This must be a number from 1 to 5. The next digit refers to a specific channel group on the assembly. The third digit refers to a specific relay in that group. Relays are assigned channel numbers 00 - 03 and 10 - 13, corresponding to relay groups 0 and 1 respectively.

44473A 4X4 Matrix Switch Module

Channel address is a three digit number. The first digit refers to the 3488A slot where the assembly is installed. This must be a number from 1 to 5. The next digit represents the row (0 - 3) where the switch is located, and the third digit represents the column (0 - 3).

44474A 16 Channel Digital I/O Module

Bit address (used with CLOSE and OPEN) is a three digit number. The first digit refers to the 3488A slot where the assembly is installed. This must be a number from 1 to 5. The next two digits refer to a specific bit (00 - 15) on the assembly. Refer to Chapter 10 for more information on port modes and handshake modes.

In the following command descriptions, items in square brackets ([]) are optional, whereas items in <> brackets are mandatory.

CLOSE a channel

```
CLOSE <ch. address>[,<ch. address>,<ch. address>,...]
```

Description

The CLOSE command is used to simply close one or more relays on the 44470A, 44471A, 44472A, or 44473A option assemblies.

CLOSE can also be used to 'clear' bits (logical 0) on the 44474A Digital I/O module. When CLOSE is used with the Digital I/O assembly, it must be in either default Static Mode #1 or Static Mode #2. In these modes there is no read or write handshaking.

Note that the CLOSE command does not open any channels that were previously closed. Several channels can be closed with one close command by separating the channel addresses with a comma. Channels are closed (or bits 'cleared') in the order listed in the command.

Examples

```
OUTPUT 709;"CLOSE 102,103,105"      ! Closes channels 2, 3, and 5 in slot number 1
OUTPUT 709;"CLOSE 104,305"          ! Closes channel number 4 in slot 1 and channel number 5 in slot 3
```

Notes

1. Attempting to open or close lines on a Digital I/O assembly that is not in either Static Mode #1 or #2 will cause an error.

OPEN a channel

```
OPEN <ch. address>[,<ch. address>,<ch. address>...]
```

Description

OPEN is used to open individual relays on the 44470A, 44471A, 44472A and 44473A assemblies. Relays are opened in the order listed.

In addition, OPEN can also be used to 'set' (logical 1) individual bits on the 44474A Digital I/O assembly. The Digital I/O assembly must be in either the default Static Mode #1 or Static Mode #2. In either static mode there is no read or write handshaking.

Examples

```
OUTPUT 709;"OPEN 103,105,107"      ! Relays 3, 5, and 7 are opened in slot number 1
```

Notes

1. Attempting to open or close lines on a Digital I/O assembly that is not in either Static Mode #1 or #2 will cause an error.
2. Use the CARD RESET command to open all relays or set all digital I/O bits on an assembly. It is easier than listing each channel individually.

VIEW a channel

VIEW <ch. address>

Description

The VIEW command is used to look at the state, either open or closed of a particular channel or digital I-O bit. The 3488A responds with the string "OPEN 1" if the specified channel is open. If the specified channel is closed, the 3488A responds with the string "CLOSED 0". In the 3488A display, the channel address is displayed followed by a colon and the appropriate string.

Example

```

OUTPUT 709;"VIEW 105"      ! VIEWs channel 5 on slot number 1
ENTER 709; A$              ! input alphanumeric response from the 3488A
DISP A$                    ! A$ will either be "OPEN 1" or "CLOSED 0"

      or

ENTER 709; A               ! input numeric response from the 3488A
DISP A                     ! "A" will be either 1 or 0 for open or closed, respectively
    
```

Notes

1. When VIEWing a 44474A Digital line (bit), OPEN 1 means that the bit is set (pulled high, - 5 volt). CLOSED 0 indicates that the bit is cleared (low impedance to ground).

CARD TYPE

CTYPE <slot>

Description

This command causes the 3488A to output the model name and number of the option module installed in the specified slot. If CTYPE is executed from the keyboard, the display shows both the slot and the option model number.

Card Type	Description	
Slot is empty	NO CARD	00000
10 Channel Multiplexer	RELAY MUX	44470
General Purpose Card	GP RELAY	44471
High Frequency Scanner	VHF SW	44472
Matrix Card	MATRIX SW	44473
Digital I/O Card	DIGITAL IO	44474
Breadboard	BREADBOARD	44475

Example

```

OUTPUT 709;"CTYPE 3"      ! look for the card in slot 3
ENTER 709; A$            ! Card description will be displayed
DISP A$

      or

ENTER 709; A             ! only the numeric option model number is displayed i.e., "44470" for the 10 Ch. Multiplexer
DISP A
    
```

CARD RESET

```
CRESET <slot>[,<slot>,...]
```

Description

CARD RESET is used to reset all channels on the specified slot to their open state. Only options in the slots specified are affected. The 44474A Digital I/O option is reset to its default mode. This means that the 16 lines are set open (high impedance) and the option is in the Static Mode #1 (no handshaking).

Example

```
OUTPUT 709; "CRESET2" ! resets the option assembly in slot 2
```

CARD PAIR

```
CPAIR <slot>,<slot>
```

Description

CARD PAIR is used to pair up two cards of the same type, e.g., two 44470A's or two 44474A's. This operation will effectively assign both cards to both slot numbers so that closing or opening a channel on either card will perform the same operation on the respective channel on the other card. This feature is especially useful when doing 4-wire scanning with the 44470A's.

Executing a CPAIR command cancels any previous CPAIR command that involved either of the two cards. It is possible, however, to have two sets of card pairs, e.g. slots 1 paired with 2 and 3 paired with 4.

Example

```
OUTPUT 709; "CPAIR 1,3" ! sets the options in slots 1 and 3 as pairs
OUTPUT 709; "CLOSE 105" ! closes channels 105 and 305 simultaneously
```

CARD MONITOR mode

CMON <slot>

Description

CARD MONITOR places the 3488A display in a mode where it is dedicated to monitoring the option assembly in the specified slot (1 - 5). Specifying slot 0 causes the monitor mode to be cancelled.

Each option's monitor display and its meaning are summarized in the following displays:

44470A Multiplexer s: n,n,n,n,n,n,n,n,n

44471A General Purpose s: n,n,n,n,n,n,n,n,n

44472A VHF Multiplexer s: n,n,n,n;n,n,n

44473A Matrix (monitoring Rows) s: ROW r ;c,c,c,c

44473A Matrix (monitoring Columns) s: r,r,r,r; COL c

44474A Digital I/O
(Decimal monitoring of bytes) s: H:bbb L:bbb

44474A Digital I/O
(Hexadecimal monitoring of bytes) s: H:bbH L:bbH

44474A Digital I/O
(Decimal monitoring of word) s: W:wwwww

44474A Digital I/O
(Hexadecimal monitoring of word) s: W:wwwH

where:

- s = slot number
- n = channel number
- r = row number
- c = column number
- bbb = digital data byte
- www = digital data word

Example

OUTPUT 709: "CMON 1" ! monitor only slot 1

OUTPUT 709: "CMON -1" ! monitor tracking mode starting with slot 1

Notes

1. A decimal point after the data byte or word on the 44474A monitor display indicates the port is configured as a write port.
2. When monitoring the 44474A Digital I/O option, pressing the front panel arrow keys causes the mode to toggle between decimal and hexadecimal display.
3. Monitor Tracking mode is asserted by specifying a negative slot number. The monitor starts with the specified slot but tracks to subsequent slots where channels are closed or opened. In other words, the monitor display shows the option slot where the last channel closure or opening took place.
4. Turn card monitor off by executing CMON 0.

SCAN LIST

```
SLIST [<ch. address>[, or -]<ch. address>...<ch. address>]
```

Description

Scanning allows you to specify a sequence of channels to be scanned. The sequence is specified as a list of up to 85 channel addresses (relay or digital I/O) and/or stored setups separated by commas. Channels from any of the option assemblies may be included in the list. Contiguous channels may be specified by entering the first channel address and the last channel address separated by a hyphen.

Use the STEP command to sequence through the scan list. When STEP is used to initiate scanning, the first channel in the list will be closed. Subsequently executing STEP causes the currently closed channel to open and the next channel in the list to close.

Normally, executing STEP after the end of the scan list is reached causes a wraparound to the beginning of the list. However, the number 0 may be inserted in the scan list to act as a stop channel. When "0" is reached in the course of scanning, the 3488A will open the last channel closed but will not close another channel and the Channel Closed pulse will not be generated.

CHAN may be used to specify a particular channel to close. If CHAN is used, any channel previously closed in the scan list will open and the channel specified by CHAN will close. In addition, if the channel closed by CHAN is specified in the scan list, subsequent scanning with the STEP command will start with that channel.

Example

```
OUTPUT 709;"SLIST104,205,300-309,410"
```

In this example, the scan list starts with channel 104, followed by channel 205, followed by channels 300, 301, 302, ... 309 and finally channel 410.

Notes

1. Any gaps or improper card types included in a [channel-channel] sequence will be ignored as long as the two numbers specified are valid.
2. Relays may be scanned in any sequence, i.e., 309-300.
3. STEPPing beyond the last channel specified in the scan list causes a wraparound to the first channel in the list unless "0" is used as stop channel.
4. Refer to the Advanced Operation section of this manual for information on using the External Increment and Channel Closed features.
5. If CHAN is used to close a channel outside of the scan list and then STEP is executed, the 3488A will open the channel first closed by CHAN and then close the first channel in the scan list.
6. The commands OPEN, CLOSE, CRESET, or RECALL will have no effect on the scan list even though the state of individual channels may change. Conversely, STEP, CHAN and SLIST have no effect on channels closed by CLOSE, or RECALL if those channels do not exist in the scan list.
7. Stored setups are specified by a number from 1 to 40 inclusive. See STORE and RECALL.

STEPing through the channel list

STEP

Description

The STEP command is used to sequence through a scan list. If STEP is executed and no scan list exists, the 3488A will generate an execution error; ERR 2.

Example

```
10 OUTPUT 709;"SLIST100-109,0;CMON 1"      ! sets up scan list
20 FOR I=1 TO 10
30 OUTPUT 709;"STEP"                      ! STEPs through the scan list
40 NEXT I
```

Notes

1. For more information, see topics of Channel Closed and External Increment.

CHANnel command

CHAN [<ch. address>]

Description

CHAN is used to open the last channel closed by either STEP or CHAN and close the specified channel. If no channel is specified with CHAN, the 3488A will display or output to the interface the number of the last channel closed by either STEP or CHAN. If no channel has been closed since the last reset, then CHAN returns the number 0.

Example

```
OUTPUT 709;"CHAN 105" ! Any channel previously closed by CHAN or STEP will open and channel 105 will close
```

Digital Mode Command

DMODE <slot>[, <mode>][, <polarity>][, <EI>]

Description

Digital Mode is used to establish the handshake mode and polarity of the 44474A Digital I/O assembly. It is also used to enable the External Increment and Channel Closed Pulse functions. The Mode specifier is as follows:

Mode Type	Value
Static (default) Mode	1
Static 2 (read what was written)	2
R/W & Strobe mode	3
Read & Write Strobe mode	4
Handshake (no Ext. Inc.) mode	5

The polarity specifier is as follows:

Definition	Value
Lower byte polarity	1 = low true
Upper byte polarity	2 = low true
PCTL Polarity (low ready)	4 = low busy
PFLG Polarity (low ready)	8 = low busy
I/O direction line polarity (High = input mode normally)	16 = low input mode

External Increment and Channel closed is enabled by a 1 in the EI specifier. They are disabled with an EI specifier of 0.

Example

OUTPUT715: "DMODE5,1,0,1" ! set the EXT. INC. & CH. CLOSED Mode and STATIC Mode #1

Notes

1. Contents of the DMODE register can be read by deleting the parameters and executing only: DMODE <slot>. The 3488A will respond with a display in the same form as you would send to set the DMODE in. (i.e., mode, polarity, EI)
2. At power on, all 44474A Digital I/O assemblies are put in Static Mode, with High True Logic on all lines, EI/CC are disabled.
3. For a more detailed explanation of the DMODE command, refer to Chapter 10.

Write to a Digital I/O

```
DWRITE <slot> <port> , <data> [, <data> ]...
```

Description

Digital Write configures all or part of the 44474A to digital output ports and writes data to it. The 'PORT' portion of the command is always a two digit number and determines whether the high order eight bit byte (port 01) is written to, the low order eight bit byte (port 00) or the entire 16 bit word (port 02).

Example

```
OUTPUT 715; "DWRITE 501,124"      ! Write the value 124 to Slot 5, port 01
OUTPUT 715; "DWRITE 502,24561"    ! Write the value 24561 to the 16-bit port (port 02)
```

Notes

1. When writing to either of the 8-bit ports (ports 00 or 01), the value of the Data parameter must be between 0 and 255. When writing to the 16-bit port (port 02), the Data value can be between - 32768 and + 32767.
2. There is no limit to the number of data items that can be sent with the Digital Write command.
3. In the 16 bit mode (port 02) the data must be sent in 2's complement format.

Read From a Digital I/O

```
DREAD <slot> <port> [, # of times to read]
```

Description

Digital Read allows you to read the current status of the 44474A ports designated as inputs. The decimal value read back is equal to the sum of the values of the bits that are set. See the DWRITE command for an explanation of the port specifier.

Example

```
OUTPUT 715; "DREAD 502"          ! Read the 16-bit input port one time only
OUTPUT 715; "DREAD500,10"       ! Read the low order 8-bit port 10 times
```

Notes

1. If no value for number of reading is given, the specified port will be read only once.
2. The maximum number of times a port can be read with this command is 32767. For multiple readings, the 3488A must be in OLAP 1 mode.
3. When reading an 8 bit port, the values read back will be between 0 and 255. When reading the 16-bit port, the values read back will be between - 32768 and + 32767 (2's complement format).

Delay

DELAY [<time in mS>]

Description

The DELAY command is used to insert a time delay between the time that a channel is closed and the time that the next command can be executed and the Channel Closed pulse is output. The delay time can be specified from 0 to 32767 mS (32.767 seconds) in 1 mS increments. The delay time does not become effective until either CHAN or STEP is executed.

If there is not a time value sent with the DELAY command, the 3488A will respond by displaying the current value of the delay time.

Remember that the Channel Closed pulse will use whichever 44474A assembly has External Increment enabled.

Example

OUTPUT 715; "DELAY 45" ! The delay time is 45 mS = .045 Sec.

Notes

1. Commands received by the 3488A during the delay time will be executed after the delay time is complete.

Digital Binary Write

DBW <slot> <port> ,#I<block of data>

Description

When the DBW command is received, the 3488A will interpret the block of data information that follows as a block of binary data to be output according to the slot/port specification and DMODE (polarity, handshake) command. In 16-bit mode (port 02), the data block is interpreted as being most significant byte first. The transfer is completed by setting the HP-IB EOI line true concurrently with the last byte of data.

Example

The following example is for an -hp- Series 80 computer:

```

10 CONTROL 7,16;128           ! Sets computer for EOI on last data byte
20 DIM A$(30)
30 IOBUFFER A$
40 A$="CMON5;DBW502,#IAS"    ! "AS" is block of data sent to 44474A
50 TRANSFER A$ TO 709 INTR
    
```

Digital Binary Read

DBR <slot> <port> ,[<number of times to read>]

Description

In the Digital Binary Read mode, data items are read and output according to the format setup by the slot/port specifier and the DMODE (for polarity and handshaking) command. If the 16-bit mode (port 01) is specified, data will be sent with the most significant byte first. The data transfer is terminated with the 3488A setting the HP-IB EOI line true concurrently with the last data byte sent.

When requesting multiple readings, the 3488A must be in the OLAP1 mode. The maximum number of readings that may be specified is 32,767.

Example

```

10 DIM A$(30)
20 IOBUFFER A$
30 A$="DBR502,1"              ! one digital binary reading
40 TRANSFER A$ TO 709 INTR
50 ENTER 709 USING "%,K"; B$  ! qualifiers "%,K" set computer to concurrent EOI and last data byte.
60 DISP B$
    
```

Reset the 3488A

RESET

Description

The RESET command is used to reset the 3488A to its power-on state. This includes the following sequence.

1. Identify all option assemblies and reset them (all relays open).
2. Read HP IB address switches to establish the HP-IB address.
3. Set all parameters to their default conditions.

The following exceptions are made:

1. If RESET is executed from the system computer, interface functions are not affected (i.e., the 3488A stays in Remote mode, etc.). If the front panel RESET key is pressed, interface functions are reset.
2. Stored States are not destroyed (see STORE and RECALL).

Example

OUTPUT 709; "RESET"

Perform Internal 3488A Self Test

TEST

Description

TEST causes the 3488A to perform its internal self tests. When TEST is executed remotely from the system computer, only the internal tests are performed. When all the tests have passed, the message "SELF TEST OK" appears in the display. If any tests have failed, the message "FAILED nn" is displayed where nn is the sum of the values of the tests that have failed. Results of the tests can also be read back to the system computer; a value of 0 read back indicates all tests have passed.

Example

OUTPUT 709; "TEST"
ENTER 709; A
DISP A

When the front panel TEST key is pressed, the tests begin by turning on every segment in the display (except the top dot on the colon.) Following this, a complete power-on self test is performed. If no failures are found, the display indicates "SELF-TEST OK." If a failure is found, "FAILED nn" is displayed where nn is the sum of the values of all errors found.

The following table shows all possible failures and associated values.

- 1: RAM (Random Access Memory) failed
- 2: ROM (Read Only Memory) failed
- 4: Timer failed (used for delay, etc.)
- 8: IO chip failed (HP-IB interface)

Identify the 3488A

ID?

Description

If the 3488A is addressed to talk after sending the ID? command, it will output the string: HP3488A. This allows you to identify the HP-IB address of the 3488A.

Example

```

10 OUTPUT 709; "ID?"
20 ENTER 709; A$
30 DISP A$           ! The computer display should show: HP3488A

OR

20 ENTER 709; A
30 DISP A           ! The computer display should show: 3488
    
```

Status of the 3488A

STATUS

Description

STATUS permits reading the 3488A's Status Byte (See also SPOLL, Chapter 4). The STATUS command returns a decimal value which is the sum of the values of the individual bits that are set (condition is true).

Bits 0, 2, and 3 will be cleared after the STATUS command is executed. Bit 1 will be cleared only after the data is read from the 3488A, new data is requested, or the 3488A is reset. The Ready for Instructions bit (bit 4) will be cleared whenever the 3488A is busy executing instruction. For this reason, bit 4 will always be clear when STATUS is executed. SPOLL should be used to determine when the 3488A is ready for instructions. The Error bit (bit 5) will only be cleared after the Error Register is read. Bit 6, RQS, will only be cleared after STATUS if the condition that caused bit 6 to be set is cleared.

The following table shows the bits and their values.

Bit	Weighted Value	Definition
0	1	End of scan sequence
1	2	Output available
2	4	Power-on SRQ asserted
3	8	Front panel SRQ key pressed
4	16	Ready for instructions
5	32	Error
6	64	RQS
7	128	Not used

Example

```

10 OUTPUT 709; "STATUS"
20 ENTER 709; A
30 DISP A
    
```

Store the current channel setup

STORE <register number 1 to 40>

Description

Store is used to record the current state of the 3488A (closed channels, static digital output states, etc.) in the specified register number. This setup can be used later to return the 3488A to that state, it can also be used as part of a scan list.

Example

OUTPUT 709; "CLOSE 103,105,203,204,205; STORE 25"
This command stores the channel setup in register 25

OUTPUT 709; "RECALL 25"
This command recalls the setup from register 25

Notes

1. 44474A Digital I/O assemblies that are not in static mode are ignored.
2. The 3488A will not change the state of any channels when STORE is executed.
3. Resetting the 3488A does not affect the stored setups.

Recall the stored states

RECALL <register number 1 to 40>

Description

Once a setup has been stored, the RECALL command is used to re-assert that setup. When a stored state is recalled, the 3488A reconfigures itself, one slot at a time, beginning with slot 1, relay 00. Only relays and static Digital Outputs are recalled. This means that only those channels that are closed in the stored setup will be closed when the setup is recalled.

Example

OUTPUT 709; "CLOSE 103,104,202,204,206; STORE 10"
This command stores the channel setup in register 10

OUTPUT 709; "RECALL 10"
This command recalls register 10

Notes

1. If no state has been stored in the setup number selected, an error will result and the 3488A will send SRQ if it was enabled (see MASK). In this case, the 3488A remains in its previous state.

Error conditions

ERROR

Description

Error allows you to read the 3488A's error register. The decimal value returned is equal to the sum of the values of the possible error conditions, as defined below.

Weighted Value	Error Condition
1	Syntax Error
2	Execution Error possible meanings include: <ul style="list-style-type: none"> a. Parameter out of range b. Card type mismatch c. Attempt to access a nonexistent stored state or scan list.
4	Hardware Trigger too Fast
8	Logic Failure
16	Power Supply Failure

Example

```
10 OUTPUT 709; "ERROR"
20 ENTER 709; A
30 DISP A
```

Set the SRQ Mask

MASK [<decimal value>]

Description

The MASK command allows you to set the SRQ mask for certain conditions. (See Request Service, Chapter 4.) The decimal value loaded into the mask is equal to the sum of the values of the conditions that will cause an SRQ interrupt. The following table shows the possible conditions and values for an SRQ interrupt.

Mask Bit	Weighted Value	Description
0	1	End of Scan Sequence
1	2	Output Available
2	4	Power-on SRQ true
3	8	Front panel SRQ key pressed
4	16	Ready for instructions
5	32	Error
6		RQS (This bit is not maskable)
7		Not used

If no value is sent with the MASK command, the 3488A will display or output to the computer the current value of its SRQ mask.

Examples

```
OUTPUT 709;"MASK 8"      ! Set the mask for Front Panel SRQ Key
OUTPUT 709;"MASK 33"    ! Set mask for ERROR (32) and End of Scan Sequence (1)

10 OUTPUT 709; "MASK"
20 ENTER 709; A
30 DISP A                ! THE CURRENT MASK VALUE IS DISPLAYED
```

Overlap on received command strings

OLAP <1 or 0>

Description

In the Overlap disabled mode (default, OLAP 0), the 3488A holds up HP-IB I/O communications while it processes received messages. If Overlap is enabled (OLAP1), the 3488A will release the HP-IB as soon as the command message is received. Overlap enabled allows faster I/O operations but does not guarantee sequential operation of other devices on the bus. For more information, refer to Chapter 4.

Example

OUTPUT 709; "OLAP 1" ! Overlap is enabled

Notes

1. Overlap goes into effect on the first Bus communication after the OLAP message sent.
2. Overlap is only for commands received by the 3488A, not for data sent by the 3488A.
3. Default is Overlap disabled.
4. In Overlap enabled, users should monitor bit 4 in the 3488A Status Register to help insure sequential operation of other instruments on the HP-IB interface.
5. OLAP 1 is necessary for multiple readings from the 44474A Digital I/O option with the DREAD and DBR commands.

Stop on an Error (Error Halt)

EHALT <0 or 1>

Description

This command is used to enable (EHALT 1) the stop-on-error mode of the 3488A. When the 3488A discovers an error (see ERROR command), it will lockup the HP-IB interface (no HP-IB communication). ONCE THE HP-IB IS LOCKED UP, YOU MUST RESET THE HP-IB INTERFACE. THE 3488A CAN BE RESET BY EITHER PRESSING THE FRONT PANEL LOCAL KEY OR EXECUTING THE HP-IB CLEAR COMMAND. Default condition is EHALT disabled (EHALT 0) which allows HP-IB communication after an error is discovered.

Example

10 OUTPUT 709; "EHALT 1"

Write to the 3488A Display

```
DISP < ASCII character string >
```

Description

DISP lets you write messages up to 127 characters long to the 3488A's display. Any printable ASCII character (decimal value 32 and greater) can be displayed except for colons (:), semicolons (;) and pound signs (#). These two characters are interpreted as terminators thus ending the string. All other characters and any characters in excess of 127 will be discarded. Use the two arrow keys to scroll the display.

Example

```
OUTPUT 709; "DISP THIS IS THE 3488A SWITCH:CONTROL UNIT"
```

Notes

1. Delimiters such as Line Feed (lf), Carriage Return (cr), colons and semicolons are not allowed in the data string and will cause a 3488A error.
2. Quotation Marks within the ASCII character string are ignored.

Turning the Display ON or OFF

```
DON or DOFF
```

Description

The DOFF command allows you to turn the 3488A's display off. This allows the 3488A to operate faster because it no longer needs to update the display. After DOFF has been executed, the display will show a series of hyphens and then turn off. This hyphen series may stay in the display for approximately 10 minutes before the display actually clears.

The display will be reactivated by either the DON command or pressing the LOCAL key. Use DON to remove a message written to the display with the DISP command.

Example

```
OUTPUT 709; "DOFF"
```

```
OUTPUT 709; "DON"
```

Lockout the Keyboard

```
LOCK 1 activates LOCKOUT  
LOCK 0 (default) deactivates LOCKOUT
```

LOCK is similar to sending the Local Lockout command from the computer. Locking out the keyboard prevents the keyboard from being scanned thus permitting faster operation.

Example

```
OUTPUT 709; "LOCK1" ! Lockout the keyboard
```

Chapter 4

Advanced Remote Programming

Introduction

This chapter discusses topics useful to programmers experienced in HP-IB remote programming. The vast majority of all 3488A remote programming can be done without knowing or using the material in this chapter.

Using the 3488A Input Buffer

The 3488A has two modes for receiving commands from the system computer: Sequential and Overlap (OLAP). Sequential Mode (which is the default mode) simply means that the 3488A will not complete the HP-IB handshake process until the received command has been fully executed. Refer to Appendix B for more information on HP-IB handshake.

Picture the Sequential Mode this way:

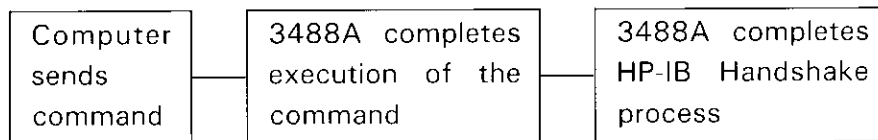

This means that the computer cannot send commands to any other device until the 3488A has completed execution of its command. This is beneficial because it guarantees that the 3488A will be ready (channel closed, etc.) before the computer tells some other device to do something (TRIGGER, etc.).

The Overlap Mode can be pictured like this:

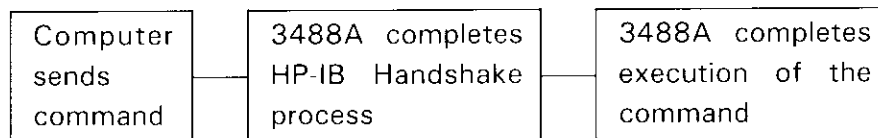

The advantage of the Overlap Mode is more "throughput". This means the computer can be performing other tasks while waiting for the 3488A to complete execution. Its disadvantage is that it does not guarantee sequential operation of other instruments on the interface bus.

The following two programs demonstrate the use of the Overlap mode. In the first program, with Overlap off, the 3488A will close channel 101 and then inhibit all HP-IB communication until the delay time is complete. When the delay is complete, the 3478A voltmeter is triggered.

In the second program, the 3488A releases the HP-IB interface allowing the voltmeter to trigger immediately, probably before the channel is closed. No other command will be executed by the 3488A until the delay time is complete.

Note in both program examples, the Overlap mode is asserted on a separate line in the program. This is because the Overlap mode (whether on or off) is not asserted until the next transmission from the system computer. Either carriage return (cr) line feed (lf) or some combination of two delimiters (e.g., two semicolons) must be received at the end of all command strings for OLAP off to work properly.

```
10 ! OVERLAP OFF EXAMPLE
20 ! -HP- 85 VERSION
30 ! 3488A AT ADDRESS 709, 3478A AT ADDRESS 723
40 CLEAR 7
50 OUTPUT 723 ;"T3" ! 3478A in single trigger mode
60 OUTPUT 709 ;"OLAP 0" ! default condition
70 OUTPUT 709 ;"DELAY 5000; CHAN 101"
80 TRIGGER 723 ! trigger the voltmeter
90 END
```

```
10 ! OVERLAP ON EXAMPLE
20 ! -HP- 85 VERSION
30 ! 3488A AT ADDRESS 709, 3478A AT ADDRESS 723
40 CLEAR 7
50 OUTPUT 723 ;"T3" ! 3478A in single trigger mode
60 OUTPUT 709 ;"OLAP 1" ! overlap mode on
70 OUTPUT 709 ;"DELAY 5000; CHAN 101"
80 TRIGGER 723 ! trigger the voltmeter
90 END
```

With the Overlap mode on, the Ready bit in the 3488A's Status Register can be checked with a serial poll (SPOLL, discussed later in this chapter) to insure sequential operation. Do not use the 3488A's STATUS command because the instrument will be busy executing the STATUS command and therefore the Ready bit will always be clear.

The next program shows how to continuously monitor the Status byte with a Serial Poll (SPOLL) to determine when the 3488A has completed its task and is ready for the next event to occur. Bit 4 in the Status byte is the Ready for instruction bit and is checked in program line 80.

```

10 ! MONITOR STATUS BYTE EXAMPLE
20 ! -HP- 85 VERSION
30 ! 3488A AT ADDRESS 709
40 CLEAR 7
50 OUTPUT 723 ;"T3"
60 OUTPUT 709 ;"OLAP 1" ! overlap mode on
70 OUTPUT 709 ;"DELAY 10000;CHAN101"
80 P=SPOLL(709)
90 IF BIT(P,4)<>1 THEN GOTO 70
100 TRIGGER 723
110 END

```



Command

OLAP1 turns Overlap on
 OLAP0 turns Overlap off

3488A HP-IB Capabilities

The following topics, arranged in alphabetical order, deal with specific HP-IB command messages (see Appendix B). These commands are functions of the HP-IB interface and all HP-IB compatible instruments will respond, in some manner, to them. Refer to the remote HP-IB programming manual for each instrument connected to the interface of your test system to see how they respond to these commands.

Refer also to the I/O programming manual for the computer you are using for specific information on the syntax and actions taken by the interface when sending the messages. The examples given here apply to the -hp- Series 80 and Series 200 desktop computers except where noted.

Many of the commands in this chapter have counterparts that can be executed from the 3488A front panel. This makes the commands both easy to learn as well as more valuable.

CLEAR

Examples

```
CLEAR 7    (device Clear)
CLEAR 709  (selected device Clear)
```

Comments

Upon receiving the CLEAR message, the 3488A will go into its reset routine. This means that all relays will open, the 44474A Digital I/O option will go to its default mode (all bits high impedance, static mode). Setups that have been stored are NOT destroyed.

LOCAL

Examples

```
LOCAL 7
LOCAL 709
```

Comments

The LOCAL 709 message clears the 3488A from the REMOTE mode and re-enables the front panel keyboard. Pressing the front panel LOCAL key accomplishes the same thing, provided the key has not been disabled with the LOCAL LOCKOUT message. LOCAL 7 removes every instrument on interface 7 from the REMOTE mode.

If the 3488A is in REMOTE with LOCAL LOCKOUT set (see next topic), the only way to return to front panel control is to either turn power off and then on again, or to execute the LOCAL 7 message. The command LOCAL 7 takes all instruments out of LOCAL LOCKOUT that are connected to that interface. The command LOCAL 709 would return the 3488A to front panel control but a subsequent REMOTE command (or OUTPUT 709) would return it to LOCAL LOCKOUT.

LOCAL LOCKOUT

Example

```
LOCAL LOCKOUT 7
```

Comments

The LOCAL LOCKOUT command locks out the 3488A's front panel keyboard including the LOCAL and SRQ keys. The lockout will remain in effect until it is cleared over the interface bus by sending the LOCAL message to the instrument or by cycling the 3488A's line switch.

REMOTE

Examples

```
REMOTE 7  
REMOTE 709
```

Comments

The REMOTE message is used to disable the 3488A's front panel switches (except the LOCAL and SRQ keys) and put it in remote program control. When the 3488A has been addressed to Listen, the REM annunciator in the display turns on to indicate that the instrument is in the Remote mode. To disable even the SRQ and LOCAL keys, use the LOCAL LOCKOUT message.

You will seldom find it necessary to execute the REMOTE command. The REMOTE command is independent of any other HP-IB activity and is sent on a single interface bus line called REN (see Appendix B). Most controllers set the REN line true at power-on or when reset, which has exactly the same effect as sending only REMOTE 7. Before any instrument will actually go into the remote state it must be addressed. Therefore, when the 3488A is first addressed, such as OUTPUT 709; "CLOSE 101", it will then go to the remote state.

REQUEST SERVICE (SRQ)

A very important feature of the 3488A is its ability to interrupt the system computer when certain specified conditions are met. Of course the system computer must be programmed to respond to the interrupt. The Require Service (SRQ) message is used to implement this feature and is independent of all other HP-IB activity. SRQ is sent on a single Interface Bus line (see Appendix B) called the SRQ line. The 3488A **MUST BE PROGRAMMED** to interrupt before it will actually attempt to interrupt the computer. The following list gives the possible causes of interrupt that the 3488A can be programmed for.

1. End of Scan Sequence. A series of channels can be designated as a scan list. The STEP command or HP-IB TRIGGER command causes the 3488A to increment through the scan list. When the last channel of the scan list is closed, the 3488A can interrupt the computer.

2. Output Available. If the computer has asked for some type of information, the 3488A can signal the computer that the information is available.

3. Power-on SRQ. The 3488A can interrupt the system computer when the 3488A is turned on (for example, if power to the 3488A were lost and later restored, the 3488A could signal the computer of the failure).

4. Front Panel SRQ. You can use the 3488A front panel SRQ key to manually interrupt the computer.

5. Ready for Instructions. When the 3488A completes some preassigned task, such as closing a list of relays, it can interrupt the computer. This is most useful in OLAP1 mode.

6. Error. There are several types of errors that can cause an interrupt. These include: syntax error, execution error, hardware trigger too fast, relay failure, and power supply failure. Refer to Chapter 2, Handling Errors, for more information.

How to Use SRQ

When the Require Service message (SRQ) is sent, the computer must first determine which instrument is requesting service (if more than one is capable of requesting service). This is done by conducting a SERIAL POLL (SPOLL) of each instrument connected to the interface. When an instrument is polled, it responds by sending a STATUS BYTE which indicates whether it requested service and if so, the nature of the request. If the Status Byte for the instrument polled indicates that the instrument was not requesting service, the computer would continue to poll the other instruments on the bus until the proper one is located. This, of course, assumes that the computer has been programmed to respond to SRQ and for the Serial Polling.

REQUEST SERVICE (SRQ) (Cont'd)

Status Register and Status Byte

The Status Register (see Status Command in Chapter 2) is used to monitor the six possible interrupt conditions. It is possible for one or more interrupt conditions to be true without the 3488A causing an interrupt. The interrupt will only occur when the SRQ mask has been set for particular conditions. Refer to Figure 4-1. Imagine the SRQ mask sitting over part of the Status Byte. If the SRQ mask is set for a certain condition, and that condition occurs, bit 6 of the Status Byte will go "true" (true being a logical 1). When bit 6 of the Status Byte is true, the 3488A will send the SRQ message to the computer and the SRQ annunciator will turn on. Remember, the system computer must be programmed to respond to the SRQ interrupt.

The Status Byte is an 8-bit byte that may be used to determine the current status of the 3488A regardless of whether an SRQ interrupt has occurred. The Status Byte comes from the Status Register and is output to the HP-IB in response to a Serial Poll or it can be displayed on the 3488A by pressing the STATUS key.

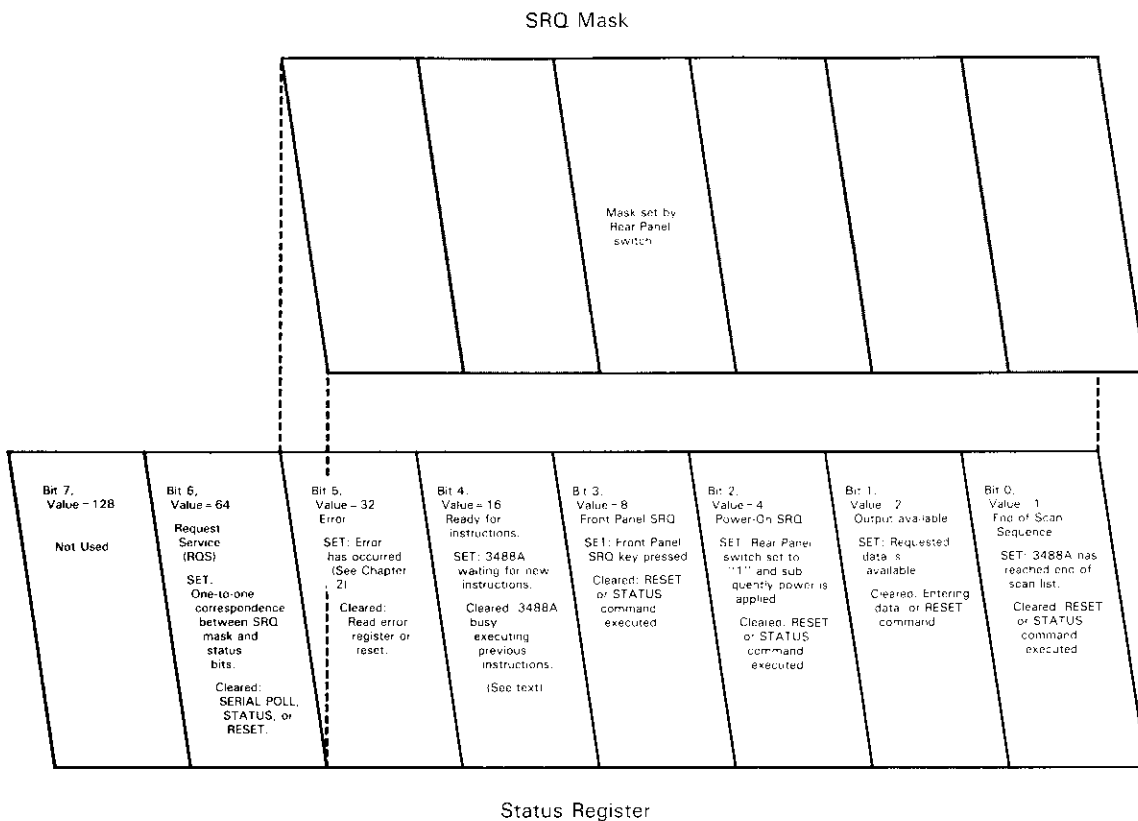

Figure 4-1. Status Byte and SRQ Mask

REQUEST SERVICE (SRQ) (Cont'd)

Setting the SRQ Mask

Setting the 3488A SRQ mask can be done from either the front panel or remotely from the system computer. The mask can even be interrogated to determine its setting.

The SRQ mask can only be set to mask bits 0 through 5 of the Status Register. Default mask value is 000. To set the mask, first determine which conditions you want to interrupt the system computer, e.g., End of Scan Sequence, Errors, Front Panel SRQ, etc. Sum together the weighted decimal values for those conditions (bits). Then, execute the MASK command with the decimal sum; that is, MASKxxx where xxx is the sum of the weighted values.

Do This:

To determine the current mask setting, execute the MASK command:

```
OUTPUT 709; "MASK"
```

```
ENTER 709; A
```

```
DISP A
```

"A" will have a value of 0.

or



The display should indicate: MASK: 000

Now, let's set the mask for front panel SRQ. To do this, look at Figure 4-1. The weighted value for front panel SRQ is 8. So execute:

```
OUTPUT 709; "MASK 8"
```

or



Verify that the mask is set to 8 by executing the MASK command.

Now, since the SRQ mask is set for front panel SRQ, pressing the SRQ key should cause the SRQ annunciator to turn on. This means that the 3488A is requesting service from the computer. But what is the benefit of all of this? The following examples demonstrate possible uses for the SRQ interrupts.

REQUEST SERVICE (SRQ) (Cont'd)

Example 1. Front Panel SRQ

The Front Panel SRQ feature of the 3488A provides you with a way of manually interrupting the controller from the instruments front panel. This feature is enabled by setting Bit 3 in the SRQ mask, command "MASK 8". Once this is done, pressing the 3488A front panel SRQ key causes the 3488A to request service (SRQ) from the system computer. The SRQ annunciator turns on in the display until the computer responds by executing a Serial Poll or a CLEAR command.

	Line	Description
10 Front panel SRQ example	40	The MASK 8 command sets the 3488A to respond to the front panel SRQ key.
20 -HP- 85 version		
30 3488A at address 709		
40 OUTPUT 709 : "MASK 8"	50	Line 50 tells the computer where to go in its program (line 1000) when an SRQ interrupt occurs.
50 ON INTR ? GOSUB 1000		
60 ENABLE INTR 7:8	60	ENABLE INTR actually enables the -hp- 85 computer to respond to interrupts on HP-IB interface 7. The number 8 is the octal code for SRQ interrupts (as described in the -hp- 85 I/O Programming Guide).
70 GOTO 60		
80 END		
1000 P=SPOLL(709)		
1010 IF BIT(P,3) THEN DISP "SRQ KEY PRESSED" ELSE DISP "P= ":P	70	Line 70 is a simple loop that allows the program to continue running until someone presses the SRQ key on the 3488A front panel.
1020 STATUS 7:1 : A		
1030 OUTPUT 709 : "STATUS"		
1040 RETURN		
	1000	SPOLL returns the 3488A Status Byte to variable P.
	1010	Bit 3 of the Status Byte is tested to make sure it is set. If it is, the message "SRQ KEY PRESSED" is displayed. If bit 3 is not set, something else caused the interrupt.
	1020	The STATUS command clears the -hp- 85 HP-IB Status/Control register so that it can respond to the next interrupt.
	1030	The Status register in the 3488A should be read and cleared so that it can cause future interrupts if necessary.
	1040	Return to where program was interrupted.

REQUEST SERVICE (SRQ) (Cont'd)

Example 2. SRQ on End of Scan Sequence

Scanning (see SCAN LIST, Chap. 2) is a feature of the 3488A that allows it to sequence through a series of channels. When the 3488A has reached the end of that series, it would interrupt the system computer (SRQ). This allows the computer to perform other tasks while the 3488A keeps track of the scanning progress.

To enable the SRQ feature in the 3488A, bit 0 of the SRQ mask must be set. Remember that bit 0 will be true any time the end of a scan list is reached, but for the SRQ interrupt to occur the SRQ mask must be set. The mask bit pattern for End of Scan Sequence would look like:

Bit #:	5	4	3	2	1	0
Value:	0	0	0	0	0	1

To set the SRQ mask, we need to execute the command: MASK 1. Now, when the 3488A reaches the end of a scan sequence, it will interrupt the system computer via SRQ. The computer will only be interrupted if bit 0 is true, meaning end of scan sequence. Bits 1 through 5 will not interrupt the computer because the mask was not set for those bits. When the scan sequence reaches its end, the SRQ annunciator turns on in the 3488A display and will remain on until the computer responds by doing a serial poll, executing the CLEAR command, or the 3488A is turned off.

Let's illustrate how the SRQ on End of Scan Sequence could be used. In this illustration, two 44470A Multiplexer assemblies are used to scan through 20 channels of test points. An -hp- 3456A voltmeter connects to the common bus of both 44470A assemblies and will be used for voltage measurements.

In this particular example, the Channel Closed and External Increment functions of the 44474A Digital I/O assembly will be used. When a channel is closed, the 3488A will output a Channel Closed Pulse to the 3456A's External Trigger. Thus, the 3456A takes one voltage reading. After the voltmeter has completed the reading for that channel, it will output a Voltmeter Complete pulse to the 3488A's External Increment line. This in turn causes the current channel to open and closes the next channel in the list. This cycle continues until the end of the scan list.

REQUEST SERVICE (SRQ) (Cont'd)

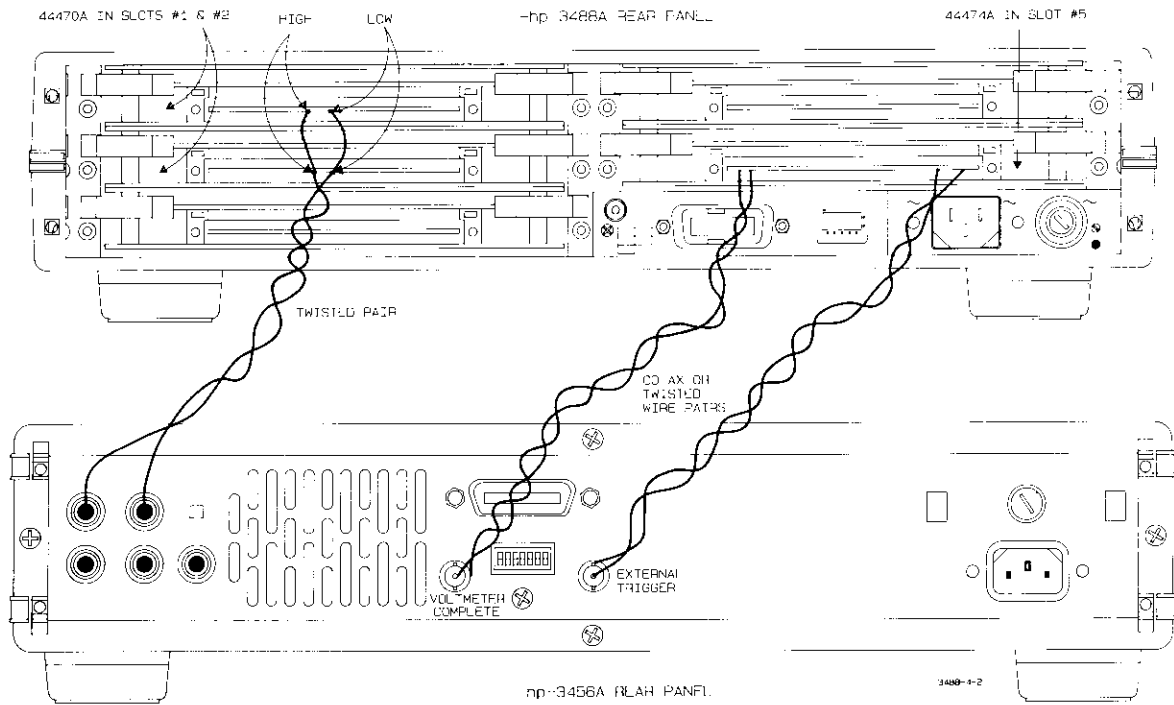

Figure 4-2. 3488A Channel Scanning

REQUEST SERVICE (SRQ) (Cont'd)

	Line	Description
10 ! End of Scan sequence SRQ e >ample	40	Instructs the computer where to go (line 1000) when an interrupt occurs on interface 7.
20 ! -HP- 85 version		
30 ! 3488a at address 709, 3456 A at address 722	50	ENABLE INTR 7;8 actually enables the -hp- 85 to respond to the SRQ. SRQ is octal code "8" in the -hp- 85 HP-IB control register.
40 ON INTR 7 GOSUB 1000		
50 ENABLE INTR 7;8		
60 OUTPUT 709 ;"SLIST 100-209,0 ; DMODE 3,1,0,1; MASK 1"	60	SLIST 100-209 sets the 3488A to scan the channels 100 through 209, these are the 44470A channels. The channel 0 means stop scanning. If the 0 is not used, the 3488A will start scanning through the channels again. DMODE 3,1,0,1 sets the 44474A (slot 3) for Channel Closed and External Increment. MASK 1 sets the SRQ mask for End of Scan SRQ.
70 OUTPUT 722 ;"FIRIZITZRSI"		
80 TRIGGER 709		
90 GOTO 90 ! Mainline Program e oes here		
100 END		
1000 P=SPOLL(709)		
1010 IF BIT(P,0) THEN DISP "END OF SCAN REACHED"		
1020 OUTPUT 722 ;"0020STR"		
1030 FOR I=1 TO 20		
1040 OUTPUT 722 ;"RER"		
1050 ENTER 722 ; R(I)	70	These commands set the 3456A for DCV, Auto ranging, Autozero on, External Trigger, and Reading Storage on; respectively.
1060 DISP R(I)		
1070 NEXT I		
1080 OUTPUT 722 ;"01"	80	TRIGGER 725 causes the 3488A to close the first channel in the list and begin the scan sequence.
1090 STATUS 7,1 ; R		
1100 OUTPUT 709 ;"STATUS"		
1110 RETURN		
	90-990	These lines contain the main body of the program.
	1000	This is the start of the interrupt subroutine. SPOLL returns the 3488A Status byte to variable "P".
	1010	If bit 0 in the 3488A Status Byte is set, then display the message. If the bit is not set, something else caused the interrupt.
	1020-1060	These line recall the 20 voltage readings from the 3456A.
	1070	This STATUS command is used to clear the -hp- 85's Status/Control Register so that it can respond to the next interrupt. Do not confuse this STATUS with the STATUS for the 3488A.
	1030	The Status register in the 3488A should be read and cleared so that it can cause future interrupts if necessary.
	1080	Return to where the program was interrupted.

S POLL

Example

P = S POLL (725)

Comments

Serial Poll (S POLL), like the 3488A STATUS command, allows you to determine the current status of your 3488A. When the 3488A receives the S POLL message, it returns the value of its Status Byte to the system computer. The value returned is the sum of the values of the individual bits that are set. Note that S POLL does not clear any of the bits in the Status Register except for bit 6, RQS. Use the STATUS command to clear the remaining bits.

S POLL differs from the STATUS command in that STATUS actually interrupts the internal processor. Thus, with STATUS, the 3488A will always appear busy (bit 4 clear). S POLL simply extracts the Status byte without interrupting the processor. Therefore, S POLL should always be used when determining the readiness of the instrument for further instructions (see OLAP).

The other main difference between S POLL and STATUS is with bit 1. If bit 1 is set, meaning data is available, and the STATUS command is sent, whatever data was available becomes lost and the value of the Status Byte replaces it in the output buffer. S POLL allows you to determine if data is available without destroying the data.

Figure 4-3 shows each of the eight bits in the Status Byte and their respective values. A description of the bits follows the figure.

Bit 7	Bit 6	Bit 5	Bit 4	Bit 3	Bit 2	Bit 1	Bit 0
Unused.	Set: SRQ interrupt.	Set: ERROR condition occurred.	Set: 3488A is ready for new instruction.	Set: Front Panel SRQ key has been pressed.	Set: Power On SRQ switch set and power-on occurred.	Set: Requested information is available.	Set: End of Scan List.
Always 0	Cleared: Condition causing SRQ is cleared or HP-IB S POLL command or 3488A is reset.	Cleared: Error register is read or 3488A is reset.	Cleared: 3488A is busy executing previous instruction.	Cleared: STATUS command or 3488A reset.	Cleared: STATUS command or 3488A is reset.	Cleared: STATUS command, reading the data, or resetting the 3488A. Note: STATUS deletes old information.	Cleared: STATUS command.

Figure 4-3. Status Byte

SPOLL (Cont'd)

- Bit 0 If a scan list has been set up and sequenced through, this bit
End of Scan will be set to a "1" when the last channel in the list is closed.
Sequence
(value = 1)
- Bit 1 This bit will be set when the computer asks for some piece of
Output information and the information becomes available. For example,
Available if the computer asks for the card type in slot 1, this bit will be
(value = 2) set when that information becomes available.
- Bit 2 This bit is set to a 1 when a power-on reset has occurred. If
Power-on the Power-on SRQ switch on the rear panel is set to the "1" or
SRQ "up" position, bit 6 in the Status Byte will also be set, generat-
(value = 4) ing an SRQ interrupt. Bit 2 will be cleared if a reset due to the
HP-IB CLEAR command or the RESET or STATUS keys on the
front panel are pressed.
- Bit 3 When bit 3 is set to a "1", it indicates that the front panel SRQ
Front Panel key has been pressed.
SRQ
(value = 8)
- Bit 4 This bit indicates that the 3488A has completed its last
Ready for command and is ready for the next command. Note: this bit will
Instructions always appear to be clear (low) (meaning busy) when executing
(value = 16) STATUS. This is because the 3488A is busy while executing
the STATUS command.
- Bit 5 When this bit is set, it indicates that an error of some type has
Errors occurred. Refer to Chapter 2, Handling Errors, for more informa-
(value = 32) tion on the nature of possible error messages.
- Bit 6 This bit indicates that the 3488A is requesting service (SRQ)
Service from the system computer. The bit is set to "1" whenever the
Request SRQ mask is set for a particular event and the event occurs.
(value = 64) This bit is also set to "1" at power on if the Power-on SRQ
switch (3488A rear panel) is set to the up position. This bit is
cleared by either a reset or a Serial Poll.
- Bit 7 This bit is not used and is always 0.

S POLL (Cont'd)

Try this simple exercise

Press the 3488A RESET key followed by the STATUS key. The display should show:

STATUS: 000

This indicates that none of the conditions are true. (Remember, Bit 4 is clear because the 3488A is busy executing the STATUS command and therefore not ready for more instructions until the command is finished.)

Now, execute the same commands from the system computer:

```
10 OUTPUT 709 ;"RESET"      10 OUTPUT 709 ;"RESET"  
20 OUTPUT 709 ;"STATUS"    20 A=SPOLL(709)  
30 ENTER 709 ; A           30 DISP A  
40 DISP A                  40 END  
50 END
```

The value of A should be 0 in the left hand example, and 16 (Ready for Instructions) in the right hand example.

Now, set up a simple scan list, for instance SLIST 200-202 and STEP through each of the channels. Execute lines 20 through 40 in either of the programs above (or simply press the STATUS key). The value returned should be 1 (End of Scan List) if you either pressed the STATUS key or executed the left hand program. If you executed the right hand program (SPOLL), the value returned is 17 (End of Scan List and Ready for Instructions).

Reset the 3488A and press the front panel SRQ key. Check the value of the Status byte. It should be either 8 (execute STATUS) or 24 (SPOLL).

TRIGGER

Examples

```
TRIGGER 7  
TRIGGER 709
```

Comments

If the 3488A has been addressed to listen, the TRIGGER message (also known as the GET for Group Execute Trigger) will cause the same action as the 3488A STEP command. In other words, the commands TRIGGER 709 and OUTPUT 709; "STEP" perform exactly the same function.

Chapter 5

Operator Information

Introduction

Your 3488A Switch/Control Unit was engineered for ease of use and reliability. The instrument was carefully inspected before shipping and should be free of mechanical and electrical flaws and should be in proper working condition.

The information in this chapter covers initial setup, installation and checkout of your new 3488A. This chapter should be read prior to installing the instrument for use. Warranty information, specifications, accessories, etc., are also covered in this chapter.

Preparation For Use

Unpacking Instructions

When you are unpacking your 3488A for the first time, make certain that the options that you ordered have been received with your 3488A. The following items should also have been included:

Qty.	Description
1	3488A Operating, Programming and Configuration Manual
1	3488A Mainframe Service Manual
1	Power cord
1	250mA line fuse and black fuse cap
1	500mA line fuse and gray fuse cap

WARNING

If any of the following symptoms exist, or are even suspected, remove the instrument from service. Do not use the instrument until safe operation can be verified by service-trained personnel.

- 1. Visible damage.*
- 2. Severe transport stress.*
- 3. Prolonged storage under adverse conditions.*
- 4. Failure to perform intended measurements or functions.*

If necessary, return the instrument to a Hewlett-Packard Sales and Service Office for service and repair to ensure that safety features are maintained.

Initial Inspection

Your 3488A was carefully inspected before it left the factory. It should be free of marks or scratches and in proper working order upon receipt. You should, however, inspect the instrument for any damage that may have occurred in transit.

If the shipping container or cushioning material is damaged, it should be kept until the contents of the shipment have been checked for completeness and the instrument has been mechanically and electronically inspected. Save the shipping materials for the carrier.

Procedures for checking the electrical performance of the 3488A are given in the 3488A SERVICE MANUAL. If there is any mechanical damage, the contents are incomplete, or the instrument fails to pass its Operational Verification or Performance Tests, promptly notify the nearest Hewlett-Packard office. A list of hp- Sales and Service Offices is located in the back of this manual.

CAUTION

Before connecting the 3488A to an ac power source, verify that the ac power source matches the setting of the 3488A line voltage selection switch.

Power Requirements

The 3488A requires a power source either 86-127Vac or 195-253Vac, 48 to 66 Hz single phase. Maximum power consumption is 15VA (Volt-Amps). Remove all options from the left side (facing the back panel of the instrument) and verify that the ac line voltage selection switch is set to the nominal line voltage for your area.

Line Voltage Selection

If it is necessary to reset the ac line voltage selection switch (Figure 5-1), turn the instrument power off and remove the power cord from the rear of the instrument. With a small flatblade screwdriver move the switch to the appropriate position.

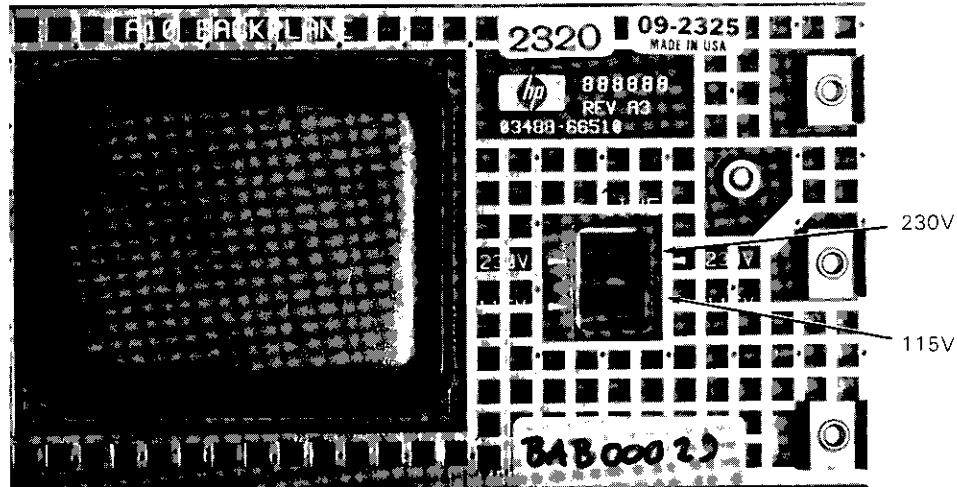

Figure 5-1. AC Line Voltage Selection Switch

Power Line Fuse Replacement

Two fuses with fuse caps and labels are provided with your 3488A. Select the one that is appropriate for the nominal line voltage in your area.

Replacement fuses are available from -hp- with the following part numbers:

Line Voltage	Power Line Fuse	Fuse Cap
115Vac Nominal (87 to 127 Vac)	500mA (-hp- Part Number 2110-0012)	Gray 2110-0565
230Vac Nominal (196-254 Vac)	250mA (-hp- Part Number 2110-0489)	Black 2110-0567

The power line fuse is located on the rear panel of the 3488A in the lower right hand corner. To install or replace the fuse, turn the instrument off and remove the power cord from the rear of the instrument. With a small flatblade screwdriver rotate the fuse cap counterclockwise. Remove the fuse cap and replace the fuse with the appropriate type (see Figure 5-1). Reinstall the fuse cap and apply power.

Grounding Requirements

The 3488A is equipped with a three-conductor ac power cable. The power cable must either be plugged into an approved three-contact electrical outlet or used with a three-contact to two-contact adapter with the grounding wire (green) firmly connected to an electrical ground (safety ground). The 3488A's power jack and supplied power cable meet IEC (International Safety Commission) safety standards. A ground lug is mounted on the rear panel and is to be connected to a reliable earth ground when the power cord ground is unavailable.

Power Cords and Receptacles

Figure 5-2 shows the various power cord configurations that are available to provide power to the 3488A. The -hp- part number shown directly below the individual power plug drawing is the part number for the power cord complete with plug. If the appropriate power cord is not included with the instrument, notify the nearest -hp- Sales and Service Office.

<p>250 V OPERATION</p>  <p>PLUG*: CEE7-V11 CABLE*: HP 8120-1692</p>	<p>250 V OPERATION</p>  <p>PLUG*: CEE22-V1 CABLE*: HP 8120-1880</p>	<p>250 V OPERATION</p>  <p>PLUG*: DHCR 107 CABLE*: HP 8120-2956</p>	<p>250 V OPERATION</p>  <p>PLUG*: SEV 1011.1959-24507 TYPE 12 CABLE*: HP 8120-2104</p>	
<p>125 V - 6A**</p>  <p>PLUG*: NEMA 1-15P CABLE*: HP 8120-0684</p>	<p>250 V OPERATION</p>  <p>PLUG*: NZSS 198/AS C112 CABLE*: HP 8120-0896</p>	<p>250 V OPERATION</p>  <p>PLUG*: BS 1363A CABLE*: HP 8120-1703</p>	<p>250 V - 6A**</p>  <p>PLUG*: NEMA G-15P CABLE*: HP 8120-0698</p>	<p>125 V - 6A**</p>  <p>PLUG*: NEMA 5-15P CABLE*: HP 8120-1521</p>
<p>STD-B-4195 (Rev.)</p> <p>*The number shown for the plug is the industry identifier for the plug only. The number shown for the cable is an HP part number for a complete cable including the plug. **UL listed for use in the United States of America</p>				

Figure 5-2. Power Cords

Instrument Mounting

The 3488A is equipped with feet and tilt stand in place, ready for use as a bench instrument. The front of the instrument may be elevated for convenience of operating

and viewing by extending the tilt stand. The instrument can also be mounted in a standard 19" rack with the optional rack mounting kits. See Table 5-1.

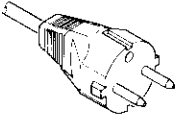
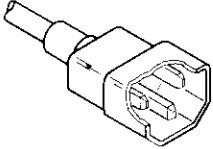
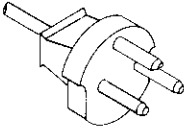
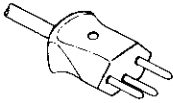
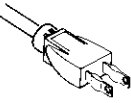
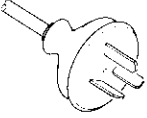
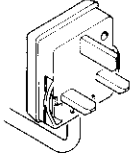
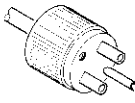
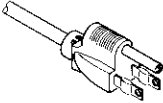
HP-IB Interface Connections

HP-IB (Hewlett-Packard Interface Bus) is Hewlett-Packard's implementation of IEEE Standard 488-1978, Standard Digital Interface for Programmable Instrumentation. Refer to Appendix B for more detailed information on HP-IB.

The 3488A's HP-IB connection is made by an HP-IB interface cable to the 24 pin HP-IB connector on the rear panel of the instrument. A typical interconnection of HP-IB compatible instruments is shown in Figure 5-3.

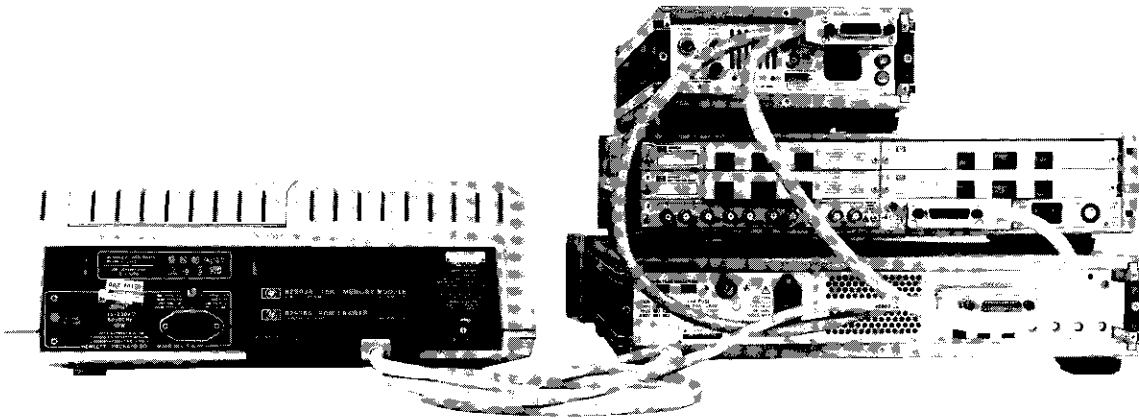

Figure 5-3. Typical HP-IB System Interconnection

A total of 15 HP-IB compatible instruments can be connected together by the same interface bus. Cables used with the interface bus have single male-female connectors at each end so that several cables can be stacked, thus allowing more than one cable to be attached to any instrument.

For best HP-IB performance, total HP-IB cable length for the system must not exceed 2 metres (6.5 feet) times the total number of instruments to be connected or 20 metres (65 feet), whichever is less.

HP-IB Address Selection

The HP-IB address of the 3488A is determined by the setting of five switches on the rear panel. These switches are read when the 3488A is turned on or reset. Normally, the 3488A leaves the factory with the address switches set to decimal "09". The corresponding ASCII code is a listen address of ")" and a talk address of "I". Refer to Figure 5-4 for other HP-IB address codes. The factory setting of the Power-on SRQ switch is off.

3488A Switch/Control Unit

Shown at Factory Default Address (09). This number is called the Primary Address.

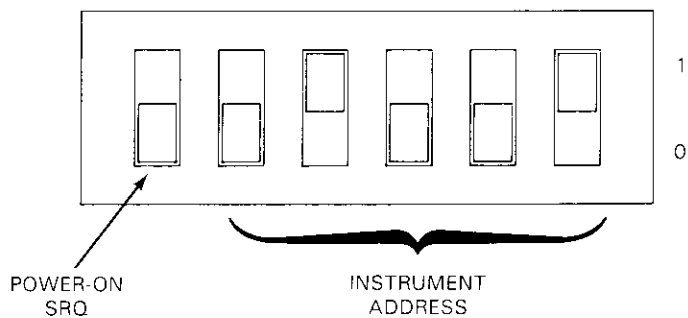

ASCII Code Character		Address Switches					5-bit
Listen	Talk	A4	A5	A6	A7	A8	Decimal Code
SP	@	0	0	0	0	0	00
!	A	0	0	0	0	1	01
"	B	0	0	0	1	0	02
..#	C	0	0	0	1	1	03
\$	D	0	0	1	0	0	04
--%	E	0	0	1	0	1	05
&	F	0	0	1	1	0	06
'	G	0	0	1	1	1	07
(H	0	1	0	0	0	08
*	I	0	1	0	0	1	09 ← Factory Default
+	J	0	1	0	1	0	10
,	K	0	1	0	1	1	11
.	L	0	1	1	0	0	12
.	M	0	1	1	0	1	13
/	N	0	1	1	1	0	14
/	O	0	1	1	1	1	15
0	P	1	0	0	0	0	16
1	Q	1	0	0	0	1	17
2	R	1	0	0	1	0	18
3	S	1	0	0	1	1	19
4	T	1	0	1	0	0	20
5	U	1	0	1	0	1	21
6	V	1	0	1	1	0	22
7	W	1	0	1	1	1	23
8	X	1	1	0	0	0	24
9	Y	1	1	0	0	1	25
:	Z	1	1	0	1	0	26
:	[1	1	0	1	1	27
<		1	1	1	0	0	28
=	J	1	1	1	0	1	29
>	~	1	1	1	1	0	30
Talk Only		1	1	1	1	1	

Select Codes can be any integer 1 thru 12. Primary Addresses can be any integer 0 thru 30. 31 is not a valid HP-IB address.

Figure 5-4. 3488A HP-IB Address Codes

Options and Accessories

Table 5-1 lists the available accessories and options for your 3488A. These accessories are offered to help you maximize the useability and convenience of your 3488A.

Table 5-1. Accessories

Description of Option/Accessory	Use this number when ordering with 3488A	Use this number when ordering separately
10 Channel Relay Multiplexer Option with terminal connector	Option 010	44470A
Extra terminal connector block for 44470A	44480A	44480A
10 Channel General Purpose Relay Option with terminal connector	Option 011	44471A
Extra terminal connector block for 44471A	44481A	44481A
Dual 4 channel VHF switch Option	Option 012	44472A
4X4 Matrix Switch Option with terminal connector	Option 013	44473A
Extra terminal connector block for 44473A	44483A	44483A
16 Bit Digital I/O	Option 014	44474A
Extra terminal connector block for 44474A	44484A	44484A
Breadboard	Option 015	44475A
Extra terminal connector block for 44475A	44485A	44485A
Side Handle Kit	Option 401	5061-1171
Front Handle Kit	Option 907	5061-1170
Rack Mount Kit	Option 908	5061-1168
Rack Mount Kit with Front Handle	Option 909	5061-1169
Additional set of 3488A Documentation	Option 910	Order by part number:
1 Metre HP-IB Cable	10833A	10833A
2 Metre HP-IB Cable	10833B	10833B
4 Metre HP-IB Cable	10833C	10833C
0.5 Metre HP-IB Cable	10833D	10833D
23 cm (9 in) BNC-BNC Cable	10502A	10502A
122 cm (48 in) BNC-BNC	10503A	10503A
Dual Banana Plug (no cable)	1251-2816	1251-2816
BNC Tee (male-female-female)	1250-0781	1250-0781

Warranty Information

Certification

Hewlett-Packard Company certifies that this product met its published specifications at the time of shipment from the factory. Hewlett-Packard further certifies that its calibration measurements are traceable to the United States National Bureau of Standards, to the extent allowed by the bureau's calibration facility, and to the calibration facilities of other International Standards Organization members.

Warranty

This Hewlett-Packard product is warranted against defects in material and workmanship for a period of one year from the date of shipment. During the warranty period, Hewlett-Packard will, at its option, either repair or replace products which prove to be defective.

For warranty or service repair, this product must be returned to a service facility designated by -hp-. Buyer shall prepay shipping charges to -hp- and -hp- shall pay shipping charges to return the product to Buyer. However, Buyer shall pay all shipping charges, duties, and taxes for products returned to -hp- from another country.

Duration and conditions of warranty for this instrument may be superceded when instrument is integrated into (becomes part of) other -hp- products.

Hewlett-Packard warrants that its software and firmware designated by -hp- for use with an instrument will execute its programming instructions when properly installed on that instrument. Hewlett-Packard does not warrant that the operation of the instrument, or software, or firmware will be uninterrupted or error free.

Limitation of Warranty

The foregoing warranty shall not apply to defects resulting from improper or inadequate maintenance by Buyer, Buyer-supplied software or interfacing, unauthorized modification or misuse, or improper site preparation or maintenance.

NO OTHER WARRANTY IS EXPRESSED OR IMPLIED. HEWLETT-PACKARD SPECIFICALLY DISCLAIMS THE IMPLIED WARRANTIES OF MERCHANTABILITY AND FITNESS FOR A PARTICULAR PURPOSE.

Exclusive Remedies

THE REMEDIES PROVIDED HEREIN ARE BUYERS SOLE AND EXCLUSIVE REMEDIES. HEWLETT-PACKARD SHALL NOT BE LIABLE FOR ANY DIRECT, INDIRECT, SPECIAL, INCIDENTAL, OR CONSEQUENTIAL DAMAGES, WHETHER BASED ON CONTRACT, TORT, OR OTHER LEGAL THEORY.

Assistance

Product maintenance agreements and other customer assistance agreements are available for Hewlett-Packard customers.

For any assistance, contact your nearest Hewlett-Packard Sales and Service Office. Addresses are provided in the back of this manual.

In addition to the above warranty, the following LIMITATION OF WARRANTY applies to the option 015, Breadboard assembly.

Limitation of Warranty for Option 015

The foregoing warranty shall not apply to defects resulting from improper or inadequate maintenance by Buyer. Buyer supplied software or interfacing, unauthorized modification or misuse, operation outside of the environmental specifications for the product, or improper site preparation or maintenance.

The design and implementation of any circuit used on this product is solely the responsibility of the Buyer. Hewlett-Packard Company does not warrant the Buyers circuitry or malfunctions of the 3488A or plug-in options that result from the Buyers circuitry. In addition, -hp- does not warrant any damage that occurs as a result of the Buyers circuit, including but not limited to the following:

1. Analog and digital sections are interconnected.
2. 3488A power supply limitations are exceeded.
3. Component height/protrusions restrictions are exceeded.
4. Maximum input voltage on the digital lines is exceeded.

Safety Summary

General safety precautions must be adhered to during all phases of operation of the 3488A. Failure to comply with these precautions or with specific warnings elsewhere in this manual violates safety standards of design manufacture, and intended use of the instrument. The Hewlett-Packard Company assumes no liability for the customer's failure to comply with these requirements.

Operating personnel must not remove instrument covers. Component replacement must be made by qualified service-trained personnel with a knowledge of the hazards involved. Under certain conditions, dangerous voltages may exist even with the power cable removed. To avoid injuries, always disconnect power and discharge circuits before touching them.

Do not operate the instrument in the presence of flammable gases or fumes. Operation of any electrical instrument in such an environment constitutes a definite safety hazard.

Warnings and Cautions precede potentially dangerous procedures throughout this manual. Instructions contained in the warnings and cautions must be followed. Safety symbols used on the instrument or in the manual include the following:

WARNING The **WARNING** sign denotes a hazard. It calls attention to a procedure, practice, condition, or the like, which, if not correctly performed or adhered to, could result in injury or death to personnel.

CAUTION The **CAUTION** sign denotes a hazard. It calls attention to an operating procedure, practice, condition, or the like, which, if not correctly performed or adhered to, could result in damage to all or part of the product.

NOTE The **NOTE** sign denotes important information. It calls attention to a procedure, practice, condition, or the like which is essential to highlight.



INSTRUCTION MANUAL SYMBOL. The product will be marked with this symbol when it is necessary for the user to refer to the instruction manual in order to protect against damage to the instrument.



Indicates dangerous voltage (terminal fed from the interior by voltages exceeding 1000 volts must be so marked in red).



Alternating Voltage/Current



Direct Voltage/Current.



This instrument or option assembly contains static sensitive devices. Use anti-static handling procedures to prevent electrostatic discharge.

DO NOT OPERATE A DAMAGED INSTRUMENT

Whenever it is possible that the safety protection features built into this instrument have been impaired, either through physical damage, excessive moisture, or any other reason, REMOVE POWER and do not use the instrument until safe operation can be verified by service-trained personnel. If necessary, return the instrument to a Hewlett-Packard Sales and Service Office for service and repair to ensure that safety features are maintained.

Specifications

The specifications for the 3488A are the performance characteristics of the instrument which are certified. These specifications are listed at the end of this chapter, and are the performance standards or limits against which the instrument is tested. Included in the table are some supplemental characteristics of the 3488A. These should be considered as additional and general information for you, the user. Because of the many operating capabilities of the 3488A, exercise care when checking the instrument specifications.

Any changes in specifications due to manufacturing changes, design, or traceability to the National Bureau of Standards will be covered in a manual design change supplement.

Environmental Requirements

The 3488A should not be operated outside the ambient temperature range of 0°C to 55°C (32°F to 131°F) or stored outside the ambient temperature range of -40°C to +75°C (-40°F to +167°F).

WARNING

If any of the following symptoms exist, or are even suspected, remove the instrument from service. Do not use the instrument until safe operation can be verified by service-trained personnel.

- 1. Visible damage.*
- 2. Severe transport stress.*
- 3. Prolonged storage under adverse conditions.*
- 4. Failure to perform intended measurements or functions.*

If necessary, return the instrument to a Hewlett-Packard Sales and Service Office for service and repair to ensure that safety features are maintained.

Miscellaneous

How to Obtain Repair Service

You may have your 3488A repaired at an -hp- service center at anytime, whether it is under warranty or not. There is a charge for repairs after the one year warranty period. Contact you local Sales and Service office for shipping instructions prior to returning the instrument. A list of Sales and Service Offices is located in the back of this manual.

3488A Serial Number

Each 3488A has a serial number printed on a plate on the bottom cover. This serial number has the form XXXXAYYYYY where the XXXX is the serial prefix, A is the country of origin (A – USA) and YYYYY is the serial suffix.

We recommend that owners keep a separate record of this serial number. Should your instrument be lost or stolen, the complete serial number is often necessary for tracing and recovery, as well as for insurance claims.

In addition, each 3488A option assembly will have a Warranty Datecode label and an Electrical Revision Code label permanently applied to the circuit board. These numbers should also be recorded. Any communication with -hp- about the options should include these numbers.

General Shipping Instructions

Should you ever need to ship your 3488A, remove all option assemblies from the mainframe. Use clean handling and anti-static techniques when removing and packaging the option assemblies. **WRAP THE OPTIONS IN ANTI-STATIC BAGS.** Be certain that the mainframe and each option is packaged in a protective package (use the original shipping container and cushioning material) to avoid transit damage. Such damage is not covered by the warranty.

Attach a tag to the instrument identifying the owner and indicating the service or repair needed. Include the model number and serial number of the instrument and/or option cards. In any correspondence, identify the instrument by model and full serial number. We suggest that you always insure shipments.

Cleaning

Disconnect the 3488A from its power source before cleaning. Also, remove sources of power from the option assemblies. The instrument can be cleaned with a soft

cloth dampened either in clean water or in water containing a mild detergent. Do not use an excessively wet cloth or allow water inside the instrument. Do not use any abrasive cleaners, especially on the display. Do not press hard on the display.

WARNING

The 3488A uses latching relays on the 44470A, 44471A, 44472A, and 44473A Option assemblies. The state of these relays can only be altered under front panel or program control. This is an advantage in the sense that, under most conditions of failure, the relays will remain in whatever state your program has set them. However, in case of power or equipment failure, any application requiring a failsafe method of insuring that the circuits under control are in a known state must be provided by the installer.

In case of component failure or programming error, any voltage input to an option card may be present on any other terminal on the same option card.

Table 5-2. 3488A General Specifications

ENVIRONMENTAL

Operating: 0 - 55°C (32 - 130°F);
Storage: - 40 - 75°C (-40 - 165°F);
Humidity: 95%, 0 - 40°C (32 - 104°F)

POWER

Line Voltage (Mains): 86-132V (115V) or 195-250V (230V) switch selectable, 48 - 440 Hz. Fused at 0.5A (115V) or 0.25A (230V).

Consumption: 6 VA (mainframe); 18 VA (maximum).

SIZE

89mm H (without removable feet) x 425mm W x 292mm D (3.5'' x 16.75'' x 11.5'').
 Height (with removable feet): 100mm (4'').
 Allow 76mm (3'') additional depth for wiring.

WEIGHT

	Net		Shipping	
	kg.	lbs.	kg.	lbs.
3488A mainframe—	5.0	11.0	8.5	19.0
Modules (ea.)—	0.7	1.5	1.5	3.5
Maximum Total—	8.5	18.5	16.0	36.5

HP-IB (IEEE-488) Capabilities:

SH1 AH1 T6 TE0 L4 LE0 SR1 RL1 PPO DC1 DT1 E2

Chapter 6

44470A

Relay Multiplexer

Introduction

-hp- Model 44470A (3488A Option 010) Relay Multiplexer provides 10 channels of 2 wires each to switch analog signals to a common bus. The relays exhibit low thermal offset characteristics making them ideal for precision low level measurements*.

The individual relays on this option are rated at 250 Volts @ 2 Amps and can be operated in either a BBM mode (break before make) or in a mode where multiple channels may be closed together. This multiplexer option offers many possible uses including multiplexing signals directly to a measuring instrument or as an Input/Output multiplexer with the 44473A Matrix option. A removable terminal block assembly is provided for convenience in wiring and also provides strain relief for cables.

This chapter is designed to serve as a reference guide for using the 44470A Relay Multiplexer. As such, it contains programming information, installation and configuration information, and application examples.

WARNING

The 3488A Option 010, 44470A Multiplexer Assembly uses latching relays. The state of these relays can only be altered under program control. This is an advantage in the sense that, under most conditions of failure, the relays will remain in whatever state your program has set them. However, in case of power or equipment failure, any application requiring a failsafe method of insuring that the circuits under control are in a known state must be provided by the installer.

Operation

As shown in Figure 6-1, the 44470A Relay Multiplexer assembly consists of ten 2-wire relays connected to a common analog bus. Two modes of operation are possible: single channel, break-before-make or multiple channels closed together. Basically, there are two different ways the 44470A may be used: inputs from 10 different sources may be switched to the one common bus or one input (common bus) may be switched to 10 different places.

* Although the 44470 Multiplexer can be used to switch thermocouples, there is no offset compensation built-in and errors may occur.

An example of the first case would be when measuring up to 10 different voltage sources. Each channel connects to one voltage source and the common bus would connect to a digital voltmeter. As each relay is closed, the voltmeter measures that voltage. In this case only one relay would be closed at any one time.

To illustrate the second case, consider a dc voltage source being switched to several different loads. More than one relay might be closed at any one time.

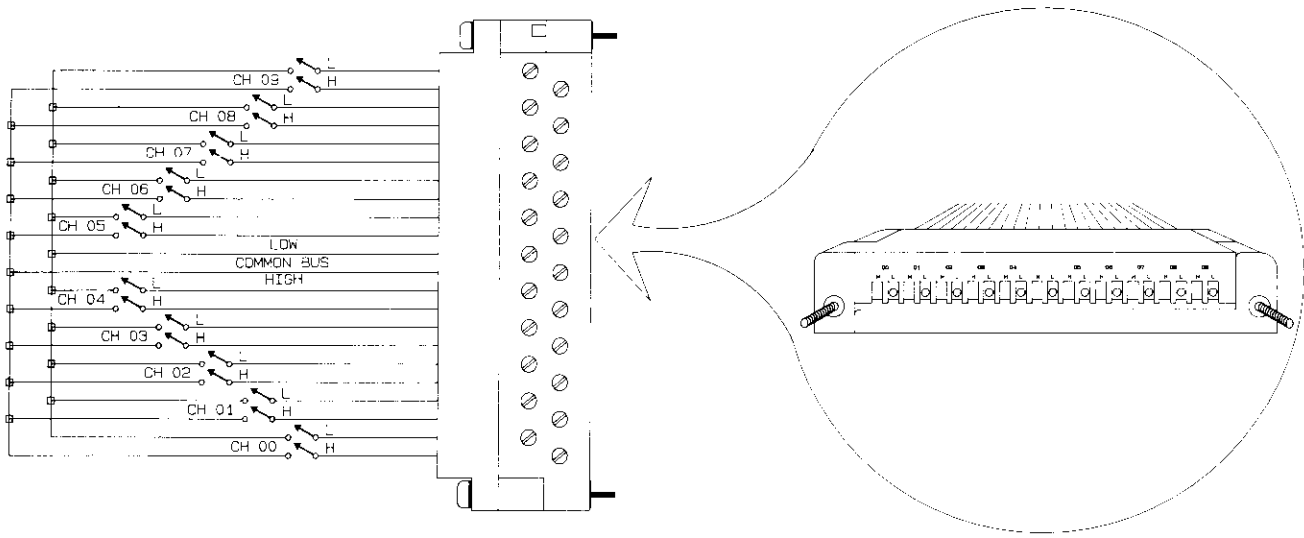

3488-1-1

Figure 6-1. 44470A Simplified Schematic

At turn on or reset (either from the front panel RESET key or the HP-IB CLEAR command), all channels on the 44470A will be opened.

Channels

A channel, as described in Chapter 2, refers to an individual relay, in this case a relay on the 44470A assembly. Therefore, when speaking of closing a channel, we are referring to closing a particular relay. Channel numbers are two digit numbers 00 through 09 and are repeated on each 44470A assembly. This can be seen by the numbering on the Terminal Block Edge Connector.

Channel addresses, on the other hand, are determined by which slot the 44470A assembly is mounted in. Channel addresses are a three digit number where the first digit specifies the particular slot where the 44470A option is installed. The last two digits are the channel number. For example, channel address 102 means slot number 1, channel 02.

The following table shows the channel addressing scheme for the five different slots.

Table 6-1. Channel Addressing Scheme

Channel number as shown on the terminal block	Channel address if 44470A assembly is in slot number:				
	Slot 1	Slot 2	Slot 3	Slot 4	Slot 5
00	100	200	300	400	500
01	101	201	301	401	501
02	102	202	302	402	502
03	103	203	303	403	503
04	104	204	304	404	504
05	105	205	305	405	505
06	106	206	306	406	506
07	107	207	307	407	507
08	108	208	308	408	508
09	109	209	309	409	509

Commands

Most of the 3488A commands can be used in controlling the 44470A option. In addition to the standard 3488A commands, two HP-IB interface commands directly effect the 44470A. All of these commands are described using a simple format of explanation.

In the following summary of command descriptions, square brackets ([]) indicate optional parameters, whereas items in <> brackets are mandatory. For further explanation of the command code mnemonics, refer to Chapters 2 and 3.

CLOSE a channel

Command Format: CLOSE <ch. address>[,<ch. address>,<ch. address>,....]

Description

The CLOSE command is used to simply close one or more channels on the 44470A. Note that the CLOSE command does not open any channels that were previously closed. Several channels can be closed with one CLOSE command by separating the channel addresses with a comma. If more than one channel is specified with the command, they are closed in the order listed.

Examples

OUTPUT 709;"CLOSE 102,103,105" ! Closes channels 2, 3, and 5 in slot number 1

OUTPUT 709;"CLOSE 104,305" ! Closes channel number 4 in slot 1 and channel number 5 in slot 3.

OPEN a channel

Command Format: OPEN <ch. address>[,<ch. address>,<ch.address>...]

Description

OPEN is used to open individual channels on the 44470A assembly. If more than one channel is specified in the OPEN list, they are opened in the order listed. Use the CARD RESET command to open all channels on an assembly. It is easier than listing each channel individually.

Example

```
OUTPUT 709;"OPEN 103,105,107"    ! 1 Relays 3, 5, and 7 are opened in slot
                                   number 1
```

VIEW a channel

Command Format: VIEW <ch. address>

Description

The VIEW command is used to look at the state (either open or closed) of a particular channel. The 3488A responds with the string "OPEN 1" if the specified channel is open. If the specified channel is closed, the 3488A responds with the string "CLOSED 0". In the 3488A display, the channel address is displayed followed by a colon and the appropriate string.

Example

```
10 OUTPUT 709;"VIEW 105"    ! VIEWs channel 5 on slot number 1
20 ENTER 709;A$             ! input the response from the 3488A
30 DISP A$                  ! A$ will either be "OPEN 1" or "CLOSED 0"
```

OR

```
20 ENTER 709; A
30 DISP A                    ! "A" will either be 1 or 0 (open or closed,
                               respectively)
```

CARD TYPE

Command Format: CTYPE <slot>

Description

This command causes the 3488A to respond with a description of what type of option card is located in the specified slot. The description includes the name of the card as well as the option number. In the display, the description is preceded by the specified slot number.

Card Type	Description
Slot is empty	NO CARD 00000
10 Channel Multiplexer	RELAY MUX 44470
General Purpose Card	GP RELAY 44471
High Frequency Scanner	VHF SW 44472
Matrix Card	MATRIX SW 44473
Digital I/O Card	DIGITAL IO 44474
Breadboard Card	BREADBOARD 44475

Example

```
10 OUTPUT 709;"CTYPE 3"      ! look for the card in slot 3
20 ENTER 709;A$
30 DISP A$                    ! Card description will be displayed
```

CARD RESET

Command Format: CRESET <slot>[,<slot>,...]

Description

CRESET is used to reset all channels on the 44470A assembly to their open state. Only cards in the slots specified are affected.

Example

```
OUTPUT 709;"CRESET 2"      ! resets the option assembly in slot 2
```

CARD PAIR

Command Format: CPAIR <slot>,<slot>

Description

Card PAIR is used to pair up two option assemblies of the same type, e.g., 44470A's. This operation will effectively assign both options to both slot numbers so that closing or opening a channel on either option will perform the same operation on the respective channel on the other option. This feature is especially useful when doing 4-wire scanning.

Commands used with the Card PAIR function are: CLOSE, OPEN, CRESET, CHAN and STEP. Of course, paired slots can be used as part of a scan list.

Executing a CPAIR command cancels any previous CPAIR command that involved either of the two options. It is possible, however, to have two sets of card pairs, e.g. slots 1 paired with 2 and 3 paired with 4.

Example

OUTPUT 709;"CPAIR 1,3" ! sets the options in slots 1 and 3 as pairs

OUTPUT 709;"CLOSE 105" ! closes channels 105 and 305 simultaneously

Executing the CPAIR command without specifying slot numbers allows you to determine which, if any, slots are paired together. Four numbers are returned separated by commas. The first two numbers specify slots in the first pair, the second two numbers specify the second pair. An inactive card pair is denoted by 0,0.

Example

OUTPUT 709; "CPAIR"

ENTER 709; A\$

DISP A\$

String variable A\$ will have the four slot numbers.

Note, you may have to dimension A\$ to 30.

At the back of this chapter is a section on applications. One of the application examples demonstrates the use of the CPAIR mode with 4-wire resistance measurements.

SCAN LIST

Command Format: SLIST [<ch. address>(, or -)<ch.address> . . . <ch. address>]

Description

Scan List allows you to specify a sequence of channels to be scanned. The sequence is specified as a list of up to 85 channel addresses (relay or digital I/O lines) and/or stored setups separated by commas. Contiguous channels may be specified by entering the first channel address and the last channel address separated by a hyphen. STEP is used to sequentially close channels in the list.

Example

```
10 OUTPUT 709; "SLIST 104,205,300-309,410,0"  
20 FOR I=1 TO 14  
30 OUTPUT 709; "STEP"  
40 NEXT I
```

In this example, the scan would start with channel 104, followed by channel 205, followed by channels 300, 301, 302, . . . 309 and finally channel 410. The 0 channel specified at the end of the list is a stop channel and opens the last channel closed (channel 410) but does not close any other channel.

Notes

1. Channels may be scanned in any sequence, i.e., 309-300.
2. Stepping beyond the last channel specified in the Scan List causes a wrap-around to the first channel in the list. The number 0 can be used as a stop channel.
3. Refer to the Advanced Operations section in this chapter for information on using the External Increment and Channel Closed features.
4. The commands OPEN, CLOSE, CRESET, or RECALL will have no effect on the Scan List even though the state of individual channels may change.
5. Stored setups may be recalled as part of the Scan List simply by specifying the register number. For example: SLIST 104,105,106,25,200,201. Here, register 25 has the stored setup.

STEPping Through the Scan List

Command Format: STEP

Description

STEP is used to open the the last channel closed and close the next channel in the Scan List. If STEP is executed and no Scan List exists, the 3488A will generate an execution error.

The 3488A uses a pointer to keep track of which channel in the Scan List is currently closed. When STEP is executed, that channel is opened and the next item in the list is checked. If the next item in the list is a relay or Digital I/O line, that channel is closed. If the next item in the list is a stored setup, that setup is recalled. Channels that are closed by a setup will remain closed, that is, they are not opened by the next execution of the STEP command.

For additional information see the Advanced Operation section of this chapter for Channel Closed and External Increment.

Example

```
10 OUTPUT 709;"SLIST 100 – 109;CMON 1"  
20 FOR I= 1 TO 10  
30 OUTPUT 709;"STEP"  
40 NEXT I
```

CHANnel command

Command Format: CHAN [<ch. address>]

Description

CHAN is used to open the last channel closed by either STEP or CHAN and close the specified channel. If no channel is specified with CHAN, the 3488A will respond with the number of the last channel closed by either STEP or CHAN. If no channel has been closed since the last reset, then CHAN returns the number 0.

If a Scan List is in effect when CHAN is executed, the 3488A will search through the list and position the Scan List pointer to the channel specified by CHAN. If CHAN specifies a channel that is not in the Scan List, and then STEP is executed, the 3488A will open the channel closed by CHAN and go to the beginning of the Scan List.

Example

OUTPUT 709; "CHAN 203" ! Closes channel 203

OUTPUT 709; "CHAN"

ENTER 709; A

DISP A ! Variable A will contain the last channel closed, i.e.,
203

CARD MONITOR mode

Command Format: CMON <slot>

Description

Card Monitor is used to look at the state of the individual option assemblies in the specified slot (1-5). Specifying 0 as the slot will cause the monitor mode to be cancelled. If a negative number is used for the slot, the 3488A will go to its monitor tracking mode.

When used to monitor the 44470A assembly, the display shows the slot number (extreme left) and those channels that are closed, separated by commas. The MONitor annunciator also comes on:

Example

OUTPUT 709;"CLOSE 103,105,107; CMON 1"

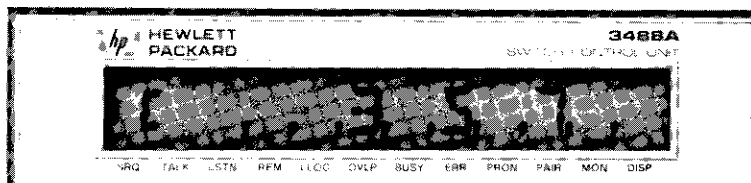

The format of the display can be summarized as:

s: n,n,n,n,n,n,n,n,n

where s represents the slot number being monitored and n is a one digit channel number.

Advanced Operations

Advanced Operations provide you with more capabilities when using the 3488A. It may be important, for example, to tell the system voltmeter when a channel has been closed and thus take a measurement. Or maybe you need to close the next channel in a scan list when some external event has taken place, perhaps as soon as the voltmeter has completed its reading. Most operations can be performed with only the basic commands, but for those times when you need something more, the advanced operations should meet your switching needs.

External Increment and Channel Closed

External Increment (EI) provides a method of sequencing through a scan list without system computer intervention. Typically, EI is connected to the Voltmeter Complete* output on a system voltmeter. Thus, when the voltmeter has completed its measurement, it signals the 3488A to step to the next channel in the list. The EI input is rising-edge triggered and TTL compatible.

Channel Closed (CC) provides a 15 μ S TTL pulse for signaling when a channel has been closed in the 3488A. This signal can be tied to the External Trigger input of a voltmeter to trigger it when a channel is closed. Together, EI and CC can be used with a system voltmeter to sequence through a scan list without any intervention by the system computer. Later in this chapter, examples number 2 and 3 will show how this can be done.

Using the External Increment and Channel closed features requires the use of a 44474A Digital I/O option. This also means that the Digital I/O option cannot be configured in Handshake Mode #5 when it is used for scanning (it can be used statically, however). The DMODE command is used to specify the handshake mode, Polarity, and External Increment (EI). Only one Digital I/O option can be configured for EI at a time. If one option is configured to accept EI and another is subsequently enabled, the first card will be disabled.

Even though the only specifier we are interested in is EI, the mode and polarity specifiers must be included. The format for specifying DMODE is as follows:

```
DMODE <slot> [, <mode> ] [, <polarity> ] [, <EI> ]
```

* Voltmeter Complete is a feature on most Hewlett-Packard digital voltmeters to signal the completion of a measurement by means of a TTL compatible pulse.

The MODE specifier is as follows:

Definition	Value
Static Mode	1
Static mode for read back	2
R/W and Strobe	3
Rd & Wrt Strobe	4
Handshake (no EI)	5

Any of the modes may be specified for use with External Increment except the Handshake mode (value 5).

The Polarity specifier is the sum of weighted values and is defined as follows:

Definition	Value
Lower 8-bits polarity	1 = Low true
Upper 8-bits polarity	2 = Low true
PCTL Polarity	4 = Low busy
PFLG Polarity	8 = Low busy
I/O Direction line polarity	16 = Low input mode

EI is enabled by specifying 1. It is disabled with a specifier of 0.

Refer to Chapter 10 for more information on setting up the 44474A Digital I/O option for External Increment and Channel Closed.

Delay

Command Format: DELAY [<time in mS>]

Description

The DELAY command is used to insert a time delay between the time that a channel is closed and the time that the next command can be executed and the Channel Closed pulse is output. The delay time may be specified from 0 to 32,767 mS (32 seconds) in 1 mS increments. The delay time does not become effective until either CHAN or STEP is executed.

If any command is sent to the 3488A during the delay time, the command will be executed as soon as the delay time is complete. If there is not a time value sent with the DELAY command, the 3488A will respond with the current value of the delay time.

Remember that the Channel Closed pulse will be output from whichever 44474A assembly has External Increment enabled.

Examples

OUTPUT 709; "DELAY 2000; CHAN 101" ! The delay time is 2000 mS = 2 seconds

OUTPUT 709; "DELAY"

ENTER 709; A

DISP A

! Display the delay time

HP-IB Interface Commands

Only two interface commands affect the state of the 44470A channels: TRIGGER (Group Execute Trigger) and CLEAR (Device Clear or Selected Device Clear). TRIGGER performs the same function as the 3488A STEP command. In other words, the two commands:

TRIGGER 7 (or TRIGGER 709)

and

OUTPUT 709; "STEP"

perform the same function as far as the 44470A assembly is concerned.

CLEAR, whether a Device Clear or Selected Device Clear, simply resets the 3488A and hence all relays will go to their open state.

44470A Assembly Installation

This portion of the chapter is written specifically for the service trained technician. It provides the necessary information for a person trained in electronic circuitry to configure and install the option assembly. Carefully read through this section and adhere to all cautions and warnings.

WARNING

Only qualified service trained personnel should remove, configure, or install the 3488A option assemblies. Disconnect the 3488A power cord from the back of the instrument prior to installing the option assemblies.

WARNING

The 3488A Option 010,44470A Relay Multiplexer, uses latching relays. The state of these relays can only be altered under program control. This is an advantage in the sense that, under most conditions of failure, the relays will remain in whatever state your program has set them. However, in case of power or equipment failure, any application requiring a failsafe method of insuring that the circuits under control are in a known state must be provided by the installer.

In case of component failure or programming error, any voltage input to an option card may be present on any other terminal on the same option card.

When you initially received your 3488A, the option assemblies were not installed in the mainframe. Each option assembly was packaged separately along with a terminal block edge connector and a two piece strain relief housing. In addition, two labels were provided for option identification.

CAUTION

Use clean handling and anti-static procedures when removing, configuring and installing the option assemblies. The circuit boards must be kept clean to ensure compliance with impedance specifications. The option assemblies as well as the 3488A mainframe contains CMOS devices which are susceptible to static discharges.

A few simple steps are required to install the 44470A assembly. Carefully observe the orientation of the assembly and terminal block as you install them.

1. Pre-installation
 - a. Remove the ac power cord from the 3488A before installing any option assembly.
 - b. Position the 3488A with the rear panel towards you.
 - c. Select a slot. Refer to Figure 6-2, the 3488A has five slots for installing option assemblies. The 44470A can be used in any of the five slots.

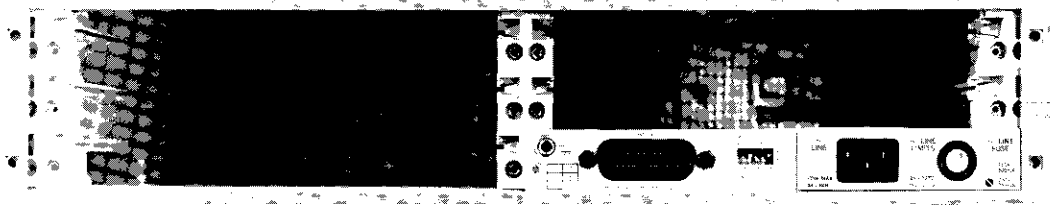

Figure 6-2. Rear Panel View Of The 3488A

2. Option assembly installation

- a. Hold the option assembly, component side down, by the metal shields. Insert the circuit card into the slot guides and slide toward the front of the instrument. Push firmly until the assembly 'snaps' into place. Fold the plastic levers toward the assembly. These levers lock the option into the mainframe.

NOTE

To remove the option assembly, simply unfold the plastic tab levers. This will release the locking mechanism and pull the option out of the mainframe connector.

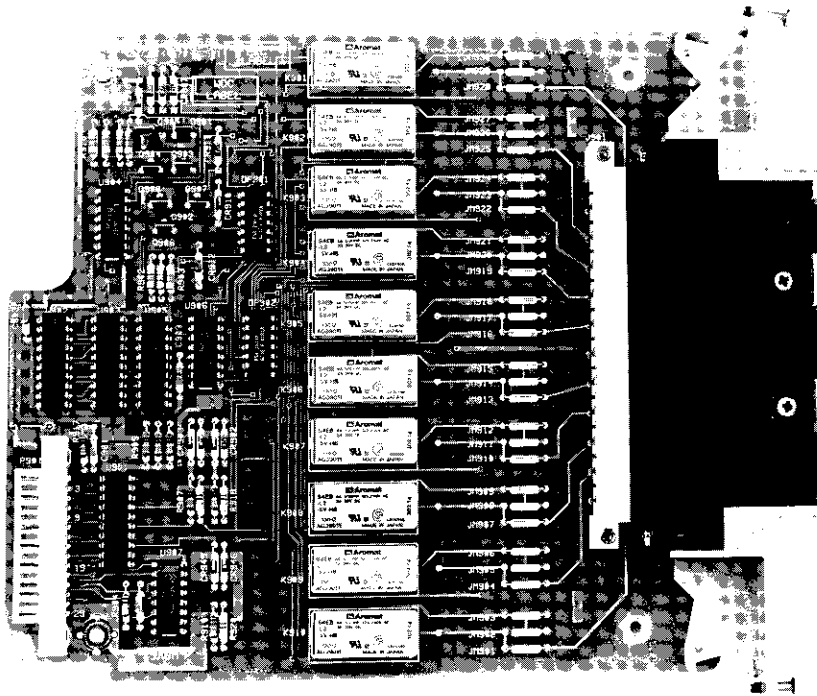

Figure 6-3. Option Card

3. Terminal Block Wiring

a. Wire the Terminal Block Edge Connector. The following photograph shows the channel connection sequence for the 44470A Terminal Block Edge Connector. This terminal block is keyed to fit only the 44470A assembly. Extra terminal blocks are available under the -hp- part number 44480A. This terminal block was designed to accept wires in the range of 18 to 26 AWG.



Figure 6-4. Terminal Block

4. Strain Relief

a. Secure the terminal block to the strain relief housing with the captive screws on the terminal block. Make certain that the screws used to tighten the connector wires to the terminal block are accessible through the strain relief housing.

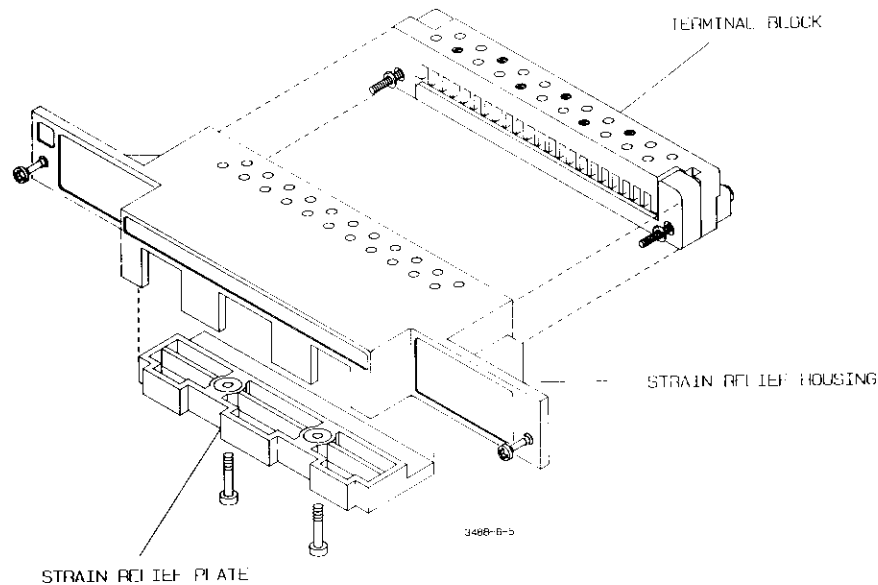

Figure 6-5. Strain Relief Housing

b. Route the wires evenly through the three strain relief cutouts. This will ensure a uniform amount of strain relief. If only a few wires are used, they should go through the middle cutout.

c. To protect wires smaller than 22AWG it is recommended that these wires be bundled together starting no more than 4" from the back of the 3488A. Failure to do so may cause wires to break at the strain relief. To illustrate the need for this, a 26AWG wire can survive about 7 to 8 pounds of tension before breaking. A bundle of 10, however, could survive up to 70 pounds of tension.



Figure 6-6. Cable Routing

- d. Secure the strain relief plate to the strain relief housing (ribbed side down). Do not over tighten the screws.
- e. Push the terminal block with strain relief housing onto the option assembly connector. Tighten the two screws on either end of the housing.

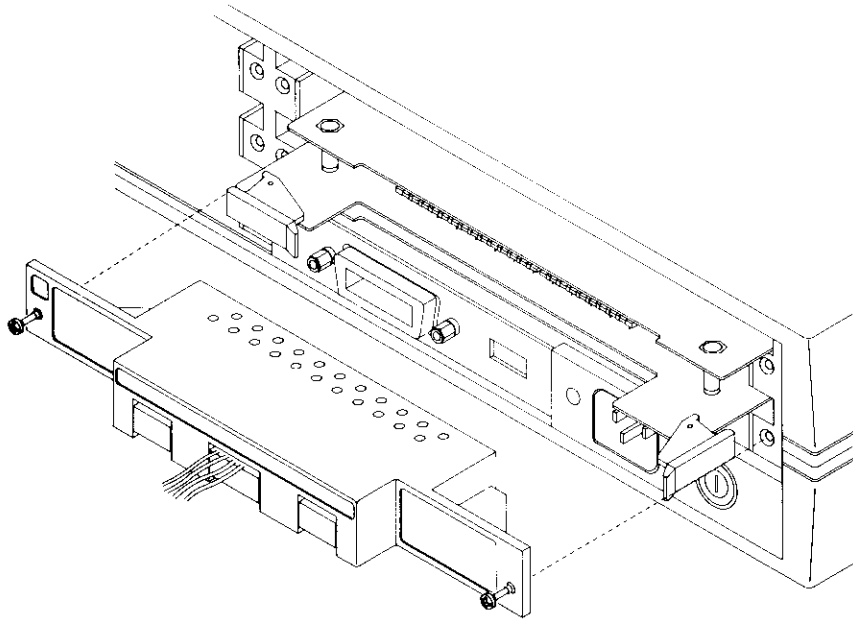

Figure 6-7. Attaching the Terminal Block

5. Labels

- a. Two labels were provided with the option assembly. One identifies the assembly as a 44470A Relay Multiplexer. There is space on the bottom of this label to type or write in a description of where this particular option is being used.
- b. Second, a series of numbered labels (1 to 5) is provided to help you identify the slot where the assembly is located. Select the appropriate number and place it in the upper left hand corner of the strain relief housing.

Configuration

Provisions have been made on the 44470A circuit board for installing simple attenuators or filter networks. An attenuator is composed of two resistors that act as a voltage divider. Three jumper locations are provided for installing components in the signal High lead, Low lead and as a shunt from High to Low. Consider the following diagram:

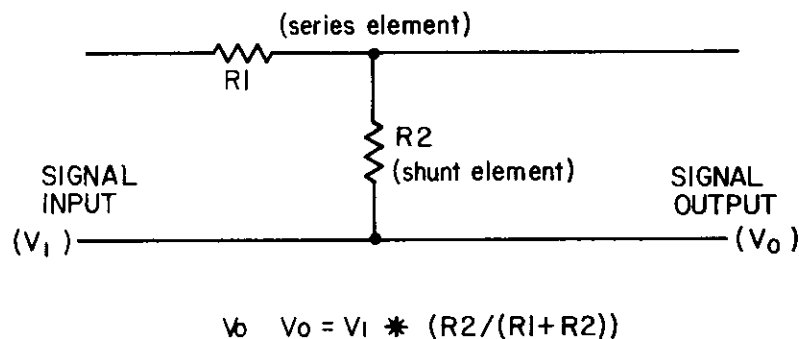

Figure 6-8. Diagram of Simple Attenuator

In order to install attenuators on the 44470A circuit board, the circuit board must be removed from the protective shields. Use caution as the 44470A assembly uses CMOS device which are susceptible to static discharge. Figure 6-9 shows the 44470A circuit board with the locations of where attenuators are to be installed.

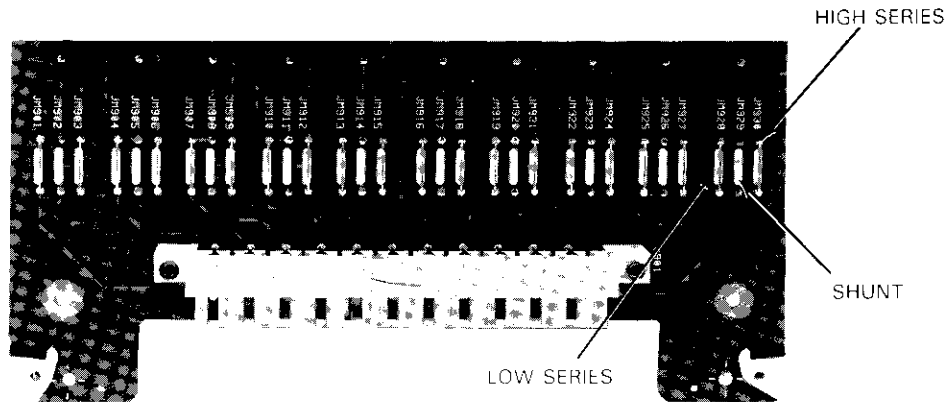

Figure 6-9. Attenuator Board Locations

One typical use for the shunt component is with 4–20 mA transducers. A 50 Ω , $\pm 1\%$, 0.5 watt resistor (-hp- part number 0699-0064) can be installed in the shunt location. The resultant voltage drop (transducer current through the resistor) can be measured by a system voltmeter. Thus, the 50 Ω resistor converts the 4–20 mA current to an 0.2 – 1 volt signal.

Accessories

-hp- part number 44480A provides an extra Screw Terminal Connector Block for the 44470A assembly.

Specifications

The specifications at the end of this chapter apply to only the 44470A assembly. These specifications are the performance standards or limits against which the assembly is tested. Do not exceed or surpass the specified limits.

Any changes in specification due to manufacturing changes, design, or traceability to the National Bureau of Standards will be covered in a manual change supplement.

Applications

The following four application examples demonstrate various uses of the 44470A Multiplexer option. Consideration should be given to your particular application before deciding which option assembly to use. The 44470A option is designed for use in measurements where noise bandwidth is not important, with a voltmeter for example. If your application requires higher isolation for noise rejection, such as with a spectrum analyzer, the 44472A VHF switch should be used.

Example 1. 4-Wire Ohms

In this example, we want to show how channel pair scanning is useful when making 4-wire ohms measurements. Two 44470A assemblies are required. Slots 1 and 2 of the 3488A will be used for the 44470A assemblies. Let's use an -hp- 3478A to make the measurements on 10 thermistors. The resistance value of the thermistors can be converted to temperature by the computer.

Connect the Ω 's sense leads of the 3478A to the common bus of one of the 44470A assemblies. It doesn't matter which assembly, but for this example, let's use the one in slot 2. Now, connect the 3478A's voltmeter input terminal to the common bus of the 44470A assembly in slot 1.

Figure 6-10 shows the voltmeter connections and how the thermistors are connected to both 44470A assemblies

A program to scan through the channels and trigger the voltmeter for the measurements is shown below. This program was written for -hp- Series 80 computers. For clarity, the program does not show the resistance to temperature conversion routine.

10 ! 4-Wire ohms example		
20 ! -HP- 85 version		
30 ! 3488A at address 709, 3478		
A at address 723		
40 CLEAR 7		
50 OUTPUT 709 ; "CPAIR 1,2) SLIS	40	CLEAR resets the 3488A and 3478A.
T 100-109"		
60 OUTPUT 723 ; "H4T4"		
70 FOR I=1 TO 10		
80 OUTPUT 709 ; "STEP"	50	Line 50 sets the 3488A to card pair slots 1 and 2 (CPAIR1,2) and sets the scan list for channels 100-109.
90 TRIGGER 723		
100 ENTER 723 ; A(I)		
110 NEXT I		
120 !		
130 ! Resistance to temperature		
conversion routine goes here	60	This line programs the 3478A for 4-wire ohms measurements (H4) and trigger hold (T4).
140 !		
150 END		
	70-110	Lines 70 through 110 set up a loop to scan through the channel list. The readings are stored in array A(I).

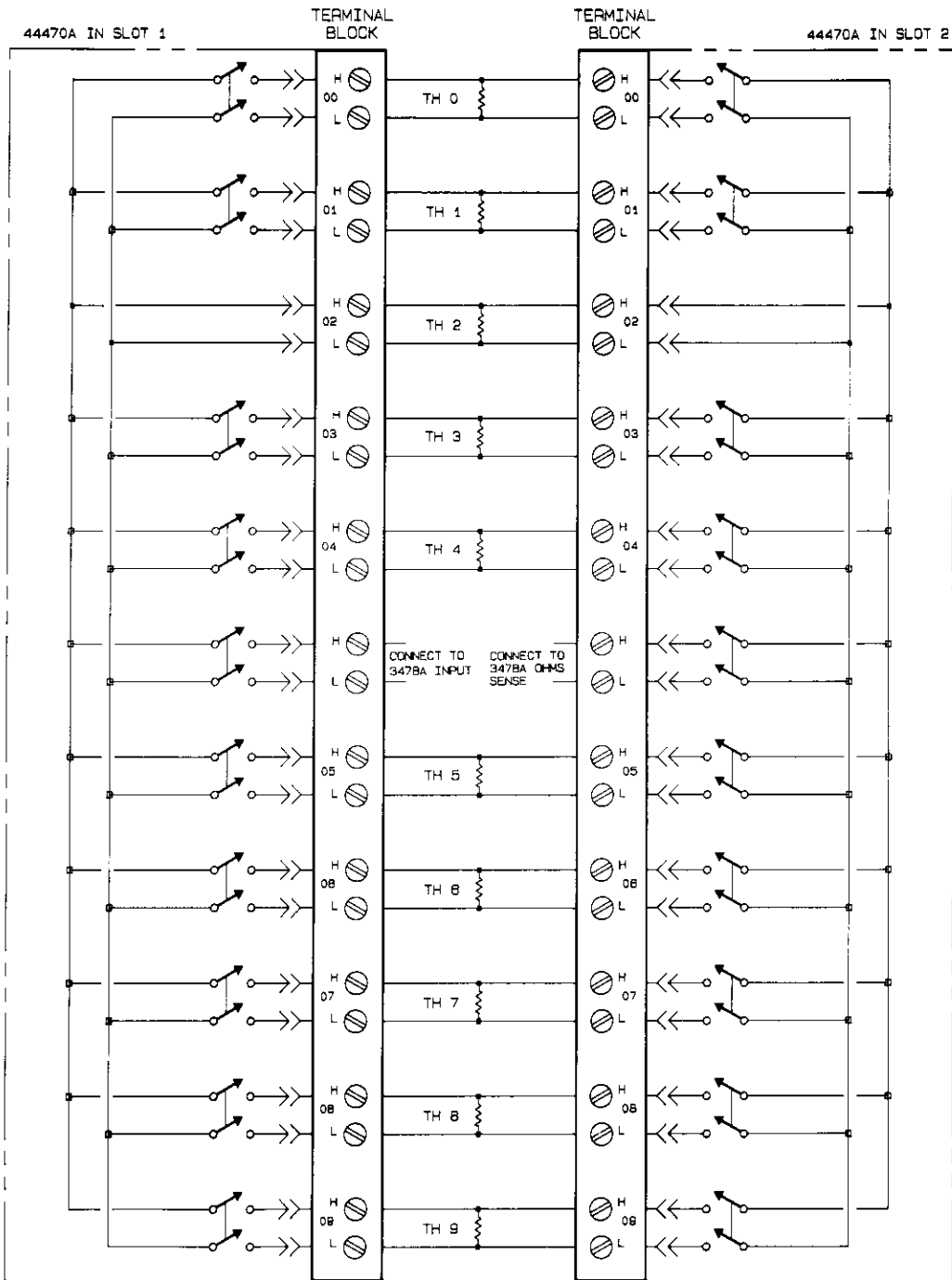

3488-B-10

Figure 6-10. 4-Wire Ohms Measurements

Example 2. Scanning Using Channel Closed

Suppose we want to scan channels 100 through 209 (44470A options in slots 1 and 2) using Channel Closed. The 44474A Digital I/O option will be in slot 5. For this example, we will again use an -hp- 3478A Digital Voltmeter.

Remember to connect both 44470A's common bus to the input terminals of the 3478A. Also, connect the 3478A's External Trigger Input port to the 44474A's Channel Closed line.

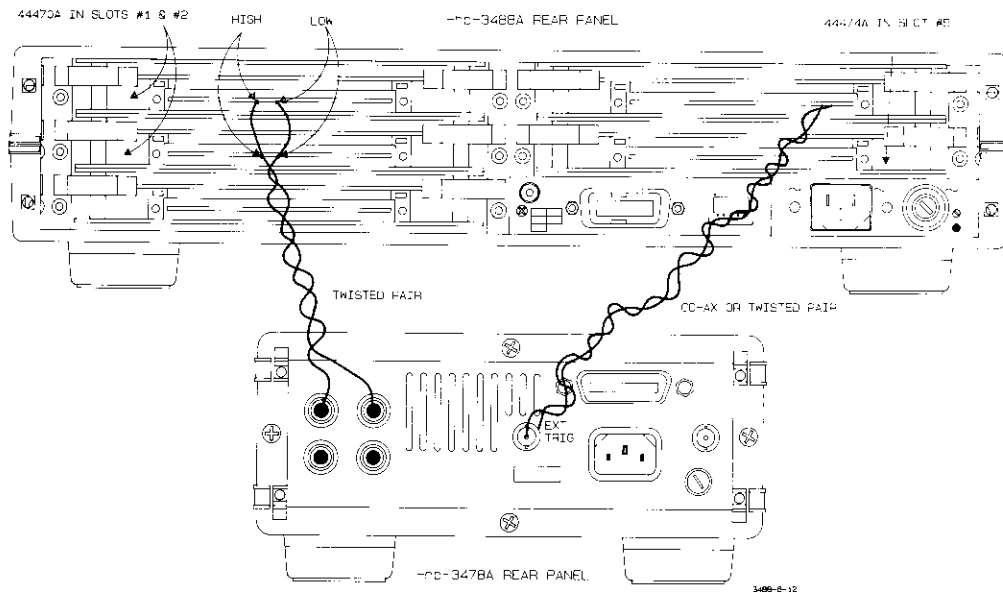

Figure 6-11. Channel Closed

The following program, written for an -hp- 85, shows the fundamental requirements for such a measurement system. Note the 3478A is triggered only by the Channel Closed pulse from the 44474A.

Line	Description
10 ! Channel Closed example	
20 ! -HP- 85 version	
30 ! 3488A at address 709, 3478A at address 723	
40 CLEAR 7	40 CLEAR resets the 3488A and 3478A.
50 OUTPUT 709 : "SLIST 100-209,0 : OMODE 5,1,1,1"	50 This line sets the 3488A for a scan list (SLIST) on channels 100 through 209. It also enables the 44474A Digital I/O option (slot 5, mode 1, polarity 1, EI enabled) for External Increment and Channel Closed.
60 OUTPUT 723 : "H0T2"	60 The 3478A is set to its Home mode (DC Volts, Auto-range, Single trigger, 4½ digit resolution, auto-zero on) with H0 and the External Trigger mode with T2.
70 FOR I=1 TO 20	
80 OUTPUT 709 : "STEP"	
90 ENTER 723 : A(I)	
100 DISP I;A(I)	
110 NEXT I	
120 END	
70-110	Lines 70 through 110 set up a loop to step through the scan list. Each reading is read into array A(I).

Example 3. Scanning Using External Increment and Channel Closed

Using a voltmeter with internal reading storage (such as the -hp- 3456A) makes the scanning even easier and faster. The main feature of this example is speed because as soon as the voltmeter completes one reading, the next channel is closed and a new reading initiated. Measurement speed is not dependent on the system computer.

Essentially, this program is the same as Example 2. Remember to connect the 44470A's common buss to the voltmeter input terminals and connect the voltmeter's External Trigger to the 3488A's Channel Closed line. Connect the 3456A's Voltmeter Complete to the 3488A's External Increment line.

The program sets the voltmeter for reading storage and then starts the scan sequence. As each reading is taken it is stored internally in the voltmeter and will be available to the computer later.

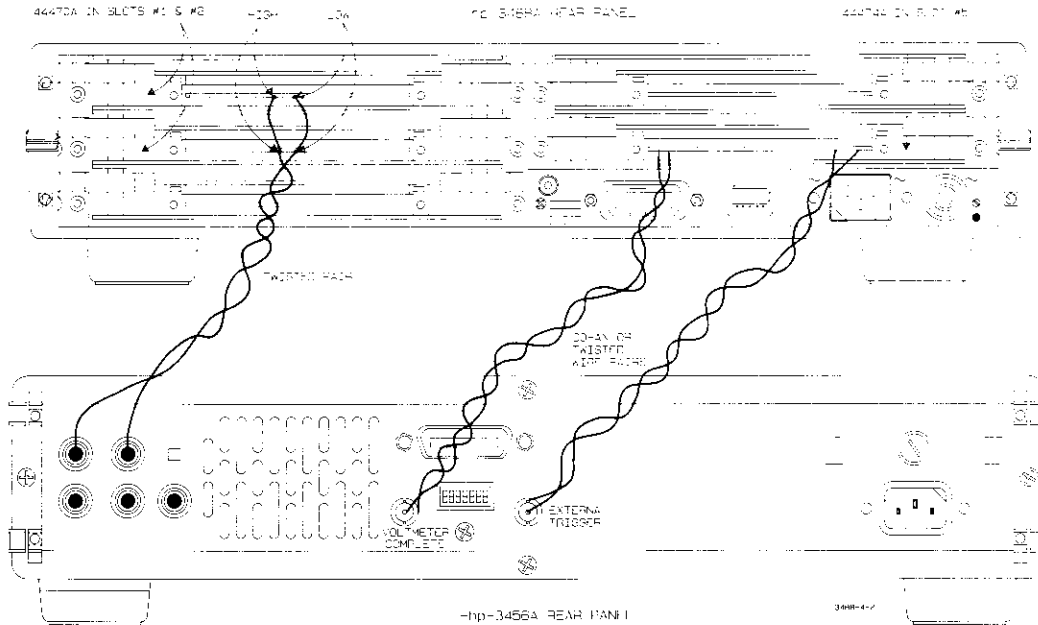

Figure 6-12. External Increment and Channel Closed

Refer to Chapter 10 for more information on setting up the Digital I/O option for External Increment and Channel Closed.

```

10 ! End of Scan sequence SRC e
   xample
20 ! -HP- 85 version
30 ! 3488a at address 709, 3456
   A at address 722
40 ON INTR 7 GOSUB 1000
50 ENABLE INTR 7:8
60 OUTPUT 709 ; "SLIST 100-209.0
   ; DMODE 5.1,0,1; MASK 1"
70 OUTPUT 722 ; "FIR1Z1T2RS1"
80 TRIGGER 709
90 GOTO 90 ! Mainline Program e
   oes here
100 END
1000 P=SPOLL(709)
1010 IF BIT(P,0) THEN DISP "END
   OF SCAN REACHED"
1020 OUTPUT 722 ; "D020STR"
1030 FOR I=1 TO 20
1040 OUTPUT 722 ; "RER"
1050 ENTER 722 ; A(I)
1060 DISP A(I)
1070 NEXT I
1080 OUTPUT 722 ; "01"
1090 STATUS 7,1 ; R
1100 OUTPUT 709 ; "STATUS"
1110 RETURN

```

Example 4. Single Ended Measurements

Using only 44470A Ten Channel Multiplexer options, a maximum of 50 channels (two wires) can be scanned for measurements. However, if you don't require the noise rejection of two wire measurements and the Lo side of all your signal sources can be connected together, you can use one 44471A and four 44470A options to provide up to 88 channels for single-ended measurements.

Figure 6-13 shows how these options are connected together in this example. Notice that all of the Hi terminals on the 44470A options connect to channel 0 on the 44471A. To measure any of the voltage sources connected to one of the Hi terminals, channel 0 on the 44471A must be closed. Furthermore, all the Lo terminals on the 44470A options connect to channel 1 on the 44471A. To measure any of

the voltage sources connected to the Lo terminals, Channel 0 must be opened and channel 1 closed. The remaining eight channels on the 44471A option can also be used for single ended measurements.

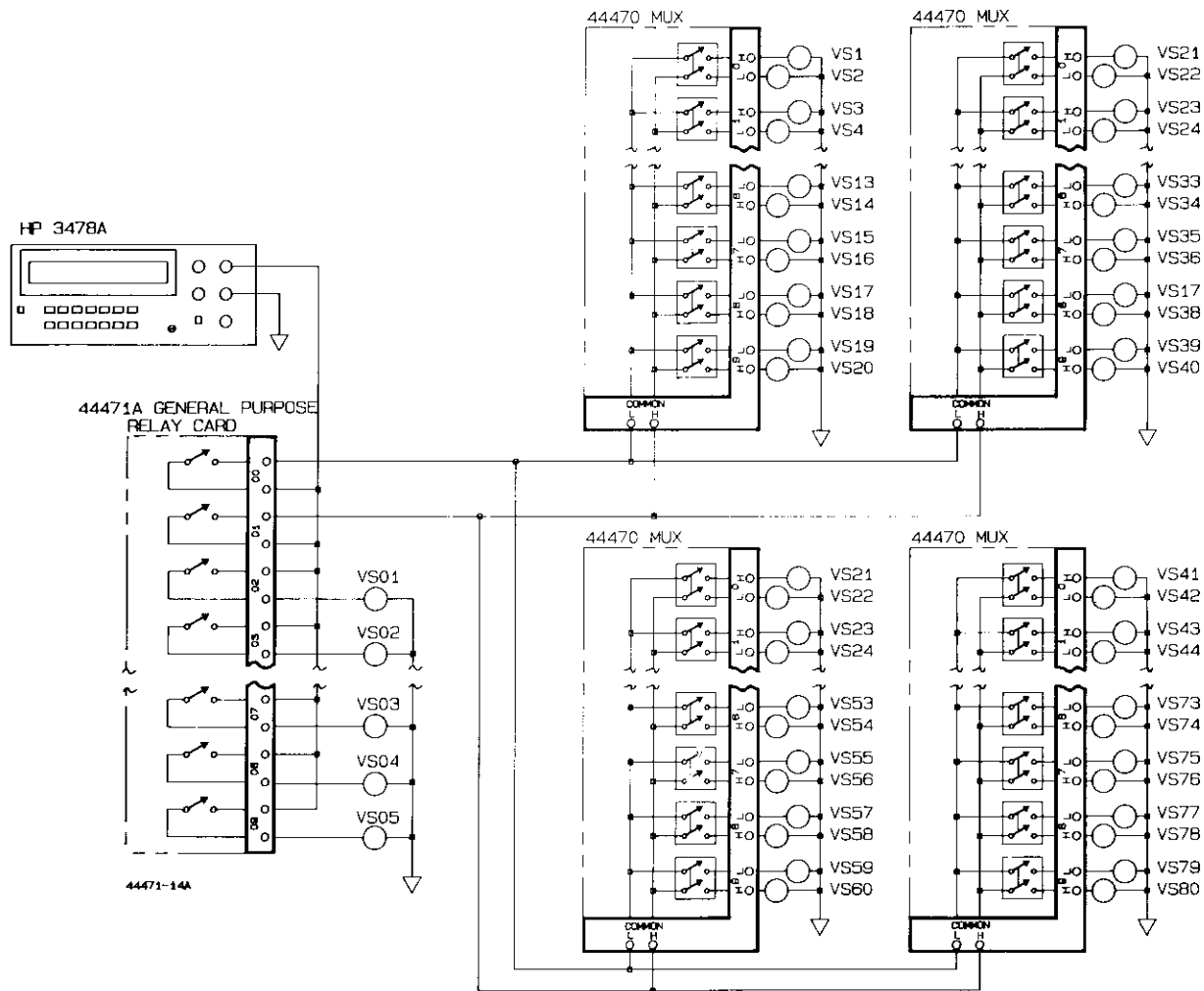

Figure 6-13. Single Ended Scanning

The associated program shows how to STEP through each of the 88 single ended channels. This program assumes that the 44471A option is mounted in slot 1 and the four 44470A's are installed in slots 2 through 5. The program uses an -hp- Model 3478A DVM for the measurements.

The program first sequences through the eight extra lines on the 44471A option (lines 50 - 90). Then, in lines 100 - 170, channel 100 is closed allowing measurements from the sources connected to the Hi terminals on the 44470A options. Finally, in lines 180 - 250, channel 100 is opened and channel 101 is closed permitting measurements from the Lo terminals on the 44470A options.

```

10 ! SINGLE ENDED SCANNING EXAMPLE
20 ! -HP- 85 VERSION WITH 3488A SWITCH AND 3478A DVM
30 ! 3488A AT ADDRESS 709, 3478A AT ADDRESS 723
40 OUTPUT 723 ;"T3"
50 OUTPUT 709 ;"SLIST 102-109,0; CMDN 1"
60 FOR I=2 TO 9 STEP 1
70 OUTPUT 709 ;"STEP"
80 TRIGGER 723
90 ENTER 723 ; A
100 PRINT "CHANNEL: ";I;"MEASUREMENT: ";A
110 NEXT I
120 ! MEASURE HI's
130 PRINT @ PRINT "HI CONNECTIONS MEASURED" @ PRINT
140 OUTPUT 709 ;"CLOSE 100; SLIST 200-509,0; CMDN -2"
150 FOR I=10 TO 50
160 OUTPUT 709 ;"STEP"
170 TRIGGER 723
180 ENTER 723 ; A
190 PRINT "CHANNEL: ";I;"MEASUREMENT: ";A
200 NEXT I
210 ! MEASURE LO's
220 PRINT @ PRINT "LO CONNECTIONS MEASURED" @ PRINT
230 OUTPUT 709 ;"OPEN 100;CLOSE101"
240 FOR I=51 TO 90
250 OUTPUT 709 ;"STEP"
260 TRIGGER 723
270 ENTER 723 ; A
280 PRINT "CHANNEL: ";I;"MEASUREMENT: ";A

```

Table 6-2. Option 010 44470A 10 Channel Relay Multiplexer Module Specifications

INPUT CHARACTERISTICS

Maximum Voltage (Terminal-terminal or terminal-chassis):
250 VDC, 250 VAC RMS, 350 VAC Peak

Maximum Current: (Per channel or module): 2 ADC, 2 AAC RMS

Maximum Power (Per channel or module): 60 W DC, 500 VA AC

Maximum power dissipated by user added components: 2 W

Thermal Offset: < 3 μ V differential or single ended

Closed Channel Resistance: < 2 Ω (end of relay life)

DC ISOLATION

	<(40°C,60% RH)	<(40°C,95% RH)
Open Channel, Channel-Channel*	> 10 ¹¹ Ω	> 10 ⁹ Ω
Hi-Lo*	> 10 ¹⁰ Ω	> 10 ⁸ Ω
Channel-Chassis*	> 10 ¹⁰ Ω	> 5x10 ⁸ Ω

(* with 1 channel closed)

AC ISOLATION/PERFORMANCE**

Capacitance:

Open Channel, Channel-Channel*	< 5 pF
Hi-Lo*	< 27 pF
Channel-Chassis*	< 80 pF

(* with 1 channel closed)

(50 Ω termination)	100 kHz	1 MHz	10 MHz
Insertion Loss (dB)	< 0.20	< 0.25	< 0.50
Crosstalk (dB)	< -73	< -53	< -33

** With chassis of all equipment connected, and with low of input lines connected to low of output lines (either directly or via 3488A switched channel).

Chapter 7

44471A

General Purpose Relay Module

Introduction

This option to the 3488A (option 011) provides 10 independent Single Pole – Single Throw (SPST, Form A) switches. Although the card will find many uses as an actuator assembly, its low thermal characteristics make it ideal for independent (non-multiplexed) signal switching.

The individual relays on this option are rated for a maximum, open circuit voltage of 250 Volts dc or ac rms. Maximum current per relay is 2 Amps dc or ac rms and maximum power per relay is 60 Watts dc or 500VA (Volt-amperes) ac. Later in this manual a complete table of specifications is provided. Maximum closed channel resistance is $< 2 \Omega$. Space is provided on the circuit board for adding contact protection circuits.

This chapter is designed to serve as a reference guide for using the 44471A General Purpose Relay Module. As such it contains programming information, installation, and configuration information, and application examples.

WARNING

The 3488A Option 011, 44471A Multiplexer Assembly uses latching relays. The state of these relays can only be altered under program control. This is an advantage in the sense that, under most conditions of failure, the relays will remain in whatever state your program has set them. However, in case of power or equipment failure, any application requiring a failsafe method of insuring that the circuits under control are in a known state must be provided by the installer.

In case of component failure or programming error, any voltage input to an option card may be present on any other terminal on the same option card.

Operation

Figure 7-1 shows that the 44471A General Purpose Relay Module consists of 10 independent Single Pole - Single Throw switches. More than one switch can be closed at a time. Therefore, if necessary, High and Low signal lines can be switched by using a pair of channels. An easier way of doing this, however, is to use two 44471A assemblies and use the CARD PAIR command (discussed later in this chapter).

Two modes of operation are possible, single channel break-before-make or multiple channels closed together. At turn on or reset (either from the front panel RESET key or the HP-IB CLEAR command), all relays on the 44471A will be opened.

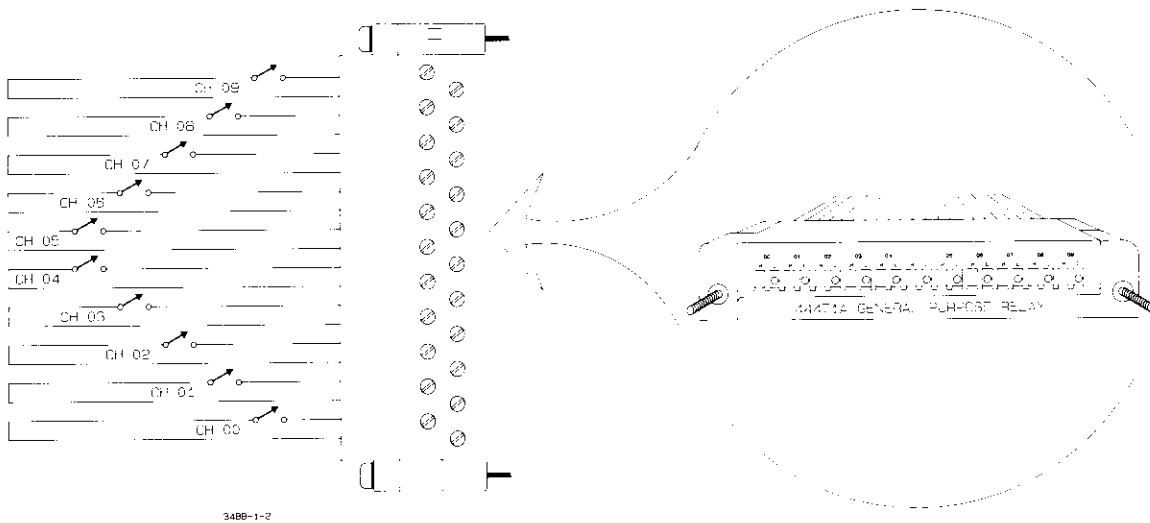

Figure 7-1. 44471A Simplified Schematic

Channels

A channel, as described in Chapter 2, refers to an individual relay, in this case a relay on the 44471A assembly. Therefore, when speaking of closing a channel, we are referring to closing a particular relay. Channel numbers are two digit numbers 00 through 09 and are repeated on each 44471A assembly. This can be seen by the numbering on the Terminal Block Edge Connector.

Channel addresses, on the other hand, are determined by which slot the 44471A assembly is installed in. Channel addresses are a three digit number where the first digit specifies the particular slot where the 44471A option is installed. The last two digits are the channel number. For example, channel address 102 means slot 1, channel 02.

The following table shows the channel addressing scheme for the five different slots.

Table 7-1. Channel Addressing Scheme

Channel number as shown on the terminal block	Channel address if 44471A assembly is in slot number:				
	Slot 1	Slot 2	Slot 3	Slot 4	Slot 5
00	100	200	300	400	500
01	101	201	301	401	501
02	102	202	302	402	502
03	103	203	303	403	503
04	104	204	304	404	504
05	105	205	305	405	505
06	106	206	306	406	506
07	107	207	307	407	507
08	108	208	308	408	508
09	109	209	309	409	509

Commands

Most of the 3488A commands can be used in controlling the 44471A assembly. In addition to the standard 3488A commands, two HP-IB interface commands can also affect the use of the 44471A. All of these commands are described using a simple format of explanation.

In the following summary of command descriptions, square brackets ([]) indicate optional parameters, whereas items in < > brackets are mandatory. For further explanation of the command code mnemonics, refer to Chapters 2 and 3.

CLOSE a channel

Command Format: CLOSE <ch. address>[,<ch. address>,<ch. address>,...]

Description

The CLOSE command is used to simply close one or more channels on the 44471A. Note that the CLOSE command does not open any channels that were previously closed. Several channels can be closed with one CLOSE command by separating the channel addresses with a comma; channels are closed in the order listed.

Examples

OUTPUT 709;"CLOSE 102,103,105" ! Closes channels 2, 3, and 5 in slot number 1

OUTPUT 709;"CLOSE 104,305" ! Closes channel number 4 in slot 1 and channel number 5 in slot 3.

OPEN a channel

Command Format: OPEN <ch. address>[,<ch. address>,<ch.address>...]

Description

OPEN is used to open individual channels on the 44471A assembly. If more than one channel is specified in the OPEN list, channels are opened in the order listed. Use the CARD RESET command to open all channels on an assembly. It is easier than listing each channel individually.

Examples

```
OUTPUT 709; "OPEN 103,105,107"      ! Relays 3, 5, and 7 are opened in slot
                                     number 1
```

VIEW a channel

Command Format: VIEW <ch. address>

Description

The VIEW command is used to look at the state (either open or closed) of a particular channel. The 3488A responds with the string "OPEN 1" if the specified channel is open. If the specified channel is closed, the 3488A responds with the string "CLOSED 0". In the 3488A display, the channel address is displayed followed by a colon and the appropriate string.

Example

```
10 OUTPUT 709; "VIEW 105"          ! VIEWs channel 5 on slot number 1
20 ENTER 709;A$                    ! input the response from the 3488A
30 DISP A$                          ! A$ will either be "OPEN 1" or "CLOSED 0"
```

CARD TYPE

Command Format: CTYPE <slot>

Description

This command causes the 3488A to respond with a description of what type of option card is located in the specified slot. The description includes the name of the card as well as the option number. In the display, the description is preceded by the specified slot number.

Card Type	Description	
Slot is empty	NO CARD	00000
10 Channel Multiplexer	RELAY MUX	44470
General Purpose Card	GP RELAY	44471
High Frequency Scanner	VHF SW	44472
Matrix Card	MATRIX SW	44473
Digital I/O Card	DIGITAL IO	44474
Breadboard Card	BREADBOARD	44475

Example

```
10 OUTPUT 709; "CTYPE 3"      ! look for the card in slot 3
20 ENTER 709; A$
30 DISP A$                    ! Card description will be displayed
```

CARD RESET

Command Format: CRESET <slot>[, <slot>, ...]

Description

RESET is used to reset all channels on the 44471A assembly to their open state. Only cards in the slots specified are affected.

Example

```
OUTPUT 709; "CRESET 2"      ! resets the option assembly in slot 2
```

CARD PAIR

Command Format: CPAIR <slot>,<slot>

Description

CARD PAIR is used to pair up two option assemblies of the same type, e.g., 44471A's. This operation will effectively assign both options to both slot numbers so that closing or opening a channel on either option will perform the same operation on the respective channel on the other option.

Commands used with the Card PAIR function are: OPEN, CLOSE, CRESET, CHAN and STEP. Of course, paired slots can be used as part of a scan list.

Executing a CPAIR command cancels any previous CPAIR command that involved either of the two options. It is possible, however, to have two sets of card pairs, e.g. slot 1 paired with 2 and slot 3 paired with 4.

Example

```
OUTPUT 709;"CPAIR 1,3" !sets the options in slots 1 and 3 as pairs
OUTPUT 709;"CLOSE 105" !closes channels 105 and 305 simultaneously
```

Executing the CPAIR command without specifying any slot numbers allows you to determine which, if any, slots are paired together. Four numbers are returned separated by commas. The first two specify slots in the first pair, the second two numbers specify the second pair. An inactive card pair is denoted by 0,0.

Example

```
OUTPUT 709; "CPAIR"
ENTER 709; A$
DISP A$
```

String variable A\$ will have the four slot numbers.
Note, you may have to dimension A\$ to 30

SCAN LIST

Command Format: SLIST [<ch. address>(, or -)<ch.address> . . . <ch. address>]

Description

Scan LIST allows you to specify a sequence of channels to be scanned. The sequence is specified as a list of up to 85 channel addresses (relay or Digital I/O lines) and/or stored setups separated by commas. Contiguous channels may be specified by entering the first and last channel addresses separated by a hyphen. STEP is used to sequentially close channels in the list.

Example

```
10 OUTPUT 709;"SLIST 104,205, 300-309, 403,0"  
20 FOR I= 1 TO 14  
30 OUTPUT 709; "STEP"  
40 NEXT I
```

In this example, the scan would start with channel 104, followed by channel 205, then channels 300, 301, 302, ... 309, and finally channel 403. The 0 channel specified at the end of the list is a stop channel and opens the last channel closed (channel 403) but does not close any other channel.

Notes

1. Channels may be scanned in any sequence, i.e., 309-300.
2. Stepping beyond the last channel specified in the Scan List causes a wrap-around to the first channel in the list. The number 0 can be used as a stop channel.
3. Refer to the Advanced Operations section this chapter for information on using the External Trigger and Channel Closed features.
4. The commands OPEN, CLOSE, CRESET, or RECALL will have no effect on the scan list even though the state of individual channels may change.
5. Stored setups may be recalled as part of a Scan List simply by specifying the register number. For example, SLIST 104,105,106,25,200,201. Here, register 25 has the stored setup.

STEPping through the Scan List

Command Format: STEP

Description

STEP is used to open the last channel closed and close the next channel in the Scan List. If STEP is executed and no Scan List exists, the 3488A will generate an error.

The 3488A uses a pointer to keep track of which channel in the Scan List is currently closed. When STEP is executed, that channel is opened and the next item in the list is checked. If the next item in the list is a relay or Digital I/O line, that channel is closed. If the next item in the list is a stored setup, that setup is recalled. Channels that are closed as part of a stored setup will remain closed, that is, they are not opened by the next execution of the STEP command.

For information on External Increment and Channel Closed, refer to the Advanced Operation section of this chapter.

Example

```
10 OUTPUT 709; "SLIST 100 - 109;CMON 1"  
20 FOR I=1 TO 10  
30 OUTPUT 709;"STEP"  
40 NEXT I
```

CHANnel Command

Command Format: CHAN [<ch. address>]

Description

CHAN is used to open the last channel closed by either STEP or CHAN (whichever was most recent) and close the specified channel. If no channel is specified with CHAN, the 3488A will respond with the last channel closed by either STEP or CHAN. If no channel has been closed since the last reset, then CHAN returns the number 0.

If a Scan List is in effect when CHAN is executed, the 3488A will search through the list and position the Scan List pointer to the channel specified by CHAN. If CHAN specifies a channel that is not in the Scan List, and the STEP is executed, the 3488A will open the channel closed by CHAN and then go to the beginning of the Scan List.

Example

OUTPUT 709; "CHAN 105" ! Closes channel 105

OUTPUT 709; "CHAN"

ENTER 709; A\$

DISP A\$! A\$ will contain the last channel closed, i.e., 105

CARD MONITOR mode

Command Format: CMON <slot>

Description

Card Monitor is used to look at the state of the individual option assemblies in the specified slot (1 – 5). Specifying slot 0 will cause the monitor mode to be cancelled. If a negative number is used for the slot, the 3488A will go to its monitor tracking mode.

When used to monitor the 44471A assembly, the display shows the slot number (extreme left) and those channels that are closed, separated by commas. The MONitor annunciator also comes on.

Example

OUTPUT 709;"CLOSE 102,103,107; CMON1"

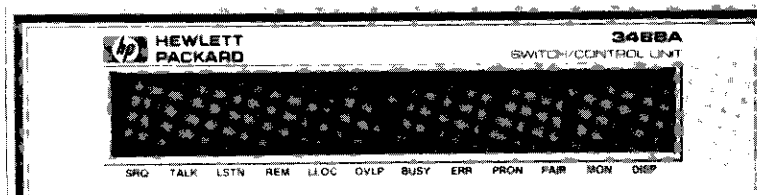

This photo shows slot 1, channels 2, 3 and 7 closed.

The format of the display can be summarized as:

s: n,n,n,n,n,n,n,n,n

where s represents the slot number being monitored and n is a channel number.

Advanced Operations

Advanced Operations provide you with more capabilities when using the 3488A. It may be important, for example, to tell the system voltmeter when a channel has been closed and thus take a measurement. Or maybe you need to close the next channel in a scan list when some external event has taken place, perhaps as soon as the voltmeter has completed its reading. Most operations can be performed with only the basic commands, but for those times when you need something more, the advanced operations should meet your switching needs.

External Increment and Channel Closed

External Increment (EI) provides a method of sequencing through a Scan List without system computer intervention. Typically, EI is connected to the Voltmeter Complete* output on a system voltmeter. Thus, when the voltmeter has completed its measurement, it signals the 3488A to step to the next channel in the list. The EI input is rising-edge triggered and TTL compatible.

Channel Closed (CC) provides a 15 μ S TTL pulse for signalling when a channel has been closed in the 3488A. This signal can be tied to the External Trigger input of a voltmeter to trigger it when a channel is closed. Together, EI and CC can be used with a system voltmeter to sequence through a scan list without any intervention by the system computer.

Using the External Increment and Channel Closed features requires the use of a 44470A Digital I/O option. This also means that the Digital I/O option cannot be configured in Handshake Mode #5 when it is used for scanning (it can be used statically, however). The DMODE command is used to specify the handshake mode, Polarity and EI. Only one Digital I/O option can be configured for EI at a time. If one option is configured to accept EI and another is subsequently enabled, the first card will be disabled.

Even though the only specifier we are interested in is EI, the mode and polarity specifiers must be included. The format for specifying DMODE is as follows:

```
DMODE <slot>[, <mode>][, <polarity>][, <EI>]
```

* Voltmeter Complete is a feature found on most Hewlett-Packard digital voltmeters to signal the completion of a measurement by means of a TTL compatible pulse.

The MODE specifier is as follows:

Definition	Value
Static Mode	1
Static Mode for read back	2
R/W & Strobe	3
RD & WT Strobe	4
HAndshake (no EI)	5

Any of the Modes may be specified for use with External Increment except the Handshake Mode (value 5).

The Polarity specifier is the sum of weighted values and is defined as follows:

Definition	Value
Lower 8-bits polarity	1 = Low true
Upper 8-bits polarity	2 = Low true
PCTL Polarity	4 = Low busy
PFLG Polarity	8 = Low busy
I/O Direction line Polarity	16 = Low input mode

EI is enabled by specifying 1. It is disabled with a specifier of 0.

Refer to Chapter 10 for more information on setting up the 44474A Digital I/O option for External Trigger and Channel Closed.

Delay

Command Format: DELAY [<time in mS>]

Description

The DELAY command is used to insert a time delay between the time that a channel is closed and the time the next command can be executed and the channel closed pulse is output. The delay time may be specified from 0 to 32,767 mS (32.767 seconds) in 1 mS increments. The delay time does not become effective until either CHAN or STEP is executed.

If any command is sent to the 3488A during the delay time, the command will be executed as soon as the delay time is complete. If there is not a time value sent with the DELAY command, the 3488A will respond with the current value of the delay time.

Remember that the Channel Closed pulse will use whichever 44474A assembly has External Increment enabled.

Examples

OUTPUT 709; "DELAY 45" ! The delay time is 45 mS = .045 Sec.

OUTPUT 709; "DELAY"

ENTER 709; A

DISP A ! Variable "A" will show the current delay value.

HP-IB Interface Commands

Only two interface commands affect the state of the 44471A channels: TRIGGER (Group Execute Trigger) and CLEAR (Device Clear or Selected Device Clear). TRIGGER performs the same function as the 3488A STEP command. In other words, the two commands:

TRIGGER 7 (or TRIGGER 709)

and

OUTPUT 709; "STEP"

perform the same function as far as the 44471A assembly is concerned.

CLEAR, whether a Device Clear or Selected Device Clear, simply resets the 3488A and hence all relays will go to their open state.

44471A Assembly Installation

This portion of the chapter is written specifically for the service trained technician. It provides the necessary information for a person trained in electronic circuitry to configure and install the option assembly. Carefully read through this section and adhere to all cautions and warnings.

WARNING

Only qualified service trained personnel should remove, configure, or install the 3488A option assemblies. Disconnect the 3488A power cord from the back of the instrument prior to installing the option assemblies.

The 3488A Option 011,44471ARelay Multiplexer, uses latching relays. The state of these relays can only be altered under program control. This is an advantage in the sense that, under most conditions of failure, the relays will remain in whatever state your program has set them. However, in case of power or equipment failure, any application requiring a failsafe method of insuring that the circuits under control are in a known state must be provided by the installer.

In case of component failure or programming error, any voltage input to an option card may be present on any other terminal on the same option card.

When you initially received your 3488A, the option assemblies were not installed in the mainframe. Each option assembly was packaged separately along with a terminal block edge connector and a two piece strain relief housing. In addition, two labels were provided for option identification.

CAUTION

Use clean handling and anti-static procedures when removing, configuring and installing the option assemblies. The circuit boards must be kept clean to ensure compliance with impedance specifications. The option assemblies as well as the 3488A mainframe contains CMOS devices which are susceptible to static discharges.

A few simple steps are required to install the 44471A assembly. Carefully observe to orientation of the assembly and terminal block as you install them.

1. Pre-installation

- a. Remove the ac power cord from the 3488A before installing any option assembly.
- b. Face the rear panel of the 3488A toward you.
- c. Select a slot. Refer to Figure 7-2, the 3488A has five slots for installing option assemblies. The 44471A can be used in any of the five slots.

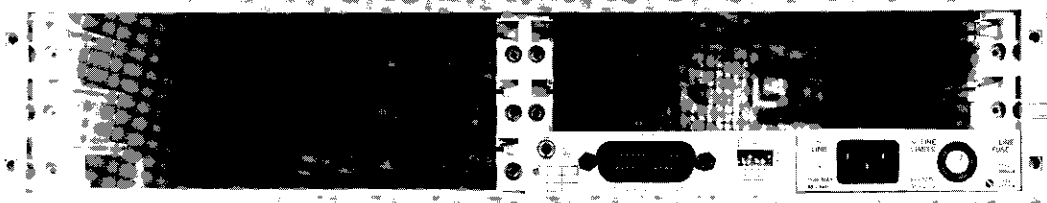

Figure 7-2. Rear Panel View of the 3488A

2. Option assembly installation

- a. Hold the option assembly, component side down, by the metal shields. Insert the circuit card into the slot guides and slide toward the front of the instrument. Push firmly until the assembly 'snaps' into place. Fold the plastic levers next to the assembly. These levers lock the option into the mainframe.

NOTE

To remove the option assembly, simply unfold the plastic tab levers. This will release the locking mechanism and pull the option out of the mainframe connector.

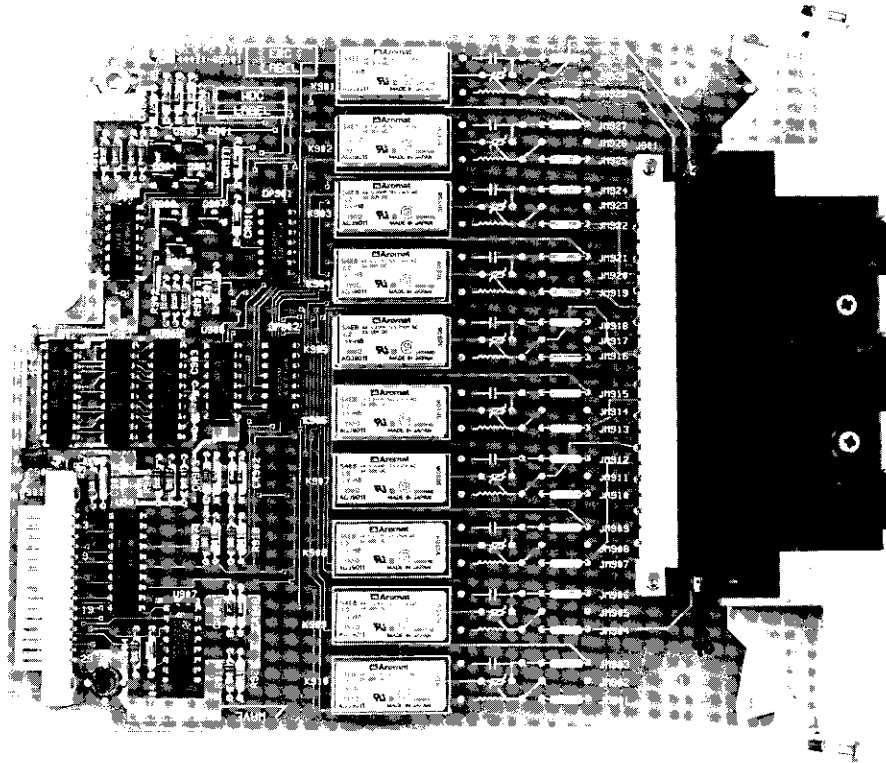

Figure 7-3. Option Card

3. Terminal Block Wiring

a. Wire the Terminal Block Edge Connector. The following photograph shows the channel connection sequence for the 44471A Terminal Block Edge Connector. This terminal block is keyed to fit only the 44471A assembly. Extra terminal blocks are available under the -hp- part number 44481A. This terminal block was designed to accept wires in the range of 18 to 26 AWG.



Figure 7-4. Terminal Block

4. Strain Relief

a. Secure the terminal block to the strain relief housing with the captive screws on the terminal block. Make certain that the screws used to tighten the connector wires to the terminal block are accessible through the strain relief housing.

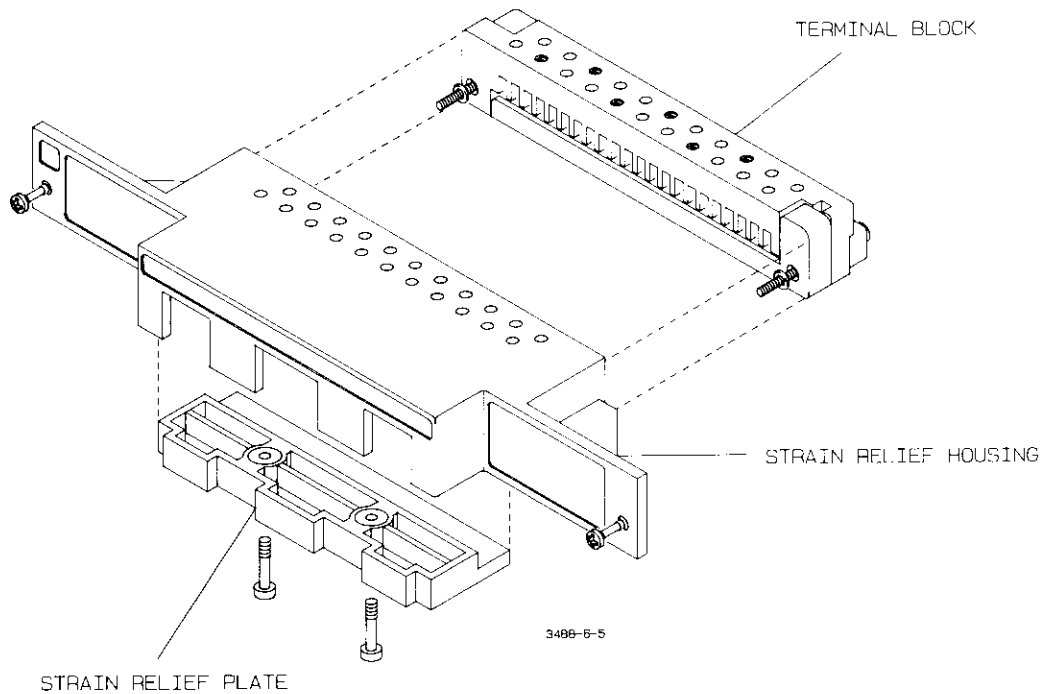

Figure 7-5. Strain Relief Housing

b. Route the wires evenly through the three strain relief cutouts. This will ensure a uniform amount of strain relief. If only a few wires are used, they should go through the middle cutout.

c. To protect wires smaller than 22AWG it is recommended that these wires be bundled together starting no more than 4" from the back of the 3488A. Failure to do so may cause wires to break at the strain relief. To illustrate the need for this, a 26AWG wire can survive about 7 to 8 pounds of tension before breaking. A bundle of 10, however, could survive up to 70 pounds of tension.



Figure 7-6. Cable Routing

d. Secure the strain relief plate to the strain relief housing (ribbed side down). Do not over tighten the screws.

e. Push the terminal block with strain relief housing onto the option assembly connector. Tighten the two screws on either end of the housing.

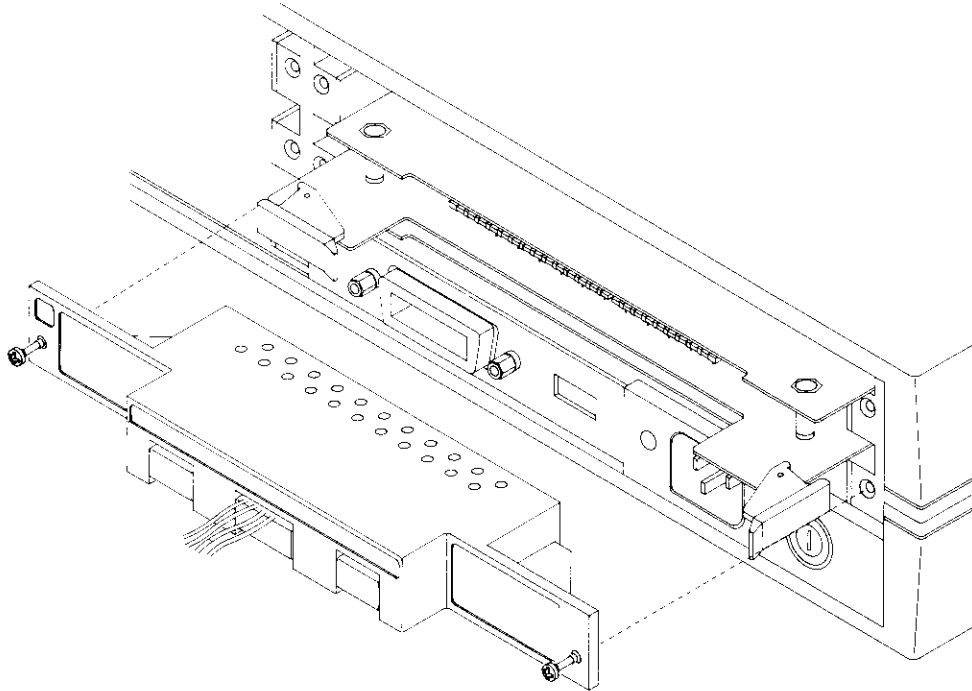

Figure 7-7. Attaching the Terminal Block

5. Labels

- a. Two labels were provided with the option assembly. One identifies the assembly as a 44471A Relay Multiplexer. There is space on the bottom of this label to type or write in a description of where this particular option is being used.
- b. Second, a series of numbered labels (1 to 5) is provided to help you identify the slot where the assembly is located. Select the appropriate label and place in in the upper left hand corner of the strain relief housing.

Configuration

Whenever relay contacts open or close, electrical breakdown can occur between the contacts. This can cause high frequency radiation, voltage and current surges, and physical damage to the relay contacts.

Provisions have been made on the 44471A circuit board for installing simple protection networks. These simple networks provide contact protection when actuating ac power line for inductive loads.

Although many types of contact protection networks can be used, only RC networks and varistors are described here. Refer to Figure 7-8.

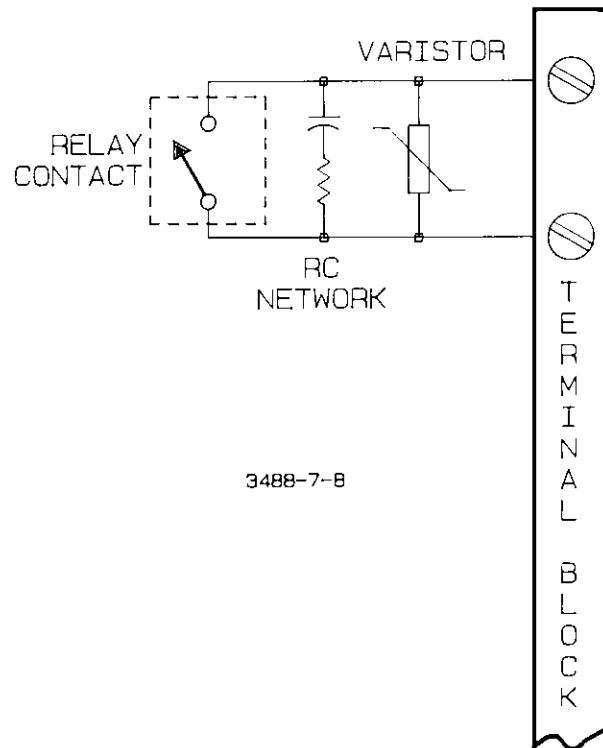

Figure 7-8. Contact Protection Networks

In designing RC protection networks, the protection resistor R_p is selected as a compromise between two values. The minimum value of R_p is determined by the maximum acceptable relay contact current (I_o). Referring to the specification table for this option, we find that the maximum allowable relay current (I_o) is 2 Amps ac rms or 2 Amps dc. Thus, the minimum value for R_p is V/I_o , where V is the peak value of the supply voltage.

$$R_p = V/I_o = V/2 \quad \text{Equation 1}$$

The maximum value for R_p is usually made equal to the load resistance, R_l . Therefore, the limits on R_p can be stated as:

$$V/I_o < R_p < R_l \quad \text{Equation 2}$$

Note, the actual value of I_o in a circuit is determined by the equation:

$$I_o = V/R_l \quad \text{Equation 3}$$

Where V is the peak value of the source voltage and R_l is the resistance of the load. Equations 1 and 2 use I_o as the maximum allowable relay current to determine the minimum value of R_p . The value for I_o calculated in Equation 3 will be used to determine the value of the protection capacitor, C_p .

In determining the value of the protection network capacitor C_p , there are several things that need to be considered. First, the total circuit capacitance (C) must be such that the peak voltage across the open relay contacts does not exceed 353 Volts peak ($250V_{rms} = 353 V_p$). The equation for determining the minimum allowable circuit capacitance is:

$$C \geq (I_o/353)12L \quad \text{Equation 4}$$

where L = the inductance of the load and I_o is the value calculated in Equation 3.

In reality, the total circuit capacitance (C) is made up of the wiring capacitance plus the value of the protection network capacitor C_p . Therefore, the minimum value for C_p should be the value obtained for the total circuit capacitance, C , from equation 3. Indeed, the actual value used for C_p should be substantially greater than the value calculated for C .

Let's work through an example and see what the typical values for an RC protection network might be. Our circuit is shown in Figure 7-9. The load is a small ac motor running off of a 120V ac line (170 V peak). This motor draws a maximum of 2 amps.

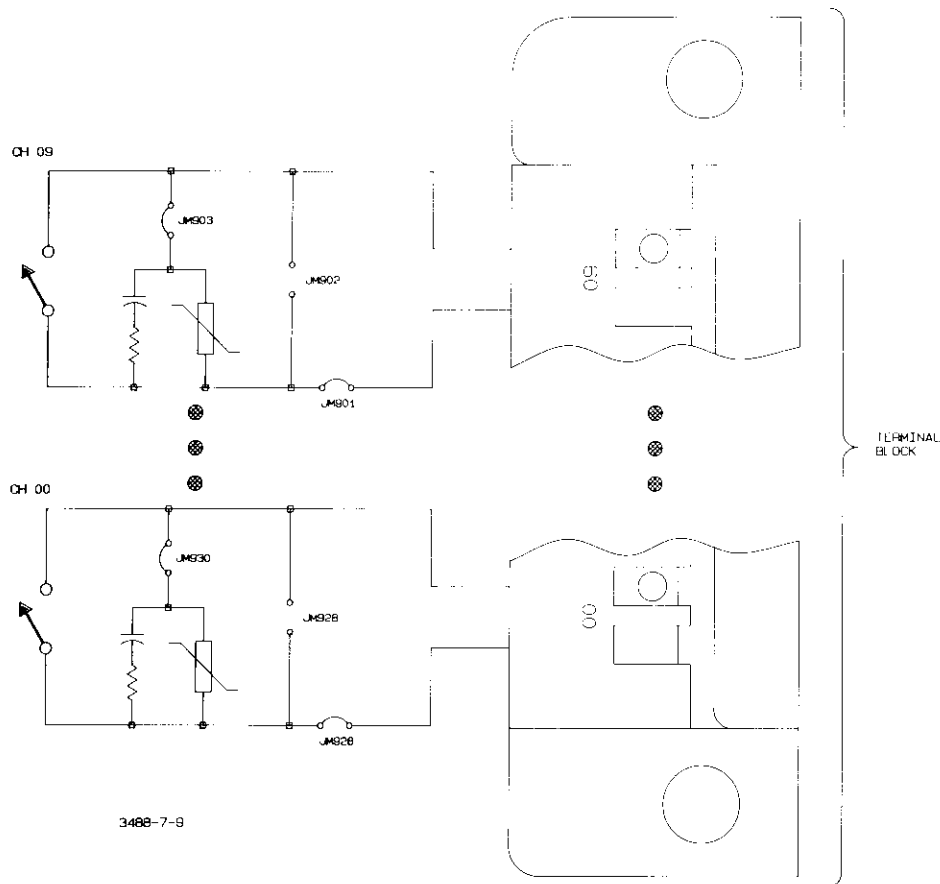

Figure 7-9. RC Protection Network

Using Equation 1 we can find the minimum value for R_p :

$$R_p = V/I_o = 170/2 = 85 \Omega$$

The maximum value for R_p would be equal to the load resistance or 400Ω . Therefore, any resistor (preferably at least 1 watt) between 85 and 400Ω 's will suffice.

To keep the peak contact voltage below $353V$ peak, use equation 3 to determine I_o :

$$I_o = V/R_1 = 170/400 = .425 \text{ A}$$

Now use equation 4 to determine C :

$$C \geq (I_o/353)^2 L = (0.425/353)^2 (0.1) = 0.144 \mu\text{F}$$

Since R_p can vary between 85Ω 's and 400Ω 's, an appropriate protection network to be connected to this circuit is $R_p = 220 \Omega$'s and $C_p = 0.15 \mu\text{F}$.

Figure 7-10 shows where protection networks should be mounted on the 44471A circuit assembly. Note that with the RC network in shunt (parallel) with the the relay contacts, there is a loss of high isolation when the relay is open. Remember that only qualified service trained personnel should remove, configure, or install the option assemblies.

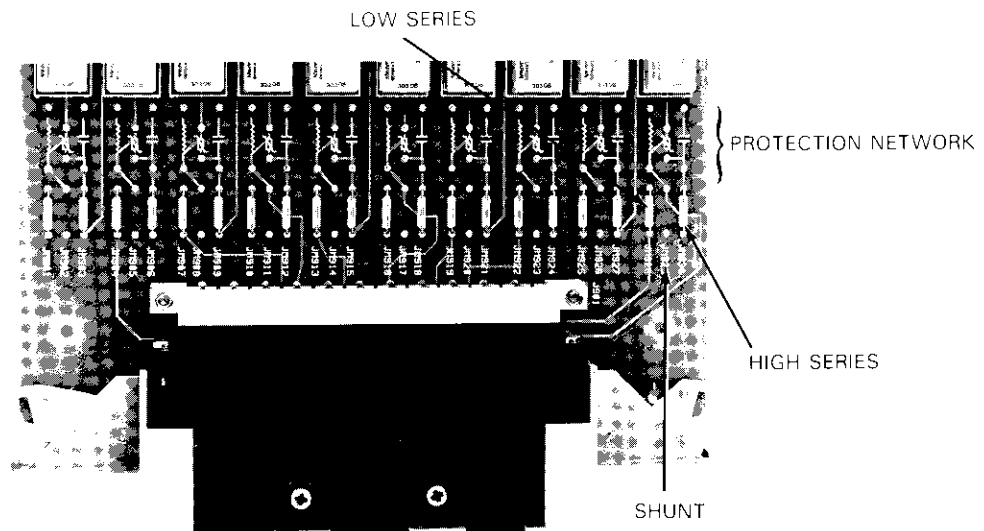

Figure 7-10. Locations for Protection Networks

Using Varistors

Just as contact protection circuits are important to suppress noise while relay contacts are opening and closing, transient protection should also be provided while the relays are open. This is the purpose of the varistor. When selecting a varistor, make certain that it has a voltage rating sufficient for your application. A typical 250 VAC varistor can be purchased from Hewlett-Packard with the part number 0837-0227.

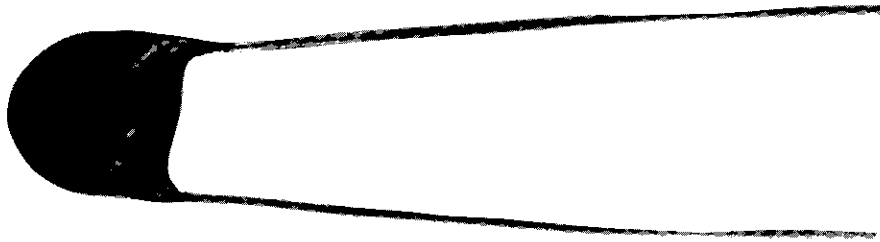

Figure 7-11. Varistor

CAUTION

When the 44471A option is used to switch power sources capable of delivering more than 2 amps, an external 2A fuse should be used to prevent accidental damage to the 44471A.

Accessories

-hp- part number 44481A provides an extra Screw Terminal Connector Block for the 44471A assembly.

Specifications

The specifications at the end of this chapter apply to only the 44471A assembly. These specifications are the performance standards or limits against which the assembly is tested. Do not exceed or surpass the specified limits.

Any changes in specifications due to manufacturing changes, design, or traceability to the National Bureau of Standards will be covered in a manual change supplement.

Application Examples

Example 1. Using the 44471A as an Actuator

One primary use of the 44471A General Purpose Switch is voltage switching for applications with 500VA or less. This example shows how to use the 44471A in two different applications: Low voltage switching (not requiring a snubber circuit) and High voltage switching requiring a snubber circuit.

Low Voltage Switching Procedure

Figure 7-12 shows two simple ways the 44471A can be used to switch operating power to low voltage devices. The top diagram illustrates how the relay switch is used to complete a circuit and sound the alarm. To sound the alarm, execute, CLOSE 100. (The 44471A Assembly is installed in slot 1 of the 3488A.) To turn off the alarm, execute OPEN 100.

The lower diagram demonstrates switching DC voltage (+5V) to operate some device. A typical application where this type of switching might be used is to supply operating power to a device under test. To apply power to the device, execute CLOSE 101. To remove operating power, execute OPEN 101.

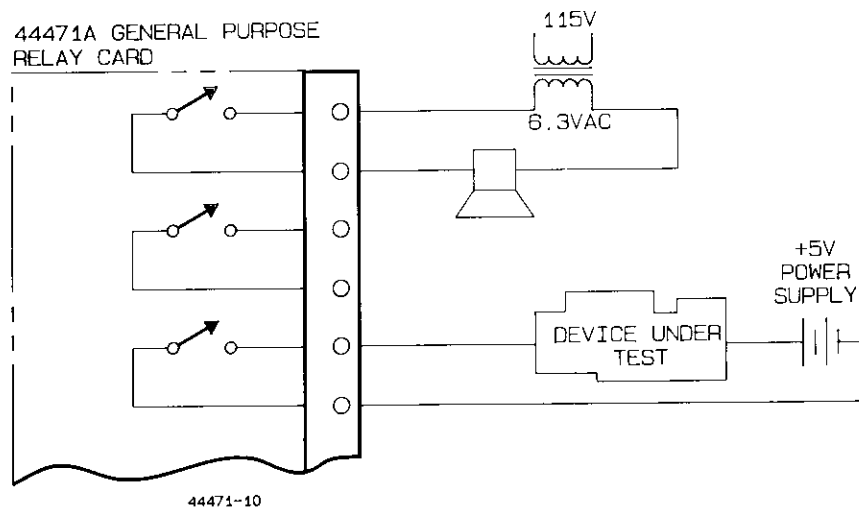

Figure 7-12. Low Voltage Actuator

High Voltage Switching Procedure

Since the relays on the 44471A can handle voltages up to 250V rms at 2 amps, it is ideally suited for switching ac line voltages to items such as air solenoids, lights, and motor starters. In this example we will see how the 44471A is used to control (turn on) motor starters.

Although the 44471A can directly control motors up to 2/3 horsepower, the range of motors it can handle can be greatly increased by using motor starters. This option assembly can be used to control the motor starter, essentially supplying the voltage to turn the starter on.

Generally, motor starters are only turned on for a short period of time. After that, the motor runs by itself and is turned off by some external circuit. In this example, the internal timer in the computer will be used to determine the "on" time of the motor starter: 3 seconds. Figure 7-13 shows a typical connection diagram and computer (BASIC) program.

CAUTION

Although a specific contact protection network (snubber circuit) is shown, you should consult the Configuration section of this manual before attempting run the program and provide adequate contact protection for your particular circuit.

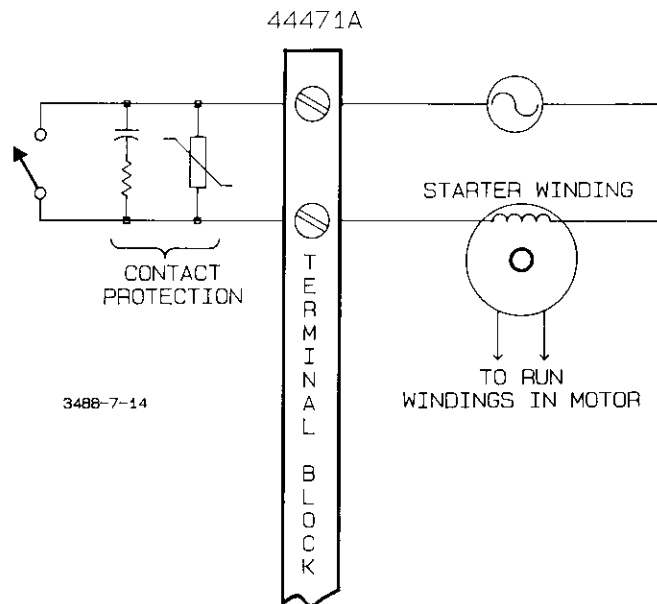

Figure 7-13. High Voltage Actuator

Example 2. Using the 44471A as a Resistance Programmer

Many types of power supplies and other electronic equipment use external resistor networks to "program" the output voltage. Change the external resistors and a change in out results. The 44471A provides an elegant solution to programming these types of devices.

Up to 1024 different values can be programmed by using only one 44471A assembly and 10 resistors. As shown in Figure 7-14, the relay contacts are wired in series with each other and in parallel with a string of binary weighted resistors. Any combination of channels may be closed providing the 1024 different possibilities.

For example, to select the 10 Ω resistor, close all relays except channel 0. To select the 20 Ω resistor, close all relays except channel 1. If you need 30 Ω, close all relays except channels 0 and 1 (10 Ω plus 20 Ω = 30 Ω). In this way, by selectively opening and closing combinations of channels, virtually any resistance value from 0 Ω to 1024 Ω (in 10 Ω increments) can be developed.

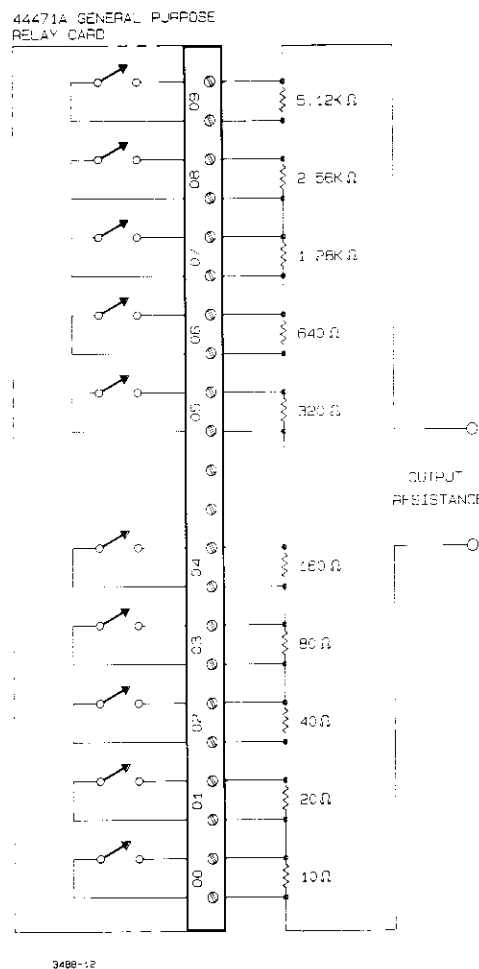

Figure 7-14. Binary Resistance Programming

There are many variations in this basic circuit. For example, if you only need 100 increments, equal value resistors can be used. If you use 10 Ω resistors, values of 10, 20, 30, 40, ... 80, 90, and 100 Ω can be developed.

In low current applications, a voltage can be applied across the resistors and the relays used to tap off the desired voltage. Refer to Figure 7-15.

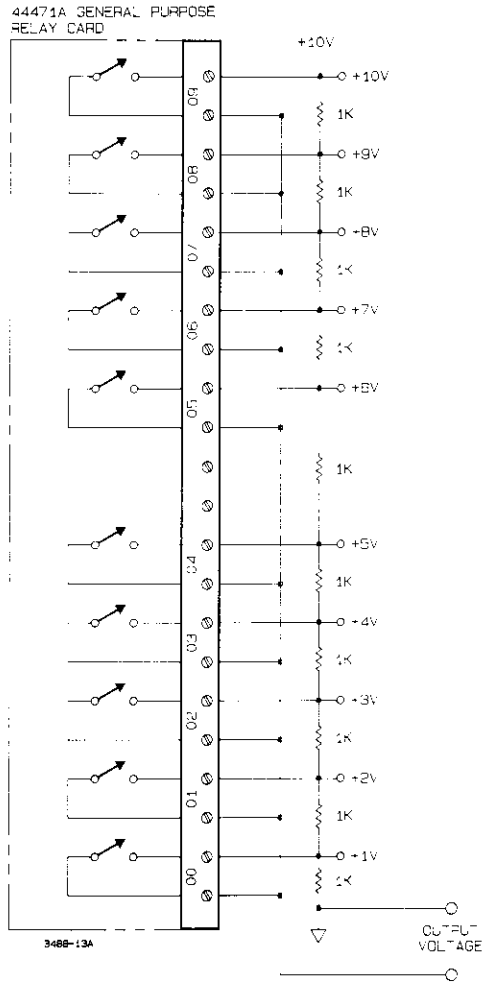

Figure 7-15. Voltage Divider

Example 3. Single Ended Measurements

Using only 44470A Ten Channel Multiplexer options, a maximum of 50 channels (two wires) can be scanned for measurements. However, if you don't require the noise rejection of two wire measurements and the Lo side of all your signal sources can be connected together, you can use one 44471A and four 44470A options to provide up to 88 channels for single-ended measurements.

Figure 7-16 shows how these options are connected together in this example. Notice that all of the Hi terminals on the 44470A options connect to channel 0 on the 44471A. To measure any of the voltage sources connected to one of the Hi terminals, channel 0 on the 44471A must be closed. Furthermore, all the Lo terminals on the 44470A options connect to channel 1 on the 44471A. To measure any of the voltage sources connected to the Lo terminals, Channel 0 must be opened and channel 1 closed. The remaining eight channels on the 44471A option can also be used for single ended measurements.

The associated program shows how to STEP through each of the 88 single ended channels. This program assumes that the 44471A option is mounted in slot 1 and the four 44470A's are installed in slots 2 through 5. The program uses an -hp- Model 3478A DVM for the measurements.

The program first sequences through the eight extra lines on the 44471A option (lines 40 - 90). Then, in lines 100 - 170, channel 0 is closed allowing measurements from the sources connected to the Hi terminals on the 44470A options. Finally, in lines 180 - 250, channel 0 is opened and channel 1 is closed permitting measurements from the Lo terminals on the 44470A options.

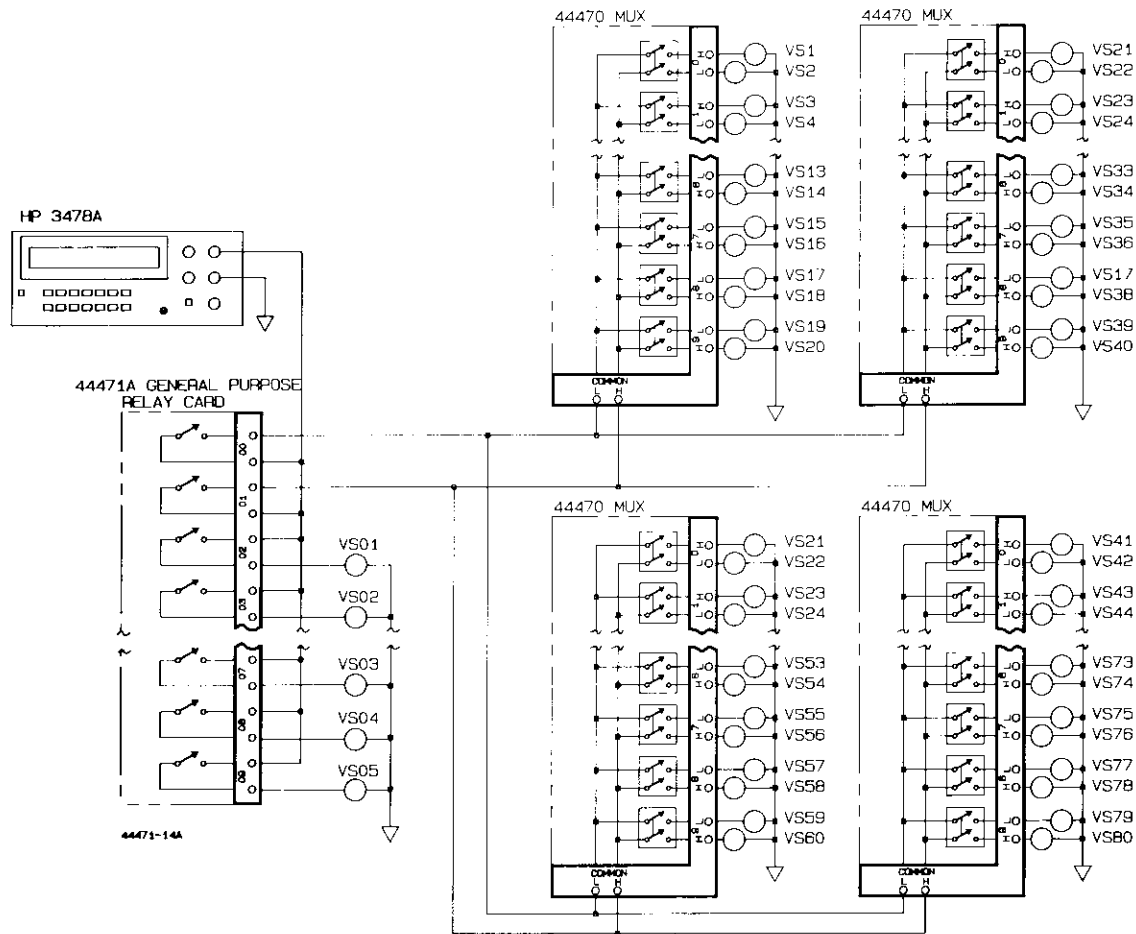

Figure 7-16. Single-ended Measurements

```

10 ! Single Ended scannint exam
   file
20 ! -HP- 85 version
30 ! 3488A at address 709, 3478
   A at address 723
40 OUTPUT 723 ; "T3"
50 OUTPUT 709 ; "RESET; SLIST 10
   2-109.0; CMON 1"
60 FOR I=2 TO 9 STEP 1
70 OUTPUT 709 ; "STEP"
80 TRIGGER 723
90 ENTER 723 ; A
100 PRINT "CHANNEL: "; I; "MEASURE
   MENT: "; A
110 NEXT I
120 ! Measure Hi's
130 PRINT @ PRINT "Hi CONNECTION
   S MEASURED:" @ PRINT
140 OUTPUT 709 ; "CLOSE 100; SLIST
   200-509.0; CMON -2"
150 FOR I=10 TO 50
160 OUTPUT 709 ; "STEP"
170 TRIGGER 723
180 ENTER 723 ; A
190 PRINT "CHANNEL: "; I; "MEASURE
   MENT: "; A
200 NEXT I
210 ! Measure Lo's
220 PRINT @ PRINT "Lo CONNECTION
   S MEASURED:" @ PRINT
230 OUTPUT 709 ; "OPEN 100; CLOSE
   101"
240 FOR I=51 TO 90
250 OUTPUT 709 ; "STEP"
260 TRIGGER 723
270 ENTER 723 ; A
280 PRINT "CHANNEL: "; I; "MEASURE
   MENT: "; A
290 NEXT I
300 OUTPUT 709 ; "RESET"
310 END

```

Table 7-2. Option 011 44471A 10 Channel General Purpose Relay Module Specifications

INPUT CHARACTERISTICS

Maximum Voltage (Terminal-terminal or terminal chassis):
250 VDC, 250 VAC RMS, 350 VAC Peak

Maximum Current (Per channel): 2 ADC, 2 AAC RMS
(Per module): 20 ADC, 20 AAC RMS

Maximum Power (Per channel): 60 W DC, 500 VA AC
(Per module): 600 W DC, 5000 VA AC

Maximum power dissipated by user added components: 2 W

Thermal Offset < 3 μ V per channel

Closed Channel Resistance: < 2 Ω (end of relay life)

DC ISOLATION

	< (40°C, 60% RH)	< (40°C, 95% RH)
Open Channel, Channel-Channel*	> 10 ¹¹ Ω	> 10 ⁹ Ω
Channel-Chassis*	> 5x10 ¹¹ Ω	> 10 ¹⁰ Ω

(* with 1 channel closed)

AC ISOLATION/PERFORMANCE**

Capacitance:

Open Channel	< 7 pF
Channel-Channel*	< 10 pF
Channel-Chassis*	< 25 pF

(* with 1 channel closed)

(50 Ω termination)	100 kHz	1 MHz	10 MHz
Insertion Loss (dB)	< 0.20	< 0.25	< 0.50
Crosstalk (dB)	< -73	< -53	< 33

** With chassis of all equipment connected, and with low of input lines connected to low of output lines (either directly or via 3488A switched channel).

Chapter 8

44472A

Dual 4 – 1 VHF Switch Module

Introduction

This option to the 3488A (option 012) provides two independent 4 channel to one coaxial multiplexers. These multiplexers are specifically designed for broadband signal switching up to 300MHz. This module is the logical choice for wide dynamic range measurements with spectrum and distortion analyzers.

Figure 8-1 shows a simplified schematic of the two multiplexers. Notice that the two groups are isolated from each other and also from the 3488A chassis ground. This eliminates ground loops. Furthermore, the shield (or low) of each channel is NOT switched; the shields of the four channels in each group are in common. Characteristic impedance is 50 Ω .

This chapter is designed to serve as a reference guide for using the 44472A VHF Switch Module. As such it contains programming information, installation and configuration information, and application examples.

WARNING

The 3488A Option 012, 44472A VHF Switch Module uses latching relays. The state of these relays can only be altered under program control. This is an advantage in the sense that, under most conditions of failure, the relays will remain in whatever state your program has set them. However, in case of power or equipment failure, any application requiring a failsafe method of insuring that the circuits under control are in a known state must be provided by the installer.

In case of component failure or programming error, any voltage input to an option card may be present on any other terminal on the same option card.

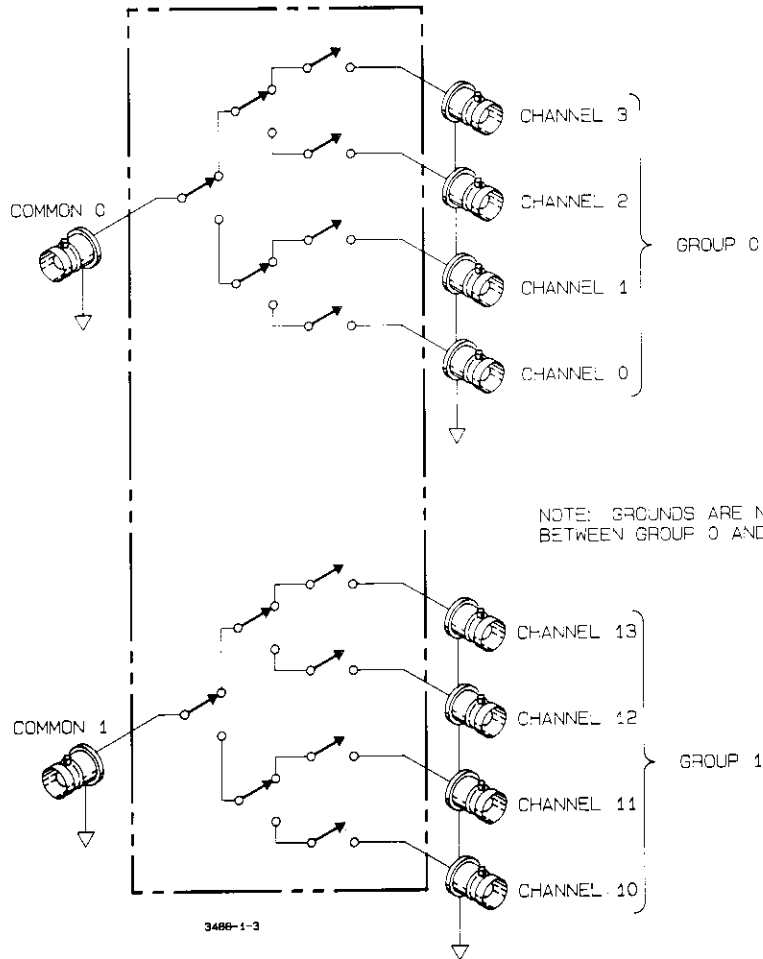

Figure 8-1. 44472A Simplified Schematic

Operation

Figure 8-1 shows that the 44472A VHF Switch Module consists of two independent 4-to-1 multiplexers. Only one channel may be connected to the common (per group) at a time. At turn on or reset (either from the front panel or the HP-IB CLEAR command), all relays on the 44472A option will be opened.

Each group on this option may be used as 1-of-4 inputs to one output or one input to 1-of-4 outputs. Connections to the option are made through 10 BNC (coaxial) connectors mounted directly on the circuit board.

Channels

A channel, as described in Chapter 2, refers to an individual set of relays on the 44472A assembly. Therefore, when we speak of closing a channel, we are referring to closing a particular set of relays, thereby connecting the common to one of the four inputs.

As shown on the terminal block (see Figure 8-1), channel numbers are two digit numbers assigned per group. The first digit is the group number (either a 0 or 1), the second digit specifies the channel in the group (0 through 3).

Channel addresses, on the other hand, are determined by which slot the 44472A assembly is installed in. Channel addresses are a three digit number where the first digit specifies the particular slot where the 44472A option is installed. The last two digits are the group/channel number. For example, channel address 102 means slot 1, group 0, and channel 2.

The following table shows the channel addressing scheme for the five different slots.

Table 8-1. Channel Addressing Scheme

Channel number as shown on the terminal block	Channel address if 44472A assembly is in slot number:				
	Slot 1	Slot 2	Slot 3	Slot 4	Slot 5
Group 0					
00	100	200	300	400	500
01	101	201	301	401	501
02	102	202	302	402	502
03	103	203	303	403	503
Group 1					
10	110	210	310	410	510
11	111	211	311	411	511
12	112	212	312	412	512
13	113	213	313	413	513

Commands

Most of the 3488A commands can be used in controlling the 44472A option. In addition to the standard 3488A commands, two HP-IB interface commands can also affect the use of the 44472A. All of these commands are described using a simple format of explanation.

In the following summary of command descriptions, square brackets ([]) indicate optional parameters, whereas items in < > brackets are mandatory. For further explanation of the command code mnemonics, refer to Chapters 2 and 3.

CLOSE a channel

Command Format: CLOSE <ch. address>[,<ch. address>,<ch. address>,...]

Description

The CLOSE command is used to simply close a channel on the 44472A. Note that the CLOSE command does not open any channels on other option assemblies that were previously closed. Only one channel per group on a 44472A option can be closed at any time. Several channels (on either a different group or option) can be closed with one CLOSE command by separating the channel addresses with a comma; channels are closed in the order listed.

Example

OUTPUT 709;''CLOSE 102,311'' ! Closes channel number 02 in slot 1 and channel number 11 in slot 3.

OPEN a channel

Command Format: OPEN <ch. address>[,<ch. address>,<ch.address>...]

Description

OPEN is used to open individual channels on the 44472A assembly. Channels are opened in the order listed. Use the CARD RESET command to open all channels on an assembly. It is easier than listing each one individually.

Examples

OUTPUT 709;''OPEN 100,112'' ! Relays 100, 112 are opened in slot number 1

VIEW a channel

Command Format: VIEW <ch. address>

Description

The VIEW command is used to look at the state (either open or closed) of a particular channel. The 3488A responds with the string "OPEN 1" if the specified channel is open. If the specified channel is closed, the 3488A responds with the string "CLOSED 0". In the 3488A display, the channel address is displayed followed by a colon and the appropriate string.

Example

```
10 OUTPUT 709;"VIEW 102"    ! VIEWs channel 2 in group 0 on slot number 1
20 ENTER 709; A$            ! input the response from the 3488A
30 DISP A$                  ! A$ will either be "OPEN 1" or "CLOSED 0"
```

CARD TYPE

Command Format: CTYPE <slot>

Description

This command causes the 3488A to respond with a description of what type of option card is located in the specified slot. The description includes the name of the card as well as the option number. In the display, the description is preceded by the specified slot number.

Card Type	Description
Slot is empty	NO CARD 00000
10 Channel Multiplexer	RELAY MUX 44470
General Purpose Card	GP RELAY 44471
High Frequency Scanner	VHF SW 44472
Matrix Card	MATRIX SW 44473
Digital I/O Card	DIGITAL IO 44474
Breadboard Card	BREADBOARD 44475

Example

```
10 OUTPUT 709;"CTYPE 3"      ! look for the card in slot 3
20 ENTER 709; A$
30 DISP A$                    ! Card description will be displayed
```

CARD RESET

Command Format: CRESET <slot>[,<slot>,...]

Description

CRESET is used to reset all channels on the 44472A assembly to their open state. Only cards in the slots specified are affected.

Example

```
OUTPUT 709;"CRESET 2"      ! resets the option assembly in slot 2
```

CARD PAIR

Command Format: CPAIR <slot>,<slot>

Description

CARD PAIR is used to pair up two option assemblies of the same type, e.g., 44472A's. This operation will effectively assign both options to both slot numbers so that closing or opening a channel on either option will perform the same operation on the respective channel on the other option.card.

Commands used with the Card PAIR function are: OPEN, CLOSE, CRESET, CHAN and STEP. Of course, paired slots can be used as part of a scan list.

Executing a CPAIR command cancels any previous CPAIR command that involved either of the two options. It is possible, however, to have two sets of card pairs, e.g. slot 1 paired with 2 and slot 3 paired with 4.

Example

```
OUTPUT 709;"CPAIR 1,3"      ! sets the options in slots 1 and 3 as pairs
OUTPUT 709;"CLOSE 102"     ! closes channels 102 and 302 simultaneously
```

Executing the CPAIR command without specifying any slot numbers allows you to determine which, if any, slots are paired together. Four numbers are returned separated by commas. The first two specify slots in the first pair, the second two numbers specify the second pair. An inactive card pair is denoted by 0,0.

Example

```
OUTPUT 709; "CPAIR"  
ENTER 709; A$  
DISP A$
```

String variable A\$ will have the four slot numbers. Note, you may have to dimension A\$ to 30 prior to executing.

SCAN LIST

Command Format: SLIST [<ch. address>(, or -)<ch.address> . . . <ch. address>]

Description

Scan List allows you to specify a sequence of channels to be scanned. The sequence is specified as a list of up to 85 channel addresses (relay or Digital I/O lines) and/or stored setups separated by commas. Contiguous channels may be specified by entering the first and last channel addresses separated by a hyphen. STEP is used to sequentially close channels in the list.

Example

```
10 OUTPUT 709:"SLIST 100-113,0; CMON 1"  
20 FOR I = 1 TO 8  
30 OUTPUT 709; "STEP"  
40 NEXT I
```

In this example, the scan would start with channel 100, proceed through the "0" group of channels and then through the "1" group of channels. The 0 channel specified at the end of the list is a stop channel and opens the last channel closed (channel 113) but does not close any other channel.

Notes

1. Channels may be scanned in any sequence, i.e., 113-100.
2. Stepping beyond the last channel specified in the Scan List causes a wrap-around to the first channel in the list. The number 0 can be used as a stop channel.

3. Refer to the Advanced Operations section in this chapter for information on using the External Trigger and Channel Closed features.

4. The commands OPEN, CLOSE, CRESET, or RECALL will have no effect on the scan list even though the state of individual channels may change.

5. Stored setups may be recalled as part of a Scan List simply by specifying the register number. For example, SLIST 100,101,102,24,120,121,122. Here, register 25 has the stored setup.

STEP Command through the Scan List

Command format: STEP

Description

STEP is used to open the last channel closed and close the next channel in the Scan List. If STEP is executed and no Scan List exists, the 3488A will generate an error.

The 3488A uses a pointer to keep track of which channel in the Scan List is currently closed. Whenever STEP is executed, that channel is opened and the next item in the list is checked. If the next item in the list is a relay or Digital I/O line, that channel is closed. If the next item in the list is a stored setup, that setup is recalled. Channels that are closed as part of a stored setup will remain closed, that is, they are not opened by the next execution of the STEP command.

For information on External Increment and Channel Closed, refer to the Advanced Operation section of this chapter.

Example

```
10 OUTPUT 709; "SLIST 100-113;CMON 1"  
20 FOR I=1 TO 10  
30 OUTPUT 709;"STEP"  
40 NEXT I
```

CHANnel Command

Command Format: CHAN [<ch. address>]

Description

CHAN is used to open the last channel closed by either STEP or CHAN (whichever was most recent) and close the specified channel. If no channel is specified with CHAN, the 3488A will respond with the last channel closed by either STEP or CHAN. If no channel has been closed since the last reset, then CHAN returns the number 0.

If a Scan List is in effect when CHAN is executed, the 3488A will search the list and position the Scan List pointer to the channel specified by CHAN. If CHAN specifies a channel that is not in the Scan List, and then STEP is executed, the 3488A will open the channel closed by CHAN and go to the beginning of the Scan List.

Examples

```
OUTPUT 709; "CHAN 100"      ! Closes channel 100
```

```
OUTPUT 709; "CHAN"
```

```
ENTER 709; A$
```

```
DISP A$                      ! A$ will contain the last channel closed, i.e., 100
```

CARD MONITOR mode

Command Format: CMON <slot>

Description

Card Monitor is used to look at the state of the individual option assemblies in the specified slot (1-5). Specifying slot 0 will cause the monitor mode to be cancelled. If a negative number is used for the slot, the 3488A will go to its monitor tracking mode.

When used to monitor the 44472A VHF Switch, the display shows the slot number (extreme left) and the two groups of channels. The two groups are separated by a semicolon. Channels that are closed are shown in the display.

Example

OUTPUT 709; "CLOSE 201,213; CMON 2"

The resulting display looks like the following photograph.

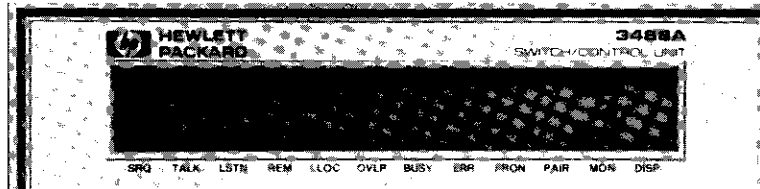

The format of the 44472A Card Monitor display can be summarized as:

s: n,n,n,n;n,n,n,n

Where s represents the slot number being monitored and n is a one digit channel number. The four channels to the left of the semicolon represent group 0, the four channels to the right are for group 1.

Advanced Operations

Advanced Operations provide you with more capabilities when using the 3488A. It may be important, for example, to tell the system voltmeter when a channel has been closed and thus take a measurement. Or maybe you need to close the next channel in a scan list when some external event has taken place, perhaps as soon as the voltmeter has completed its reading. Most operations can be performed with only the basic commands, but for those times when you need something more, the advanced operations should meet your switching needs.

External Increment and Channel Closed

External Increment (EI) provides a method of sequencing through a Scan List without system computer intervention. Typically, EI is connected to the Voltmeter Complete* output on a system voltmeter. Thus, when the voltmeter has completed its measurement, it signals the 3488A to step to the next channel in the list. The EI input is rising-edge triggered and TTL compatible.

* Voltmeter Complete is a feature found on most Hewlett-Packard digital voltmeters to signal the completion of a measurement by means of a TTL compatible pulse.

Channel Closed (CC) provides a 15 μ S TTL pulse for signalling when a channel has been closed in the 3488A. This signal can be tied to the External Trigger input of a voltmeter to trigger it when a channel is closed. Together, EI and CC can be used with a system voltmeter to sequence through a scan list without any intervention by the system computer.

Using the External Increment and Channel Closed features requires the use of a 44474A Digital I/O option. This also means that the Digital I/O option cannot be configured in handshake mode when it is used for scanning (it can be used statically, however). The DMODE command is used to specify the Handshake Mode, Polarity, and EI. Only one Digital I/O option can be configured for EI at a time. If one option is configured to accept EI and another is subsequently enabled, the first card will be disabled.

Even though the only specifier we are interested in is EI, the mode and polarity specifiers must be included. The format for specifying DMODE is as follows:

DMODE <slot>[, <mode>][, <polarity>][, <EI>]

The MODE specifier is as follows:

Definition	Value
Static Mode	1
Static Mode for read back	2
R/W & Strobe	3
Rd & Wrt Strobe	4
Handshake (no EI)	5

Any of the Modes may be specified for use with External Increment except the Handshake Mode (value 5).

The Polarity specifier is the sum of weighted values and is defined as follows:

Definition	Value
Lower 8-bits polarity	1 = Low true
Upper 8-bits polarity	2 = Low true
PCTL Polarity	4 = Low busy
PFLG Polarity	8 = Low busy
I/O Direction line Polarity	16 = Low input mode

EI is enabled by specifying 1. It is disabled with a specifier of 0.

DELAY

DELAY [<time in mS>]

Description

The DELAY command is used to insert a time delay between the time that a channel is closed and the time the next command can be executed and the channel closed pulse is output. The delay time may be specified from 0 to 32,767 mS (32.767 seconds) in 1 mS increments. The delay time does not become effective until either CHAN or STEP is executed.

If any command is sent to the 3488A during the delay time, the command will be executed as soon as the delay time is complete. If there is not a time value specified with the DELAY command, the 3488A will respond with the current value of the delay time.

Remember that the Channel Closed pulse will use whichever 44474A assembly has External Increment enabled.

Examples

OUTPUT 709; "DELAY 45" ! The delay time is 45 mS = .045 Sec.

OUTPUT 709; "DELAY"

ENTER 709; A

DISP A ! Variable 'A' will show the current delay value.

HP-IB Interface Commands

Only two interface commands affect the state of the 44472A channels: TRIGGER (Group Execute Trigger) and CLEAR (Device Clear or Selected Device Clear). TRIGGER performs the same function as the 3488A STEP command. In other words, the two commands:

TRIGGER 7 (or TRIGGER 709)

and

OUTPUT 709; "STEP"

perform the same function as far as the 44472A assembly is concerned.

CLEAR, whether a Device Clear or Selected Device Clear, simply resets the 3488A and hence all relays will go to their open state.

44472A Assembly Installation

This portion of the chapter is written specifically for the service trained technician. It provides the necessary information for a person trained in electronic circuitry to configure and install the option assembly. Carefully read through this section and adhere to all cautions and warnings.

WARNING

Only qualified service trained personnel should remove, configure, or install the 3488A option assemblies. Disconnect the 3488A power cord from the back of the instrument prior to installing the option assemblies.

The 3488A Option 011, 44472A VHF Switch uses latching relays. The state of these relays can only be altered under program control. This is an advantage in the sense that, under most conditions of failure, the relays will remain in whatever state your program has set them. However, in case of power or equipment failure, any application requiring a failsafe method of insuring that the circuits under control are in a known state must be provided by the installer.

In case of component failure or programming error, any voltage input to an option card may be present on any other terminal on the same option card.

When you initially received your 3488A, the option assemblies were not installed in the mainframe. Each option assembly was packaged separately along with a terminal block edge connector and a two piece strain relief housing. In addition, two labels were provided for option identification.

CAUTION

Use clean handling and anti-static procedures when removing, configuring and installing the option assemblies. The circuit boards must be kept clean to ensure compliance with impedance specifications. The option assemblies as well as the 3488A mainframe contains CMOS devices which are susceptible to static discharges.

A few simple steps are required to install the 44472A assembly. Carefully observe to orientation of the assembly and terminal block as you install them.

1. Pre-installation

- a. Remove the ac power cord from the 3488A before installing any option assembly.
- b. Position the rear panel of the 3488A toward you.
- c. Select a slot. Refer to Figure 8-2, the 3488A has five slots for installing option assemblies. The 44472A can be used in any of the five slots.

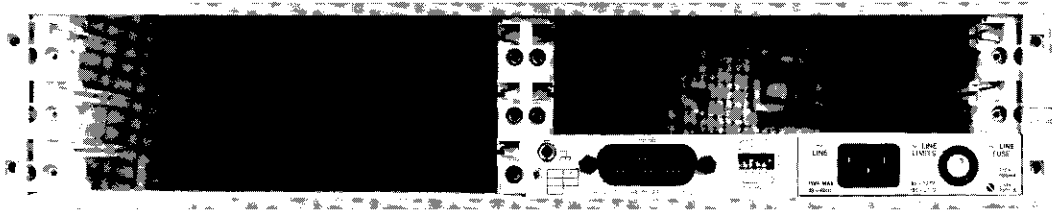

Figure 8-2. Rear Panel View of the 3488A

2. Option assembly installation

- a. Hold the option assembly, component side down, by the metal shields. Insert the circuit card into the slot guides and slide toward the front of the instrument. Push firmly until the assembly 'snaps' into place. Tighten the two side screws to hold the option in place.
- b. A series of five numbered labels (1 to 5) were provided with the option assembly. Select the number that indicates which 3488A slot you have installed the option in and place the sticker in the upper left hand corner of the option backpanel.

Specifications

The specifications at the end of this chapter apply to only the 44472A assembly. These specifications are the performance standards or limits against which the assembly is tested. Do not exceed or surpass the specified limits.

Any changes in specifications due to manufacturing changes, design, or traceability to the National Bureau of Standards will be covered in a manual change supplement.

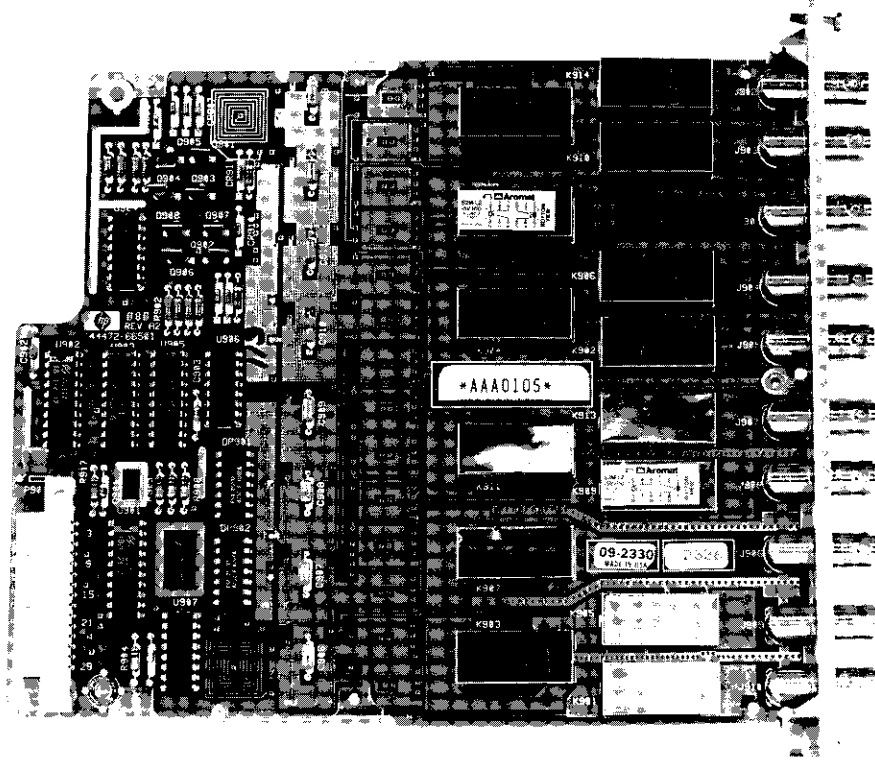

Figure 8-3. Option Card

Applications

There are many conceivable applications for the 44472A VHF Switch, many of which are not as obvious as others. It is definitely the right choice if you are switching signals in the 10 – 300 MHz range. Switching low frequency signals, in the audio range for example, you could use either the 44472A VHF Switch or the 44470A Multiplexer. The 44472A is not recommended for instruments that require high DC isolation from earth ground (such as a DVM).

Your choice should depend on your application.

Isolation Impedance

The 44472A option is a VHF switch having excellent on channel to off channel isolation over a bandwidth of dc to 300 MHz. This makes it possible to switch signals to instruments with very high bandwidths and not have adjacent channel interference. The adjacent channel interference is typically a driven signal but may also be broadband noise picked up on the wiring to these channels.

Note also that for each group of four channels on the 44472A VHF switch, when all channels have been opened, the last channel to open in each group will exhibit approximately 20 dB less isolation than the other three channels in that group. Refer to the specifications at the end of this chapter. At power-on or reset, the last channel closed in group 0 is channel 00; in group 1, the last channel closed is 13.

Topologies

Two 1-to-4 VHF Multiplexers are provided on each 44472A module. These can be used independently, together, or in combination with other 44472A options. There are, however, trade-offs that must be considered.

Regardless of the topology (configuration) you are using, always use 50 Ω shielded coaxial cables to maintain both characteristic impedance and isolation. Keep cables as short as possible, especially in high frequency circuits or pulse circuits where a rise/fall time of <50nS is critical. Long cables can add considerable delay time which may cause timing problems. All test equipment; such as counters, spectrum analyzers, oscilloscopes, etc., must be terminated with a 50 Ω impedance to minimize reflection loss.

Figure 8-4 shows both multiplexers from one 44472A module connected together in a "T" configuration. This circuit provides a 1-of-8 multiplexer. VSWR becomes important here because the characteristic impedance of 50 Ω is lost. Considerable reflection may be present and could cause double triggering in counters, etc. This configuration should not be used with very narrow pulses or pulses with rise/fall times of 20nS or less.

The correct way to connect multiple 1 – of – 4 modules is shown in Figures 8-6 and 8-7. A general rule to keep in mind is never use BNC "T" connectors if full bandwidth performance is needed. Anytime a BNC "T" is used, VSWR will not be maintained in the test system.

One simple way to provide a simple 1 – of – 4 to 1 – of – 4 matrix is to connect the common connectors on two channel groups together, as shown in Figure 8-5. This configuration provides an excellent method of connecting four devices under test to four different test instruments and maintains the 50 Ω characteristic impedance.

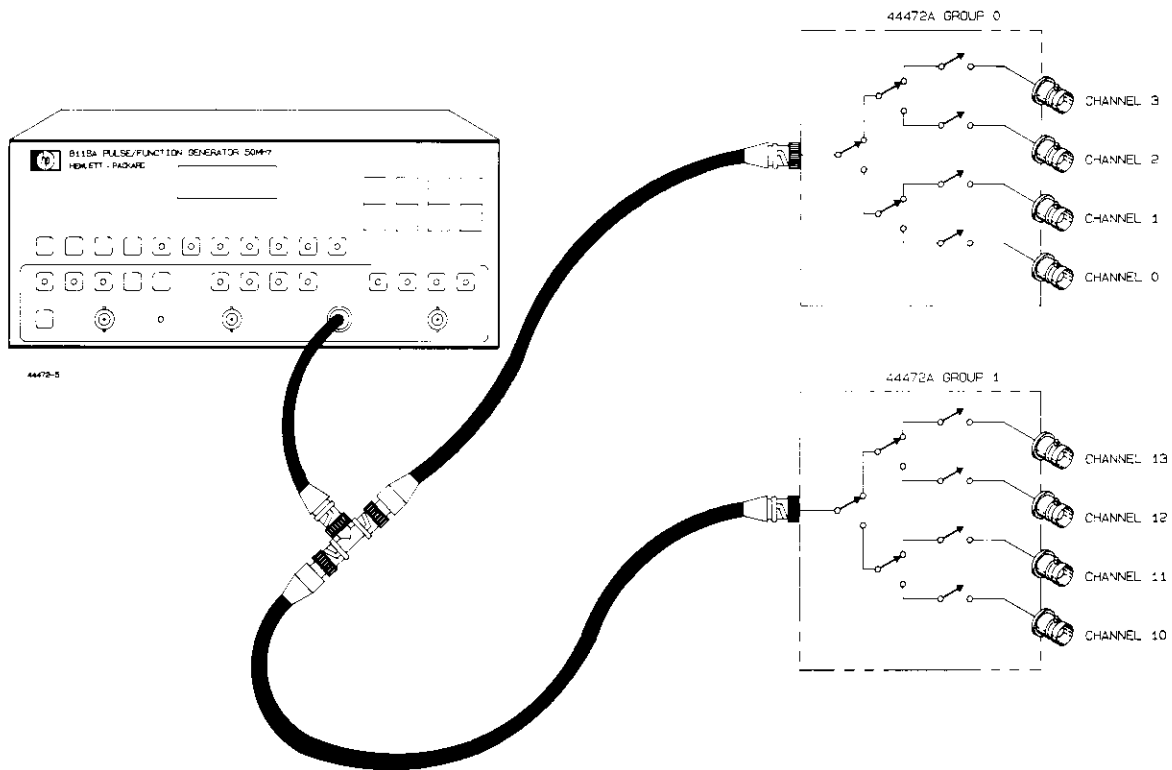

Figure 8-4. Two 44472A's in "T" Configuration

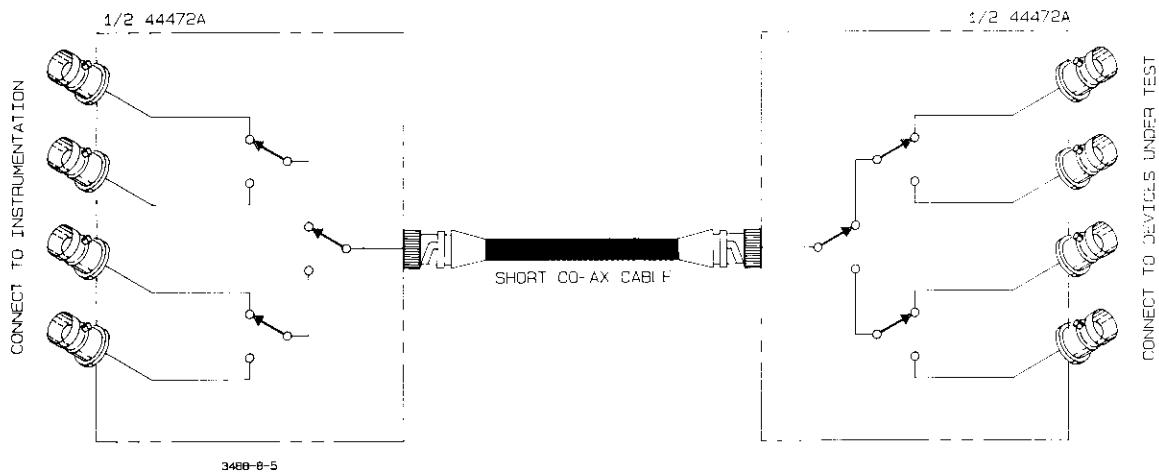

Figure 8-5. 4x4 Matrix

A tree configuration, like that shown in Figure 8-6, provides complete isolation while maintaining the 50 Ω characteristic impedance. It also provides 16 channels for test points. Again, keep cable length as short as possible especially between channel groups. Signal delay time has doubled because the signal must pass through two channel groups.

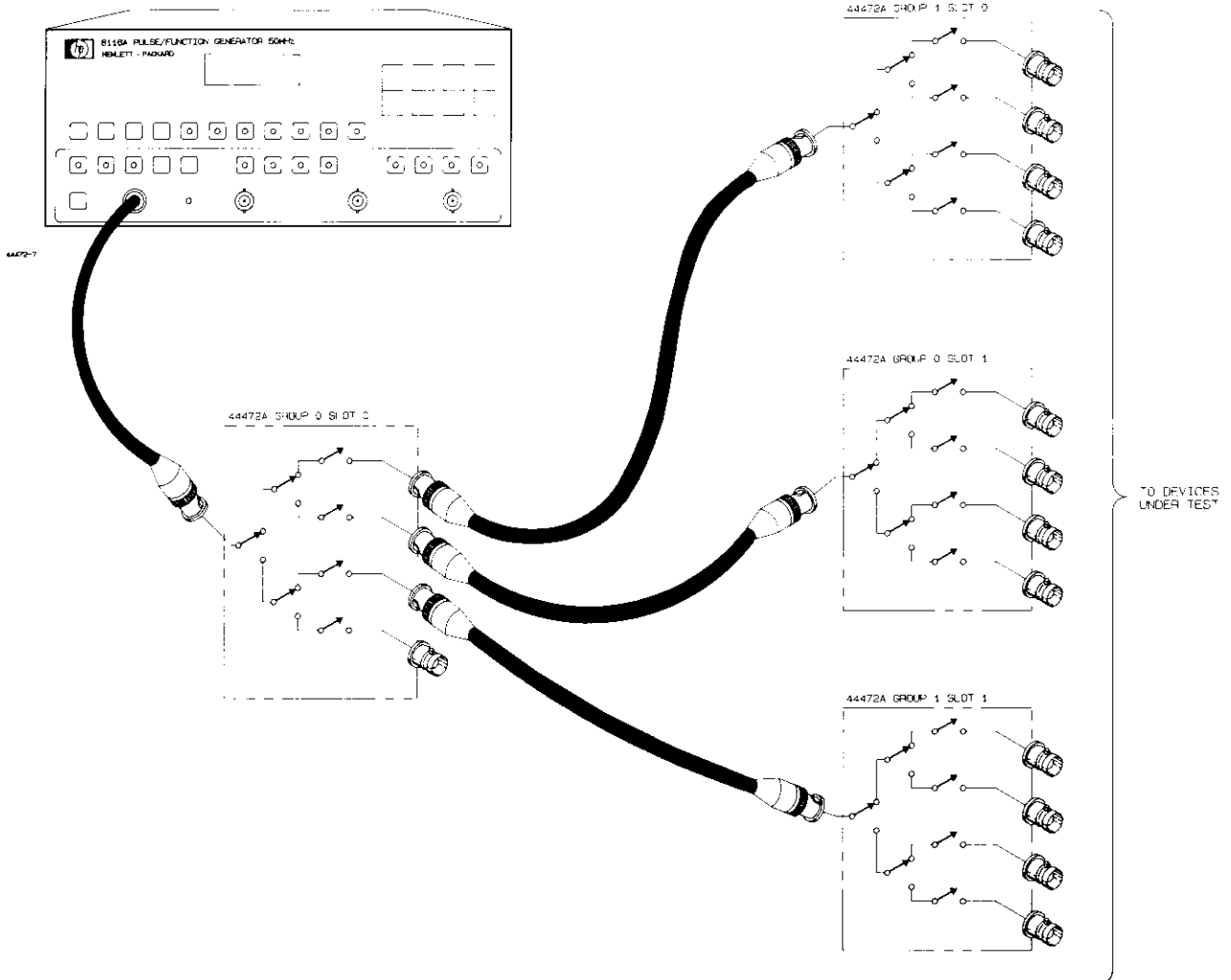

Figure 8-6. Tree Configuration

Table 8-2. Option 012 44472A Dual 4 Channel VHF Switch Module Specifications

INPUT CHARACTERISTICS

Maximum Voltage (Center-center, center-low): 250 VDC,
30 VAC RMS, 42 VAC Peak*; (Low-chassis, low-low): 42 VDC

Maximum Current (Per channel): 30 mA DC, 300 mA AC RMS*

Thermal Offset: < 15 μ V per channel

Characteristic Impedance: 50 Ω

Closed Channel Resistance: < 1 Ω (end of relay life)

*To maintain compliance with VDE class B or FTZ 1115:83 radiation limits, use semi-rigid or equivalent coax cable and limit signal to < 2x10⁷ V*Hz.

AC ISOLATION/PERFORMANCE

(50 Ω termination)	30 MHz	100 MHz	300 MHz
Insertion Loss (dB)	< 0.5	< 0.75	< 1.25
Crosstalk (dB) Channel-Channel, Channel-Common	< 100	< 85	< -65
VSWR	< 1.06	< 1.12	< 1.43

Capacitance: Center-Center, Center-Common < 0.002 pF
Center-Low < 70 pF
Low Chassis < 0.2 μ F

Rise Time: < 0.7 nsec

Signal Delay: < 2.5 nsec; Channel match < 90 psec

DC ISOLATION

<(40°C, 95% RH), between any 2 points: > 10⁷ Ω

GENERAL

All channels break-before make within a group of 4 channels. When all channels in a group are opened, the last channel opened (or channel 00 or 13 following a group RESET) has channel-common isolation of > 80 dB @ 30 MHz, > 60 dB @ 100 MHz, & > 40 dB @ 300 MHz.

Connectors: BNC's

Chapter 9

44473A

4×4 Matrix Switch Module

Introduction

-hp- Model 44473A (3488A option 013) Matrix Switch provides a 4 – by – 4 matrix of switches. Each node or crosspoint in the matrix switches both signal Hi and Lo (2 wires). Refer to Figure 9-1 for a simplified schematic of the module.

Matrix switching provides a convenient way to connect a group of test instruments to multiple test points on a device or to multiple devices. This matrix switch offers highly flexible switching for testing devices over a frequency range of DC to 100 kHz.

Any combination of the 4 “inputs” (e.g., rows) may be connected any combination of “outputs” (e.g., columns). Multiple 44473A options may be connected together to form a 4×8 , 4×12 , 4×16 , 4×20 or 8×8 matrix. In addition, the Matrix option can be used in conjunction with other options (such as the 44470A ten channel Multiplexer) to provide a wide variety of switching combinations.

This chapter is designed to serve as a reference guide for using the 44473A Matrix Switch option. As such, it contains programming information, installation and configuration information, and application examples.

WARNING

The 3488A option 013 Matrix Switch uses latching relays. The state of these relays can only be altered under program control. This is an advantage in the sense that, under most conditions of failure, the relays will remain in whatever state your program has set them. However, in case of power or equipment failure, any application requiring a failsafe method of insuring that the circuits under control are in a known state must be provided by the installer.

In case of component failure or programming error, any voltage input to an option card may be present on any other terminal on the same option card.

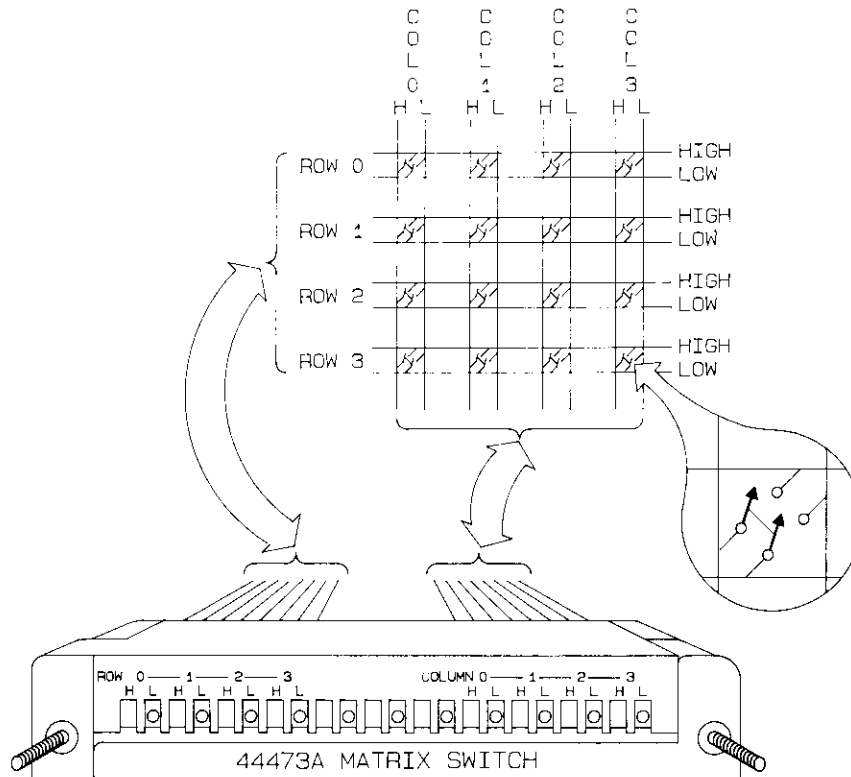

348B-1-4

Figure 9-1. 44473A Simplified Schematic

Operation

Figure 9-1 shows that the 44473A Matrix Switch option consists of sixteen 2-wire relays connected in a 4 × 4 matrix. More than one switch can be closed at a time allowing any combination of rows connected to columns. At turn on or reset (either reset from the 3488A front panel or from the HP-IB CLEAR command) all relays will be opened.

Channels

A channel, as described in Chapter 2, refers to an individual relay in the matrix. Therefore, when we speak of closing a channel, we are referring to closing a particular relay. Channel numbers are specified as a two digit number, XY, where X represents the row (0–3) and Y represents the column (0–3) where the relay resides. These channel numbers are repeated on each 44473A option and can be seen by the numbering on the terminal block.

Channel addresses, on the other hand, are determined by which slot the 44473A assembly is mounted in. Channel addresses are a three digit number where the first digit specifies the particular slot where the 44473A option is installed. The last two digits are the row/column channel number. For example, channel address 102 means the option is installed in slot #1; the relay is in row 0, column 2.

The following chart shows the channel addressing scheme for the five different slots.

Table 9-1. Channel Addressing Scheme

Channel number (Row-Column)	Channel address if 44473A assembly is in slot number:				
	Slot 1	Slot 2	Slot 3	Slot 4	Slot 5
00	100	200	300	400	500
01	101	201	301	401	501
02	102	202	302	402	502
03	103	203	303	403	503
10	110	210	310	410	510
11	111	211	311	411	511
12	112	212	312	412	512
13	113	213	313	413	513
20	120	220	320	420	520
21	121	221	321	421	521
22	122	222	322	422	522
23	123	223	323	423	523
30	130	230	330	430	530
31	131	231	331	431	531
32	132	232	332	432	532
33	133	233	333	433	533

Commands

Most of the 3488A commands have an impact on the 44473A assembly. In addition to the standard 3488A commands, two HP-IB interface commands can also affect the use of the 44473A. All of these commands are described using a simple format of explanation.

In the following summary of command descriptions, square brackets ([]) indicate optional parameters, whereas items in < > brackets are mandatory. For further explanation of the command code mnemonics, refer to Chapters 2 and 3.

CLOSE a channel

Command Format: CLOSE <ch. address>[,<ch. address>,<ch. address>,...]

Description

The CLOSE command is used to simply close one or more channels on the 44473A. Note that the CLOSE command does not open any channels that were previously closed. Several channels can be closed with one close command by separating the channel addresses with a comma. Channels are closed in the order listed.

Examples

OUTPUT 709;''CLOSE 100,102,103'' ! Closes channels 00, 02, and 03 in slot number 1

OUTPUT 709;''CLOSE 102,301'' ! Closes channel number 02 in slot 1 and channel number 01 in slot 3.

OPEN a channel

Command Format: OPEN <ch. address>[,<ch. address>,<ch.address>...]

Description

OPEN is used to open individual channels on the 44473A assembly. If more than one channel is specified in the OPEN list, they will be opened in the order listed. Use the CARD RESET command to open all relays on an assembly. It is easier than listing each channel individually.

Examples

OUTPUT 709;''OPEN 100,102,103'' ! Relays 00, 02, and 03 are opened in slot number 1

VIEW a channel

Command Format: VIEW <ch. address>

Description

The VIEW command is used to look at the state (either open or closed) of a particular channel. The 3488A responds with the string "OPEN 1" if the specified channel is open. If the specified channel is closed, the 3488A responds with the string "CLOSED 0". In the 3488A display, the channel address is displayed followed by a colon and the appropriate string.

Example

```
10 OUTPUT 709;"VIEW 102"    ! VIEWs channel 2 on slot number 1
20 ENTER 709; A$            ! input the response from the 3488A
30 DISP A$                  ! A$ will either be "OPEN 1" or "CLOSED 0"
```

CARD TYPE

Command Format: CTYPE <slot>

Description

This command causes the 3488A respond with a description of what type of option card is located in the specified slot. The description includes the name of the card as well as the option number. In the display, the description is preceded by the specified slot number.

Card Type	Description
Slot is empty	NO CARD 00000
10 Channel Multiplexer	RELAY MUX 44470
General Purpose Card	GP RELAY 44471
High Frequency Scanner	VHF SW 44472
Matrix Card	MATRIX SW 44473
Digital I/O Card	DIGITAL IO 44474
Breadboard Card	BREADBOARD 44475

Example

```
10 OUTPUT 709;"CTYPE 3"      ! look for the card in slot 3
20 ENTER 709; A$
30 DISP A$                    ! Card description will be displayed
```

CARD RESET

Command Format: CRESET <slot>[, <slot>, ...]

Description

CRESET is used to reset all channels on the 44473A assembly to their open state. Only cards in the slots specified are affected.

Example

```
OUTPUT 709;"CRESET 2"      ! resets the option assembly in slot 2
```

CARD PAIR

Command Format: CPAIR <slot>, <slot>

Description

CARD PAIR is used to pair up two option assemblies of the same type, e.g., 44473A's. This operation will effectively assign both options to both slot numbers so that closing or opening a channel on either option will perform the same operation on the respective channel on the other option.

Commands used with the Card PAIR function are: CLOSE, OPEN, CRESET, CHAN and STEP. Of course, paired slots can be used as part of a scan list.

Executing a CPAIR command cancels any previous CPAIR command that involved either of the two options. It is possible, however, to have two sets of card pairs, e.g. slot 1 paired with 2 and slot 3 paired with 4.

Example

```
OUTPUT 709;"CPAIR 1,3"      ! sets the options in slots 1 and 3 as pairs
OUTPUT 709;"CLOSE 102"     ! closes channels 102 and 302 simultaneously
```

Executing the CPAIR command without specifying any slot numbers allows you to determine which, if any, slots are paired together. Four numbers are returned separated by commas. The first two numbers specify slots in the first pair, the second two numbers specify the second pair. An inactive card pair is denoted by 0,0.

Example

```
OUTPUT 709; "CPAIR"  
ENTER 709; A$  
DISP A$
```

String variable A\$ will have the four slot numbers. Note, you may have to dimension A\$ to 30 prior to executing.

SCAN LIST

Command Format: SLIST [<ch. address>(, or -)<ch.address>.<ch. address>]

Description

Scanning allows you to specify a sequence of channels to be scanned. The sequence is specified as a list of up to 85 channel addresses (relay or Digital I/O lines) and/or stored setups separated by commas. Contiguous channels may be specified by entering the first and last channel addresses separated by a hyphen. STEP is used to sequentially close channels in the list.

Example

```
10 OUTPUT 709; "SLIST 100-133,0;CMON 1"  
20 FOR I = 1 TO 16  
30 OUTPUT 709; "STEP"  
40 NEXT I
```

In this example, the scan would start with channel 100 and proceed through each column on row 0. The scan would then move to row 1 and sequence through each column. Next would come row 2 and sequence through each column, followed by row 3, each column. The 0 channels specified at the end of the scan list is a stop channel and opens the last relay closed (channel 133) but does not close any other channel.

Notes

1. Channels may be scanned in any sequence, i.e., 133-100.
2. Stepping beyond the last channel specified in the Scan List causes a wrap-around to the first channel in the list. The number 0 can be used as a stop channel.
3. Refer to the Advanced Operation section in this chapter for information on using the External Trigger and Channel Closed features.
4. The commands OPEN, CLOSE, CRESET, or RECALL will have no effect on the scan list even though the state of individual channels may change.
5. Stored setups may be recalled as part of a Scan List simply by specifying the register number. For example, SLIST 100,101,102,25,120,121,122. Here, register 25 has the stored setup.

STEPping through the Scan List

Command Format: STEP

Description

STEP is used to open the last channel closed and close the next channel in the Scan List. If STEP is executed and no Scan List exists, the 3488A will generate an error.

The 3488A uses a pointer to keep track of which channel in the Scan List is currently closed. When STEP is executed, that channel is opened and the next item in the list is checked. If the next item in the list is a relay or Digital I/O line, that channel is closed. If the next item in the list is a stored setup, that setup is recalled. Channels that are closed as part of a stored setup will remain closed, that is, they are not opened by the next execution of the STEP command.

For information on External Increment and Channel Closed, refer to the Advanced Operation section of this chapter.

Example

```
10 OUTPUT 709; "SLIST 100-133; CMON 1"  
20 FOR I=1 TO 10  
30 OUTPUT 709; "STEP"  
40 NEXT I
```

CHANnel Command

Command Format: CHAN [<ch. address>]

Description

CHAN is used to open the last channel closed by either STEP or CHAN (whichever was most recent) and close the specified channel. If no channel is specified with CHAN, the 3488A will display and output to the interface the last channel closed by either STEP or CHAN. If no channel has been closed since the last reset, then CHAN returns the number 0.

If a Scan List is in effect when CHAN is executed, the 3488A will search through the list and position the Scan List pointer to the channel specified by CHAN. If the channel specified by CHAN is not in the Scan List, and then STEP is executed, the 3488A will open the channel closed by CHAN and then go to the beginning of the Scan List.

Examples

OUTPUT 709; "CHAN 100" ! Closes channel 100

OUTPUT 709; "CHAN"

ENTER 709; A\$

DISP A\$! A\$ will contain the last channel closed, i.e., 100

CARD MONITOR mode

Command Format: CMON <slot>

Description

Card Monitor is used to look at the state of the individual option assemblies in the specified slot (1 – 5). Specifying slot 0 will cause the monitor mode to be cancelled. If a negative number is used for the slot, the 3488A will go to its monitor tracking mode.

There are two types of monitoring displays for the 44473A Matrix option: monitoring Rows and monitoring Columns. A total of eight displays are possible, one for each of the four rows and four columns. When initially entering the Card Monitor mode, the 3488A display will show which columns have a channel closed in Row 0. Use the front panel arrow keys to change to other displays. The following sequence of displays show how the same 44473A Matrix option can be monitored after executing the commands: CLOSE 301,303,323;CMON 3. The slot number is always shown at the far left.

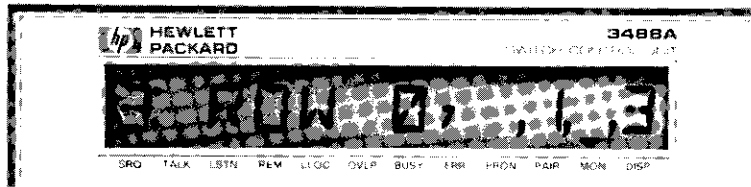

Slot 3, Row 0 in Columns 1 and 3 are closed.

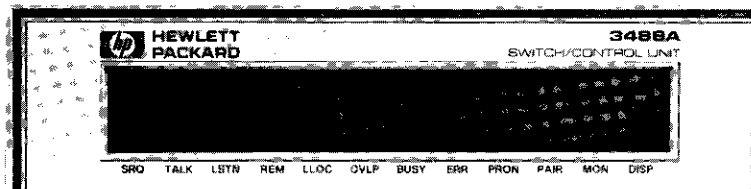

Slot 3, Row 2 in Column 3 is closed

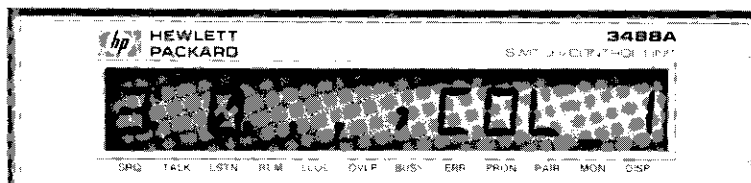

Slot 3, (Row) 0 in Column 1 is closed

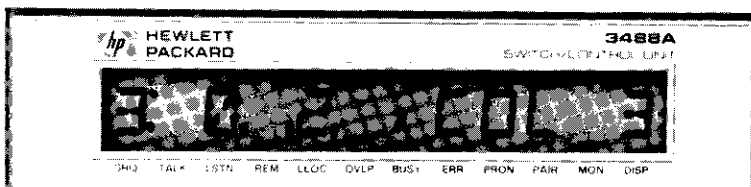

Slot 3, (Rows) 0 and 2 in Column 3 are closed

* Voltmeter Complete is a feature found on most Hewlett-Packard digital voltmeters that signal the completion of a measurement by means of a TTL compatible pulse.

Advanced Operations

Advanced Operations provide you with more capabilities when using the 3488A. It may be important, for example, to tell the system voltmeter when a channel has been closed and thus take a measurement. Or maybe you need to close the next channel in a scan list when some external event has taken place, perhaps as soon as the voltmeter has completed its reading. Most operations can be performed with only the basic commands, but for those times when you need something more, the advanced operations should meet your switching needs.

External Increment and Channel Closed

External Increment (EI) provides a method of sequencing through a Scan List without system computer intervention. Typically, EI is connected to the Voltmeter Complete* output on a system voltmeter. Thus, when the voltmeter has completed its measurement, it signals the 3488A to step to the next channel in the list. The EI input is rising-edge triggered and TTL compatible.

Channel Closed (CC) provides a 15 μ S TTL pulse for signalling when a channel has been closed in the 3488A. This signal can be tied to the External Trigger input of a voltmeter to trigger it when a channel is closed. Together, EI and CC can be used with a system voltmeter to sequence through a scan list without any intervention by the system computer. Later in this manual, Example Number 3 will show how this can be done.

Using the External Increment and Channel Closed features requires the use of a 44470A Digital I/O option. This also means that the Digital I/O option cannot be configured in Handshake Mode #5 when it is used for scanning (it can be used statically, however). The DMODE command is used to specify the handshake mode, Polarity and EI. Only one Digital I/O option can be configured for EI at a time. If one option is configured to accept EI and another is subsequently enabled, the first card will be disabled.

Even though the only specifier we are interested in is EI, the mode and polarity specifiers must be included. The format for specifying DMODE is as follows:

```
DMODE <slot>[, <mode>][, <polarity>][, <EI>]
```

The MODE specifier is as follows:

Definition	Value
Static Mode	1
Static Mode for read back	2
R/W & Strobe	3
Rd & Wt Strobe	4
HAndshake (no EI)	5

Any of the Modes may be specified for use with External Increment except the Handshake Mode.

The Polarity specifier is the sum of weighted values and is defined as follows:

Definition	Value
Lower 8-bits polarity	1 = Low true
Upper 8-bits polarity	2 = Low true
PCTL Polarity	4 = Low busy
PFLG Polarity	8 = Low busy
I/O Direction line Polarity	16 = Low input mode

EI is enabled by specifying 1. It is disabled with a specifier of 0.

DELAY

Command Format: DELAY [<time in mS>]

Description

The DELAY command is used to insert a time delay between the time that a channel is closed and the time the next command can be executed and the channel closed pulse is output. The delay time may be specified from 0 to 32,767 mS (32.767 seconds) in 1 mS increments. The delay time does not become effective until either STEP or CHAN is executed.

If any command is sent to the 3488A during the delay time, the command will be executed as soon as the delay time is complete. If there is not a time value sent with the DELAY command, the 3488A will respond by displaying the current value of the delay time.

Remember that the Channel Closed pulse will use whichever 44474A assembly has External Increment enabled.

Examples

```
OUTPUT 709; "DELAY 45"    ! The delay time is 45 mS = .045 Sec.
```

```
OUTPUT 709; "DELAY"
```

```
ENTER 709; A
```

```
DISP A                    ! Variable 'A' will show the current delay value
```

HP-IB Interface Commands

Only two interface commands affect the state of the 44473A channels: TRIGGER (Group Execute Trigger) and CLEAR (Device Clear or Selected Device Clear). TRIGGER performs the same function as the 3488A STEP command. In other words, the two commands:

TRIGGER 7 (or TRIGGER 709)

and

OUTPUT 709; "STEP"

perform the same function as far as the 44473A assembly is concerned.

CLEAR, whether a Device Clear or Selected Device Clear, simply resets the 3488A and hence all relays will go to their open state.

44473A Assembly Installation

This portion of the chapter is written specifically for the service trained technician. It provides the necessary information for a person trained in electronic circuitry to configure and install the option assembly. Carefully read through this section and adhere to all cautions and warnings.

WARNING

Only qualified service trained personnel should remove, configure, or install the 3488A option assemblies. Disconnect the 3488A power cord from the back of the instrument prior to installing the option assemblies.

The 3488A Option 011,44473ARelay Multiplexer, uses latching relays. The state of these relays can only be altered under program control. This is an advantage in the sense that, under most conditions of failure, the relays will remain in whatever state your program has set them. However, in case of power or equipment failure, any application requiring a failsafe method of insuring that the circuits under control are in a known state must be provided by the installer.

In case of component failure or programming error, any voltage input to an option card may be present on any other terminal on the same option card.

When you initially received your 3488A, the option assemblies were not installed in the mainframe. Each option assembly was packaged separately along with a terminal block edge connector and a two piece strain relief housing. In addition, two labels were provided for option identification.

CAUTION

Use clean handling and anti-static procedures when removing, configuring and installing the option assemblies. The circuit boards must be kept clean to ensure compliance with impedance specifications. The option assemblies as well as the 3488A mainframe contains CMOS devices which are susceptible to static discharges.

A few simple steps are required to install the 44473A assembly. Carefully observe the orientation of the assembly and terminal block as you install them.

1. Pre-installation

- a. Remove the ac power cord from the 3488A before installing any option assembly.
- b. Face the rear panel of the 3488A toward you.
- c. Select a slot. Refer to Figure 9-2, the 3488 has five slots for installing option assemblies. The 44473A can be used in any of the five slots.

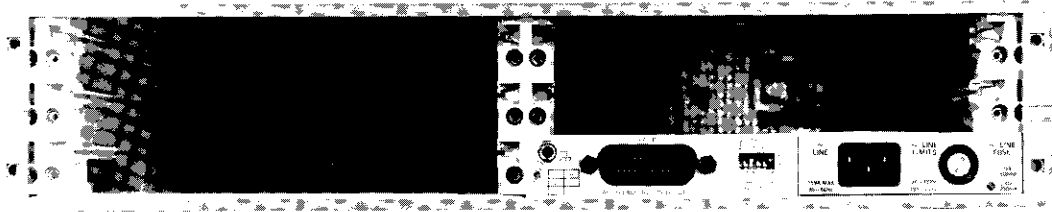

Figure 9-2. Rear Panel View of the 3488A

2. Option assembly installation

- a. Hold the option assembly, component side down, by the metal shields. Insert the circuit card into the slot guides and slide toward the front of the instrument. Push firmly until the assembly 'snaps' into place. Fold the plastic levers next to the assembly. These levers lock the option into the mainframe.

NOTE

To remove the option assembly, simply unfold the plastic tab levers. This will release the locking mechanism and pull the option out of the mainframe connector.

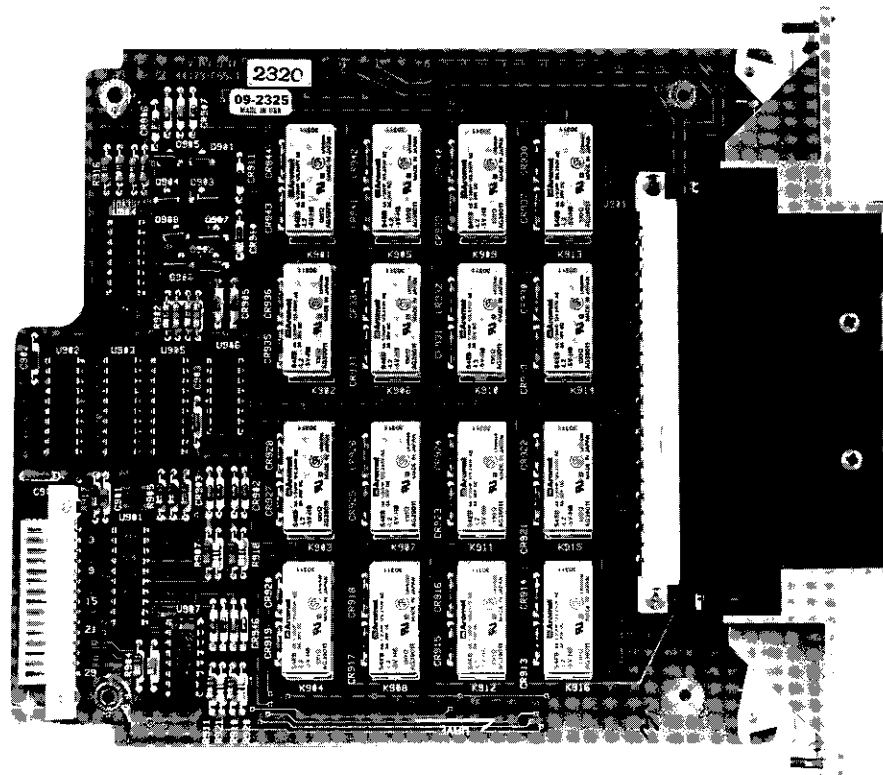

Figure 9-3. Option Card

3. Terminal Block Wiring

a. Wire the Terminal Block Edge Connector. The following photograph shows the channel connection sequence for the 44473A Terminal Block Edge Connector. This terminal block is keyed to fit only the 44473A assembly. Extra terminal blocks are available under the -hp- part number 44483A.



Figure 9-4. Terminal Block

4. Strain Relief

a. Secure the terminal block to the strain relief housing with the captive screws on the terminal block. Make certain that the screws used to tighten the connector wires to the terminal block are accessible through the strain relief housing.

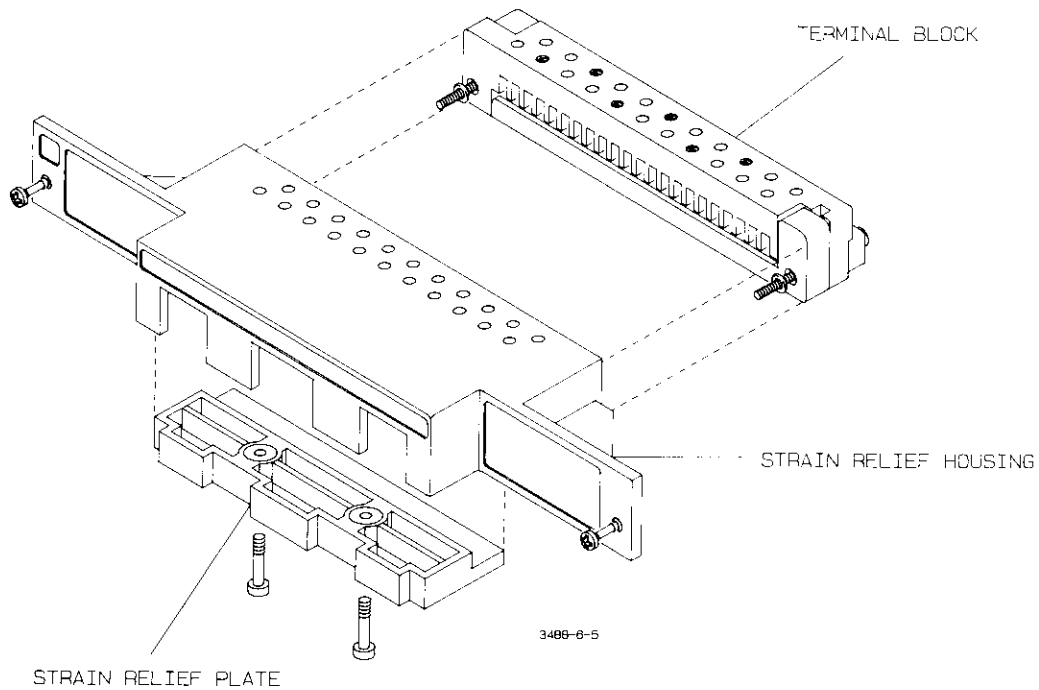

Figure 9-5. Strain Relief Assembly

b. Route the wires evenly through the three strain relief cutouts. This will ensure a uniform amount of strain relief. If only a few wires are used, they should go through the middle cutout.

c. To protect wires smaller than 22AWG it is recommended that these wires be bundled together starting no more than 4" from the back of the 3488A. Failure to do so may cause wires to break at the strain relief. To illustrate the need for this, a 26AWG wire can survive about 7 to 8 pounds of tension before breaking. A bundle of 10, however, could survive up to 70 pounds of tension.



Figure 9-6. Cable Routing

d. Secure the strain relief plate to the strain relief housing (ribbed side down). Do not over tighten the screws.

5. Labels

- a. Two labels were provided with the option assembly. One identifies the assembly as a 44473A Matrix Switch. There is space on the bottom of this label to type or write in a description of where this particular option is being used.
- b. Second, a series of numbered labels (1 to 5) is provided to help you identify the slot where the assembly is located. Select the appropriate numbered label and place it in the upper left hand corner of the strain relief housing.

Accessories

-hp- part number 44483A provides an extra Screw Terminal Connector Block for the 44473A assembly.

Specifications

The specifications at the end of this chapter apply to only the 44473A assembly. These specifications are the performance standards or limits against which the assembly is tested. Do not exceed or surpass the specified limits.

Any changes in specifications due to manufacturing changes, design, or traceability to the National Bureau of Standards will be covered in a manual change supplement.

Applications

Example 1. Extending the Matrix

Earlier in this manual it was stated that multiple 444703A Matrix options can be combined to form matrices of 4×8 , 4×12 , 4×16 , 4×20 and 8×8 . The purpose of this example is to show how these matrices are constructed. Figures 9-7 through 9-11 show the various configurations.

When wiring between option cards, keep wire length as short as possible to minimize noise and signal degradation.

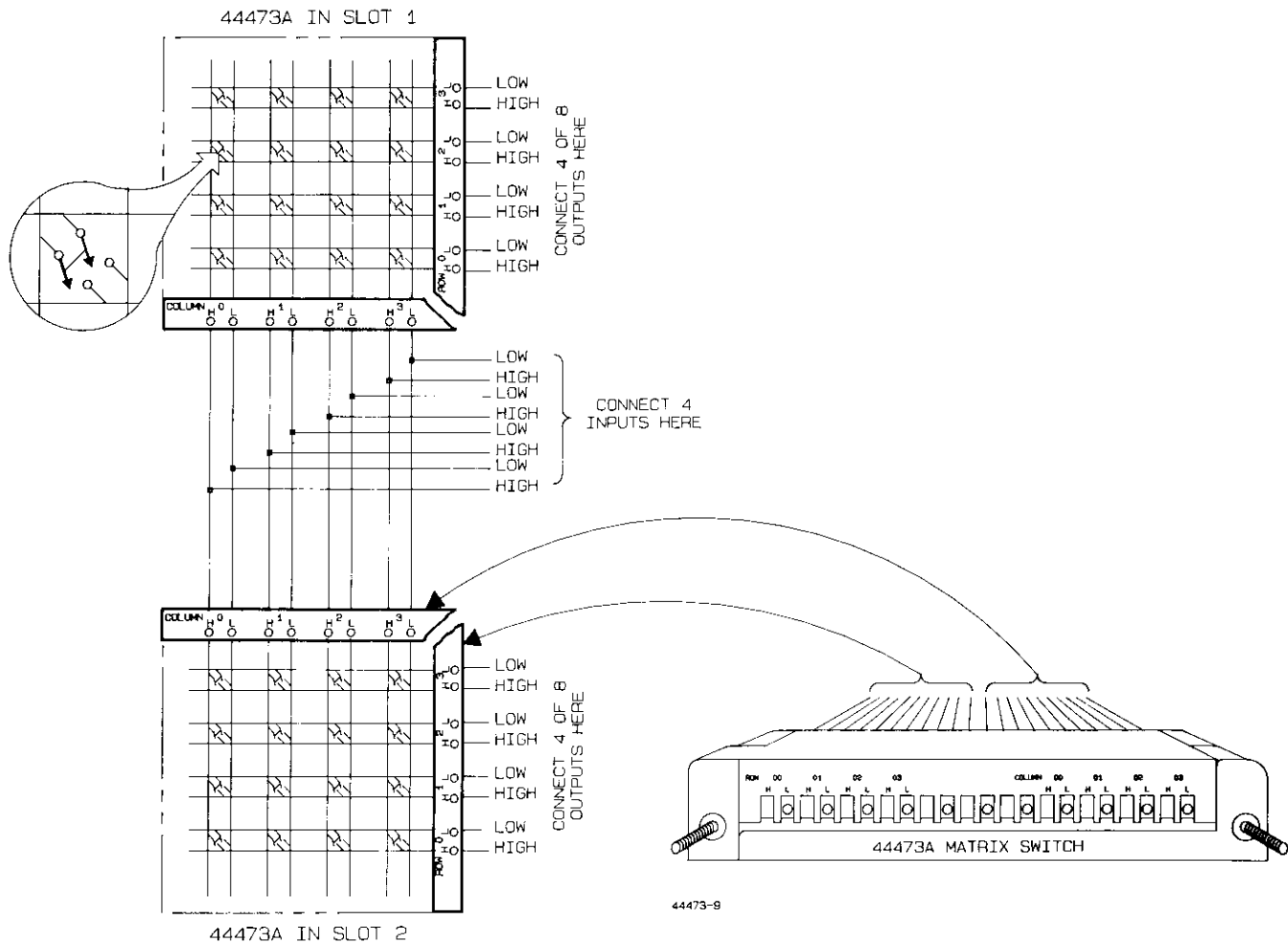
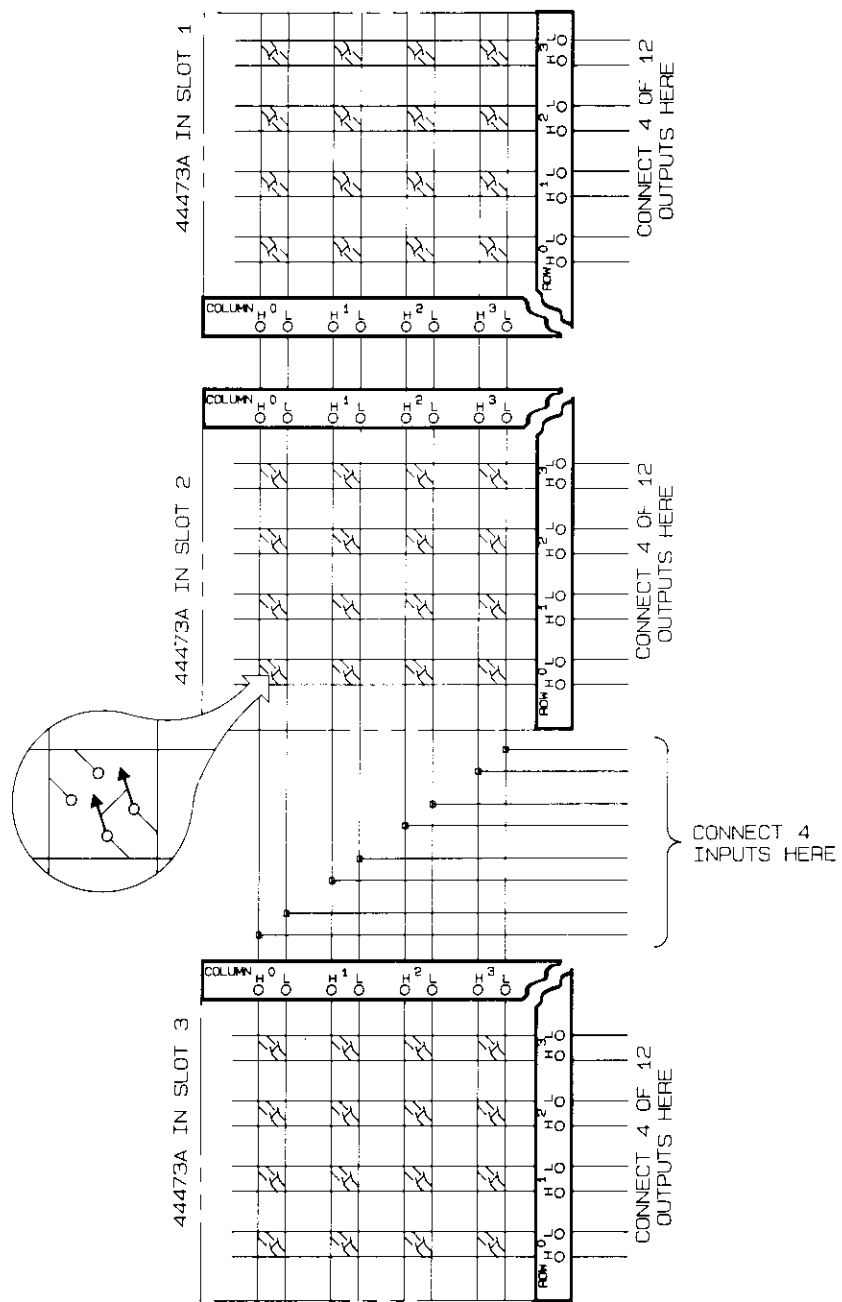
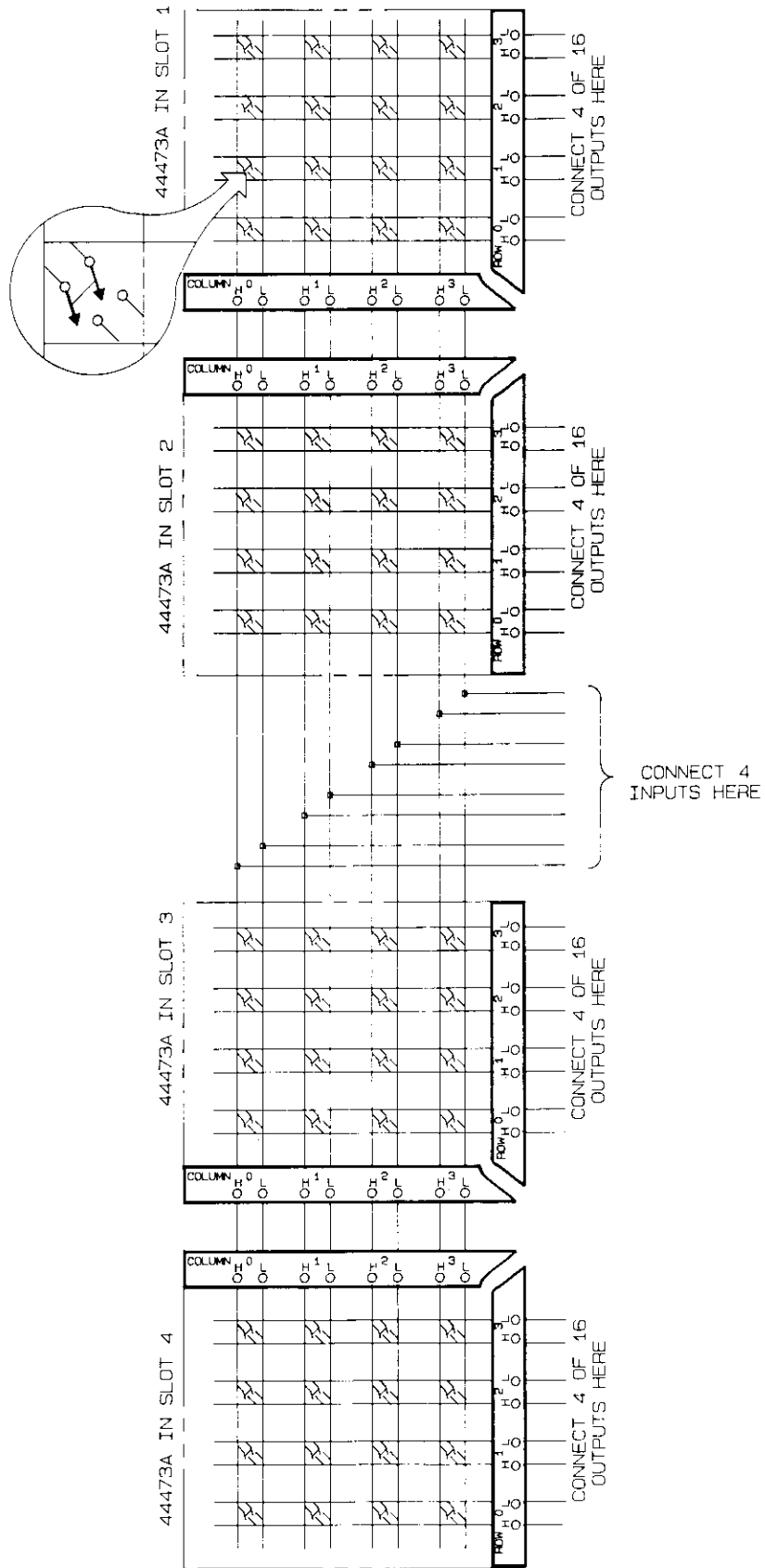

Figure 9-7. 4x8 Matrix



44473-10

Figure 9-8. 4x12 Matrix



44473-11

Figure 9-9. 4x16 Matrix

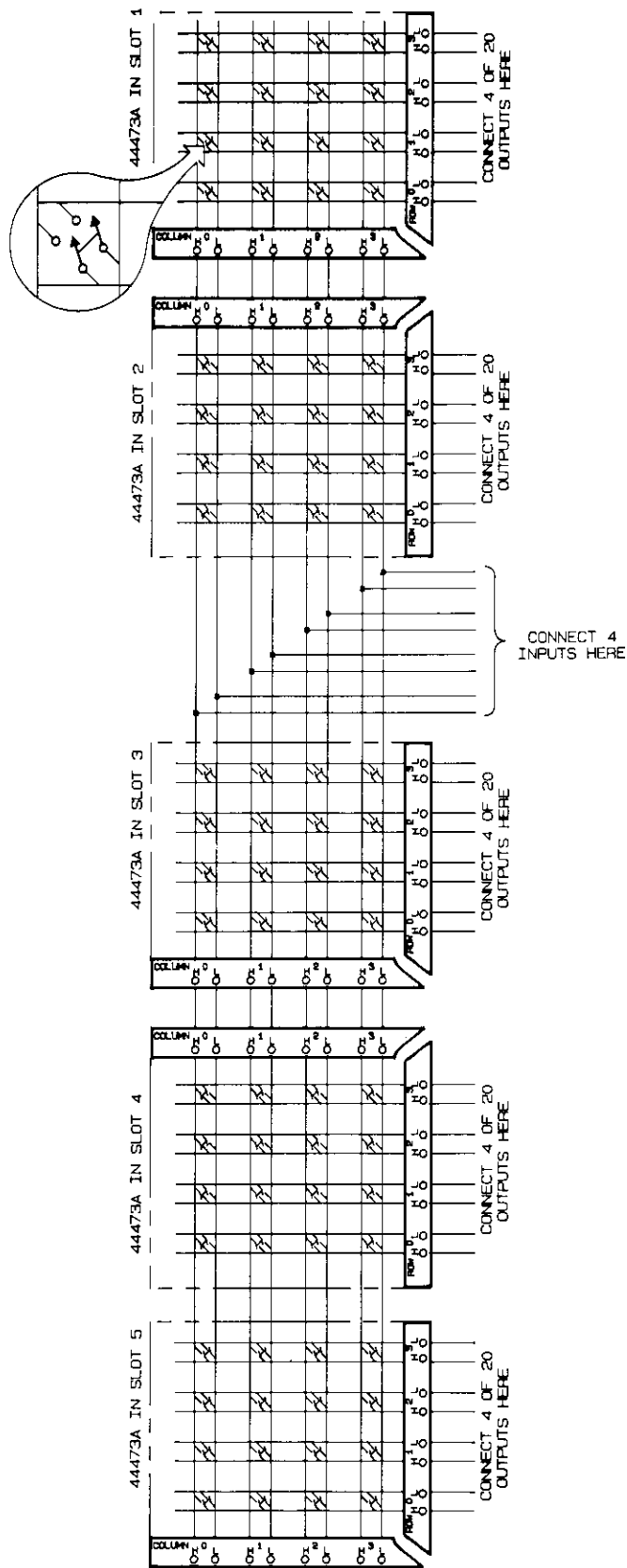

44479-12

Figure 9-10. 4x20 Matrix

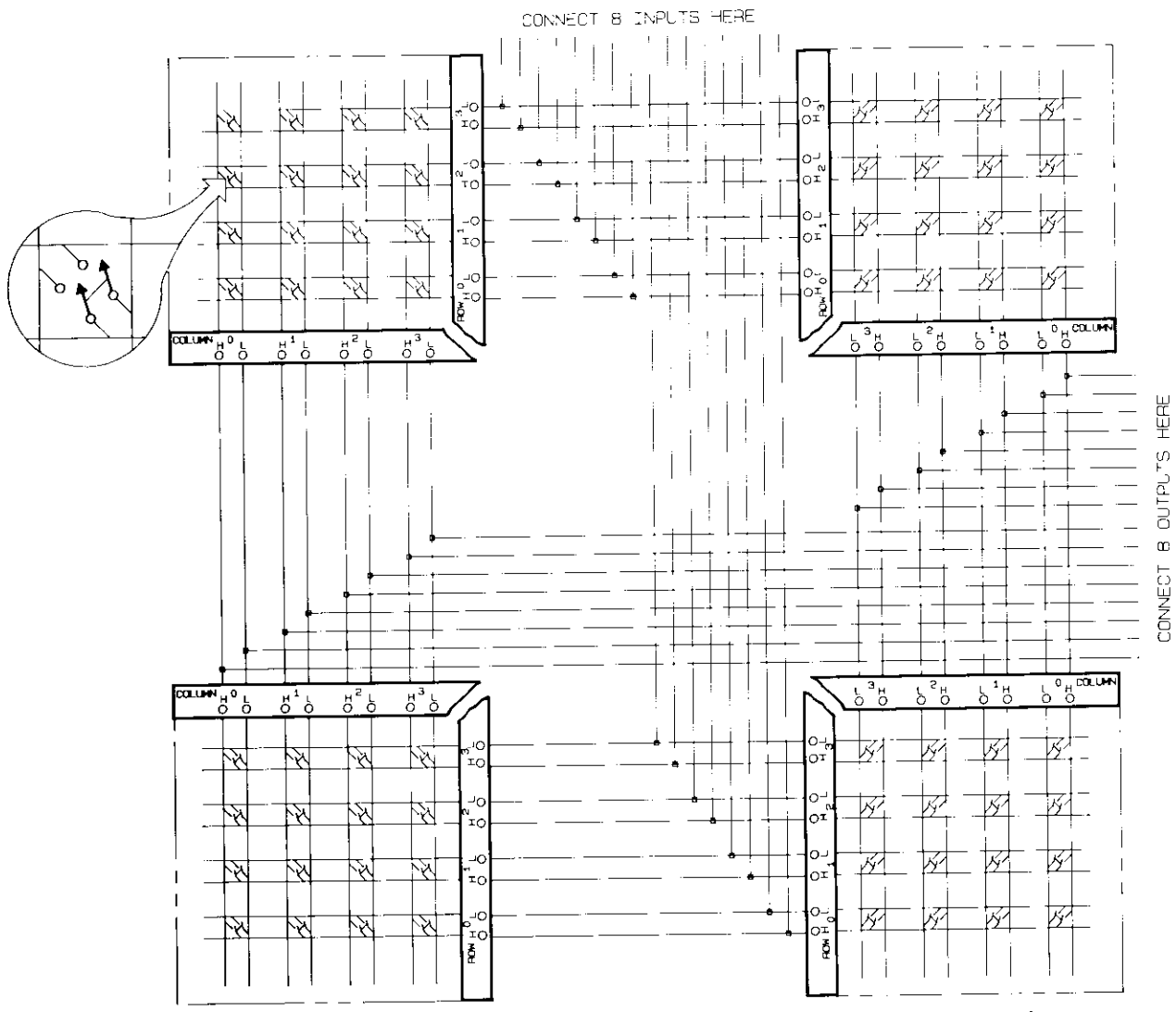

Figure 9-11. 8x8 Matrix

Example 2. Extending the Matrix to 4x40

The 44473A, when used in conjunction with four 44470A Multiplexer options can provide for a matrix of 4 inputs to 40 outputs. Actually, any one of the inputs can be connected to up to 4 outputs. Figure 9-12 shows how this can be done. Again, when connecting between option cards, keep the wire lengths as short as possible to minimize noise and signal degradation.

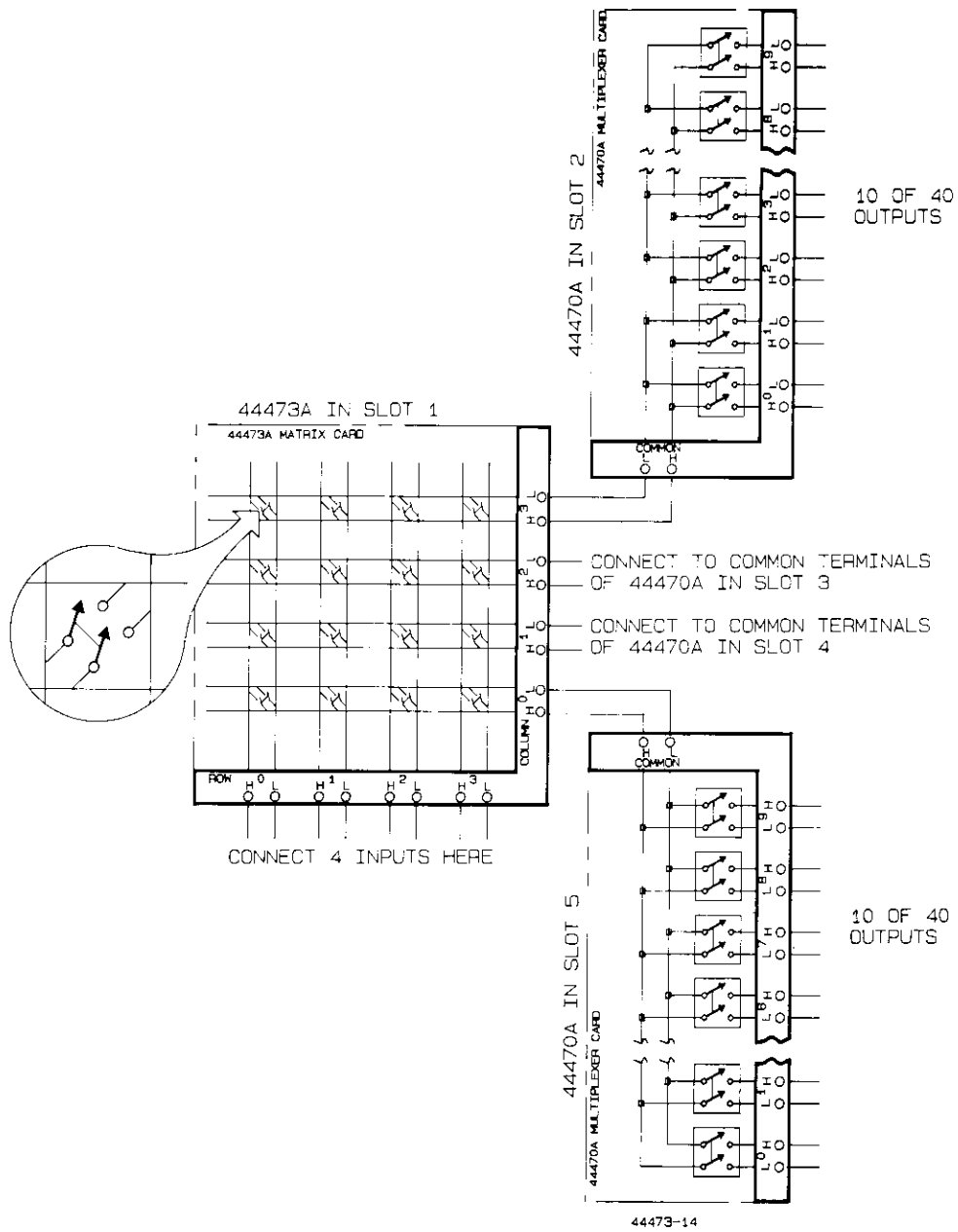

Figure 9.12. 4x40 Matrix

Table 9-2. Option 013 44473A 4 X 4 Matrix Switch Module Specifications

INPUT CHARACTERISTICS

Maximum Voltage (Terminal-terminal or terminal-chassis):
250 VDC, 250 VAC RMS, 350 VAC Peak

Maximum Current (Per channel): 2 ADC, 2 AAC RMS
(Per module): 8 ADC, 8 AAC RMS

Maximum Power (Per channel): 60 W DC, 500 VA AC
(Per module): 240 W DC, 2000 VA AC

Thermal Offset: <3 μ V differential

Closed Channel Resistance: < 3 Ω (end of relay life)

DC ISOLATION

	<(40°C,60% RH)	<(40°C,95% RH)
Open Channel, Channel-Channel*	> 10 ¹¹ Ω	> 10 ⁹ Ω
Hi-Lo*	> 10 ¹⁰ Ω	> 10 ⁸ Ω
Channel-Chassis*	> 10 ¹⁰ Ω	> 5x10 ⁸ Ω

(* with 1 channel closed)

AC ISOLATION/PERFORMANCE**

Capacitance:

Open Channel, Channel-Channel*	< 5 pF
Hi-Lo*	<40 pF
Channel-Chassis*	<70 pF

(* with 1 channel closed)

(50 Ω termination)	100 kHz	1 MHz	10 MHz
Insertion Loss (dB)	< 0.30	< 0.35	< 0.90
Crosstalk (dB)	< -76	< 56	< -36

** *With chassis of all equipment connected, and with low of input lines connected to low of output lines (either directly or via 3488A switched channel).

Chapter 10

44474A

Digital I/O Module

Introduction

Option 014 to the 3488A provides 16 bidirectional data lines (channels) plus 4 lines used for control and handshaking. All lines are TTL compatible. Several modes of operation are possible, including:

- ▶ Addressing individual lines on a bit-by-bit basis, addressing as two 8-bit ports, or addressing all 16 lines as one word.
- ▶ Positive or negative true logic.
- ▶ Several handshake modes.
- ▶ "External Increment" and "Channel Closed" signals for hardware controlled scanning.
- ▶ Several commands to write data to and read data from the option.

This chapter is designed to serve as a reference guide for using the 44474A Digital I/O Option. As such, it contains programming information, installation, and configuration information, and application examples.

The two 8-bit ports are completely independent of each other and may be used separately. For instance, one port can be used for output operations, the other for input. They can also be used together for 16-bit operations. All data and control lines are TTL compatible.

Figure 10-1 shows a simplified schematic of the 44474A option. Note that all 16 I/O lines and 4 control lines share a common LO connection.

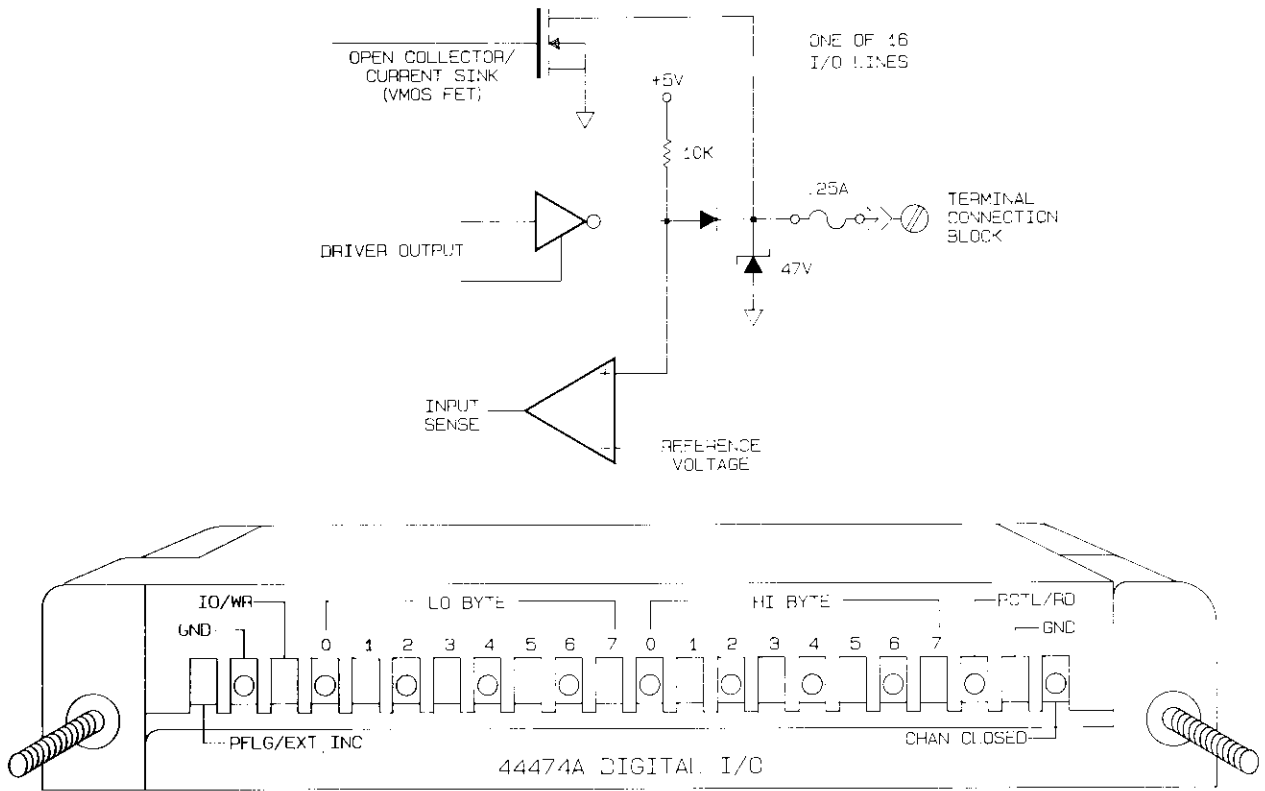

Figure 10-1. 44474A Simplified Schematic

Operation

Although several modes of operation are possible, the command discussions assume that the 44474A option is in its default Static Mode (#1, see DMODE command). This will be the case for either read or write operations. Later in this chapter you will learn to use the DMODE command and all the modes of operation.

Bit Definition

Each of the 16 I/O lines or bits, are bidirectional. This means that they can transfer information either outward (where the 3488A is controlling the bits) or inward (something external to the 3488A controls the bits and the 3488A reads them). The bits can be controlled or read either individually (bit-by-bit), as two groups of 8-bits each, or as one 16-bit word.

When used to output information, the individual bits act as switches. Because the 44474A is a digital I/O option, there are only two states for each of the bits. These two states are called Open and Closed. Figure 10-2 shows a very simple representation of one bit used as an output. The FET switch used on the 44474A can be thought of as a simple switch. Also shown in Figure 10-2 are two simple applications for the output bit.

Note that when speaking of the bit being Open, the switch is open (FET is high impedance) and point "A" is pulled up to the power supply voltage. Closed, means that the switch is closed (FET is low impedance) and point "A" is at circuit ground potential. When used in this mode, each of the output bits can sink up to 125 mA when used with up to a 30 volt supply.

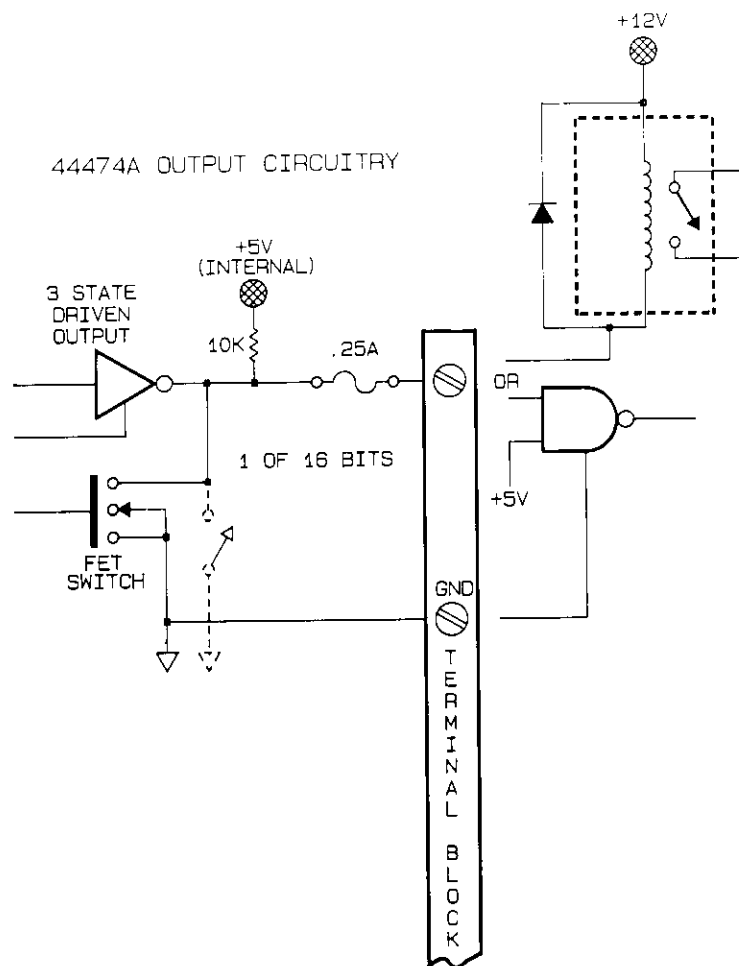

Figure 10-2. Output Bit Simplified Drawing

CAUTION

Grounding all bits and subsequently writing a 1 to all bits (bits pulled high), may cause the driver IC to exceed its power dissipation rating.

The 16 bits can also be used to input information. Figure 10-3 shows a simplified schematic of one input bit. Because the input bit has its own pull-up resistor, the bit can be used to detect switch closures to ground. Using external pull-ups, it can also be used with digital logic "high" levels of up to 30 volts.

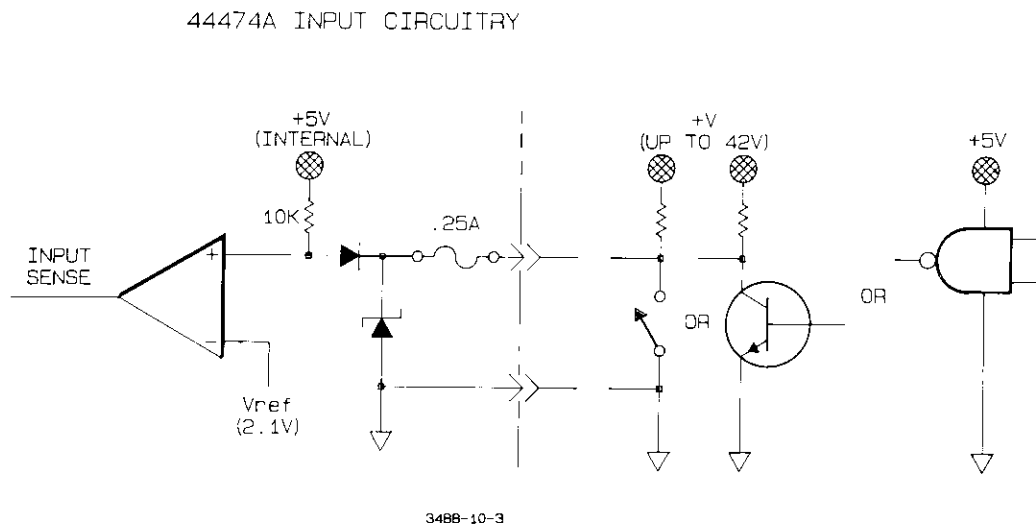

Figure 10-3. Input Bit Simplified Drawing

When used as input bits, Open means a positive voltage ($>2v$) is present and Closed means a voltage of <0.8 volts is present.

Commands

Now that we have seen a little of how the 16 bits can operate, let's learn how to control them. Most of the following commands are identical to the commands used for the other 3488A option assemblies, there are, however, some new ones. Remember, unless otherwise stated, the 44474A is assumed to be in its default Static mode (see DMODE command).

The 16 bits on the 44474A option can be addressed individually with the CLOSE, OPEN and VIEW commands. Bits, when addressed individually, are assigned a two digit number 00 through 15. The lo byte eight bits (see Figure 10-1) are assigned numbers 00 through 07. The Hi byte eight bits are assigned numbers 08 through 15.

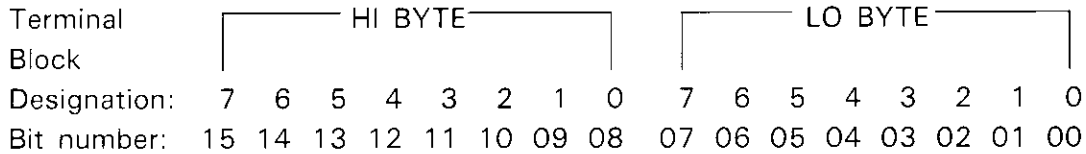

A bit address, however, is a three digit number where the first digit specifies the particular slot where the 44474A is installed. The last two digits in the bit address are the bit number. For example, bit address 503 means the 44474A is installed in slot 5, and we are addressing bit number 3 (Lo byte). Bit address 214 means slot 2, bit 14 (Hi byte).

In the following command discussions, square brackets ([]) indicate optional parameters, whereas items in < > brackets are mandatory. For further explanation of the command code mnemonics, refer to Chapters 2 and 3.

CLOSE a bit

Command Format: CLOSE <bit address>[,<bit address>,<bit address>,...]

Description

The CLOSE command is used to simply close (output mode only) one or more bits on the 44474A. Note that the CLOSE command does not open any bits (or relay channels) that were previously closed. Several bits can be closed with one CLOSE command by separating the bit addresses with a comma. If more than one bit is specified with the command, they are closed in the order listed.

The 44474A option must be in its Static Mode #1 or #2 when using CLOSE. Using the CLOSE command in any other mode will cause an error. See the DMODE command later in this chapter.

Examples

```
OUTPUT 709; "CLOSE 502,509,513"    ! Closes bits 02, 09, and 13 in slot
                                     number 5

OUTPUT 709; "CLOSE 302, 104"       ! Closes bit 02 in slot 3 and bit 04 in
                                     slot 1.
```

OPEN a Bit

Command Format: OPEN <bit address>[,<bit address>,<bit address>,...]

Description

OPEN is used to open individual bits on the 44474A option. If more than one bit is specified in the OPEN list, they are opened in the order listed. Use the CARD RESET command to open all bits on one 44474A assembly, it is easier than listing each bit.

The 44474A option must be in its Static Mode #1 or #2 when using OPEN. Using the OPEN command in any other mode will cause an error. See the DMODE command later in this chapter.

Example

OUTPUT 709; "OPEN 103,105,114" ! Opens bits 03, 05 and 14 in slot 1

VIEW a Bit

Command Format: VIEW <bit address>

Description

The VIEW command is used to look at one bit and determine whether it is open or closed. The 3488A responds with the string "OPEN 1" if the specified bit is open. If the specified bit is closed, the response is "CLOSED 0". In the 3488A display, the the bit address is displayed followed by a colon and the appropriate response.

VIEW can only be used to look at input bits. If an attempt is made to VIEW an output bit, the 8-bit port where the single bit is located will revert to an input port.

Example

OUTPUT 709; "VIEW 105" ! Views bit 05 on slot 1
ENTER 709; A\$
DISP A\$! A\$ will either be "OPEN 1" or "CLOSED 0"

or

ENTER 709; A
DISP A ! "A" will either be 1 or 0 (Open or Closed, respectively)

CARD RESET

Command Format: CRESET <slot>[<slot>,<slot>,...]

Description

CRReset is used to reset the 44474A to its default Static mode (see DMODE). Also, all bits are Opened and are operating as input bits. There is no handshaking enabled.

Example

OUTPUT 709; "CRESET 3" ! resets the 44474A in slot 3

CARD PAIR

Command Format: CPAIR <slot>,<slot>

Description

Card Pair is used to pair up two option assemblies of the same type, e.g., 44474A's. This operation will effectively assign both options to both slot numbers so that almost any command executed to one option is also executed to the other.

Commands used with the card pair function are: CLOSE, OPEN, CRESET, DWRITE, DREAD, CHAN and STEP. Of course, paired options can be used as part of a scan list. Note, only one 44474A option can be enabled for External Increment and Channel Closed. Even with Card Pairing, only the 44474A that was enabled for EI and CC will continue to be enabled.

Executing a CPAIR command cancels any previous CPAIR that involved either of the two options. It is possible to have two sets of card pairs, e.g., slot 1 paired with 3 and slot 2 paired with 5. The only requisite is that both options within one pair be the same type.

Example

OUTPUT 709; "CPAIR 1,3" ! Sets the options in slots 1 and 3 as pairs
OUTPUT 709; "CLOSE 105" ! Closes bits 105 and 305

Executing the CPAIR command without specifying slot numbers allows you to determine which, if any, slots are paired together. Four numbers are returned separated by commas. The first two numbers specify slots in the first pair, the second two numbers specify the second pair. An inactive card pair is denoted by 0,0.

Example

OUTPUT 709; "CPAIR"

ENTER 709; A\$

DISP A\$

String variable A\$ will have the four slot numbers.
Note, you may have to dimension A\$ to 30 prior to executing.

DIGITAL WRITE Command

Command Format: DWRITE <slot> <port>, <decimal data>[, <decimal data>, ...]

Description

Digital write allows you to easily close more than one bit at a time. Using the Digital Write command configures all or part of the 44474A option as an output port. The port specifier is a two digit number that indicates whether the data is to be written to the Lo 8-bit byte (port 00), the Hi 8-bit byte (port 01) or as a 16-bit word (port 02).

The decimal data is the sum of the bit values that are to be open (+5 volts or greater depending on external circuitry). All bits not specified will be closed (~0 volts). Accordingly, the decimal data must be appropriate for the port specifier. When writing to an 8-bit byte, either port 00 or port 01, the decimal value must be between 0 and 255. Refer to Bit Value Table 1.

	Hi Byte Port 01								Lo Byte Port 00							
Bit number:	15	14	13	12	11	10	09	08	07	06	05	04	03	02	01	00
Bit Value:	128	64	32	16	8	4	2	1	128	64	32	16	8	4	2	1

Bit Value Table 1.

Example

How would you close only bits 2 and 5 (values 4 and 32, respective) in slot 1 (port 00). The bit pattern could be represented as:

Bit Number:	7	6	5	4	3	2	1	0
Bit state:	1	1	0	1	1	0	1	1

Where a "1" indicates the bit is open, and a "0" means the bit is closed. Summing the values for the open bits yields: $128 + 64 + 16 + 8 + 2 + 1 = 219$. Therefore, execute the command:

OUTPUT 709; "DWRITE 100, 219"

To close bits 10, 12 and 14 (values 4, 16, and 64, respective) in slot 5 (port 01), picture the bit pattern as:

Bit number:	15	14	13	12	11	10	9	8
Bit state:	1	0	1	0	1	0	1	1

The sum of the values for the open bits is 171. Therefore, execute:

OUTPUT 709; "DWRITE 501, 171"

When writing to port 02, the 16 bit word, the decimal value can have a range of -32768 to $+32767$. Any time the summed value of the open bits would exceed $+32767$, the 2's complement form must be used and expressed as a negative number. Refer to Bit Value Table 2 for the bit values in the 16 bit word mode.

Bit Number:	15	14	13	12	11	10	9	8	7	6	5	4	3	2	1
Value:	32768	16384	8192	4096	2048	1024	512	256	128	64	32	16	8	4	2

Bit Value Table 2.

Example

To close only bits 12, 9, 5 and 2 in slot 3 (port 02), the bit pattern could be represented as:

Bit Number:	15	14	13	12	11	10	9	8	7	6	5	4	3	2	1	0
Desired State:	1	1	1	0	1	1	0	1	1	1	0	1	1	0	1	1

Normally, the summed bit values for the open bits would be 60891. This exceeds the limit of 32767 and therefore must be converted to 2's complement form. This conversion is a simple two step process.

First, complement, i.e, invert, the bit states:

Bit Number:	15	14	13	12	11	10	9	8	7	6	5	4	3	2	1	0
Desired State:	1	1	1	0	1	1	0	1	1	1	0	1	1	0	1	1
Inverted State:	0	0	0	1	0	0	1	0	0	0	1	0	0	1	0	0

Now, add 1 to the inverted state:

$$\begin{array}{r} 0001001000100100 \\ + 1 \\ \hline 0001001000100101 \end{array}$$

This final result is the 2's complement form of the bit pattern we desire. Add together the values of the bits designated as 1's and execute that as a negative number:

OUTPUT 709; "DWRITE 502, -4645"

DIGITAL READ

Command Format: DREAD <slot><port>[,<number of times to read data>]

Description

The DREAD command permits reading the input bits on the 44474A option. Like the DWRITE command, the port specifiers are 00 for the Lo 8-bit byte, 01 for the Hi 8-bit byte and 02 for reading the entire 16-bit word.

This command also permits multiple readings from the option with one command. If no "number of times to read data" is specified, the data will be read only once. Each reading is sent as six characters. In the case of multiple readings, the information is sent as a block with the readings separated by commas. If multiple reads are desired, the 3488A must be in the OLAP1 mode.

If the 44474A is in its Static Mode #1, the DREAD command will read the input data. In order to verify an output port, the 44474A must be in its Static Mode #2. This will enable reading the outputs.

Example

```
10 DIM A$(700)
20 OUTPUT 709; "OLAP 1"
30 OUTPUT 709; "DREAD 501, 100"      ! Take 100 readings
40 ENTER 709; A$                      ! Enter all 100 readings
50 DISP A$                            ! Display readings
60 END
```

Note, when data items are read over the HP-IB interface to the computer, the 3488A will remain busy until all items have been read by the computer.

CARD MONITOR Mode

Command Format: CMON <slot>

Description

The card monitor display for the 44474A Digital I/O option is similar to the photograph below. The H and L represent the High and Low 8-bit bytes, respectively. A trailing decimal point for either byte indicates that the last operation on that byte configured it as an output byte (e.g., DWRITE or CLOSE). If the decimal point does not appear, the byte is configured as an input byte.

When initially entering the card monitor mode, the display will indicate a decimal value. This decimal value is equal to the sum of the bit values that are in a high state. For an output byte, this means the the bits that are open. Refer to the following chart for a description of bit values.

	Hi Byte								Lo Byte							
Bit number:	15	14	13	12	11	10	09	08	07	06	05	04	03	02	01	00
Bit Value:	128	64	32	16	8	4	2	1	128	64	32	16	8	4	2	1

Pressing either of the front panel arrow keys causes the display to switch to a hexadecimal (base 16) format for the display.

Example

If the last comand sent to the 44474A option put it into the 16 bit word mode (e.g., DWRITE to port 02), the monitor would also be displayed as a 16-bit word. A positive number indicates the sum of the bit values for the open bits. A negative number indicates the display is in 2's complement format.

To decode 2's complement format, first determine the binary representation for the display. Next, invert all bits and add 1. For example, if the display shows a -1234, the binary representation would be:

```

Bit Number:      15 14 13 12 11 10 9 8 7 6 5 4 3 2 1 0
Bit State:       0  0  0  0  0  1 0 0 1 1 0 1 0 0 1 0
  
```

Refer to the section on DWRITE for information on bit values.

Inverting this result gives a bit pattern of:

```

Bit Number:      15 14 13 12 11 10 9 8 7 6 5 4 3 2 1 0
True Bit State:  1  1  1  1  1  0 1 1 0 0 1 0 1 1 0 1
  
```

Now, add 1 to this and the result is:

```

Bit Number:      15 14 13 12 11 10 9 8 7 6 5 4 3 2 1 0
Bit State:       1  1  1  1  1  0 1 1 0 0 1 0 1 1 1 0
  
```

DIGITAL MODE Command

Command Format: DMODE <slot>[, <mode>][, <polarity>][, <EI>]

Description

This command is used to establish the handshake mode as well as polarity of the 16 I/O bits and control lines for the 44474A Digital I/O option. In addition, it is also used to enable/disable the External Increment and Channel Closed functions.

Mode Definition

Various handshaking modes are determined by the Mode specifier. This specifier is a number from 1 to 5 according to the following table:

Mode	Specifier Number
Static	1
Static, read outputs	2
R/W and Strobe	3
Rd & WR Strobe	4
Handshake (no EI or CC)	5

Note

Modes 3, 4 and 5 can only be used with port specifiers 00 and 02. Port 01 can be either Static Mode 1 or 2.

Static Mode #1

Static mode #1 is the default mode of the 44474A Digital I/O option. In this mode, data is transferred statically, that is, no read or write strobe pulses or handshaking. The I/O direction line is active though to indicate direction of transfer. This is shown in the following timing diagrams.

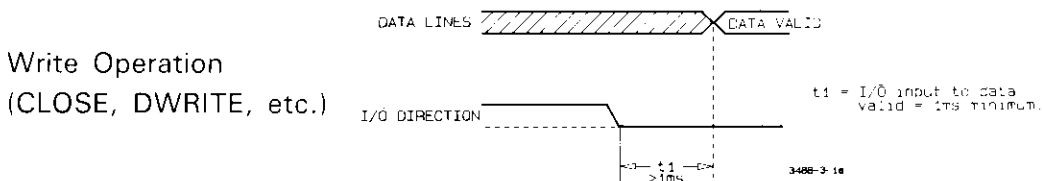

This diagram shows that approximately 1mS after the 3488A is instructed to write data to the 16 data I/O lines (I/O direction line goes to a low state), the 44474A takes control of the data lines.

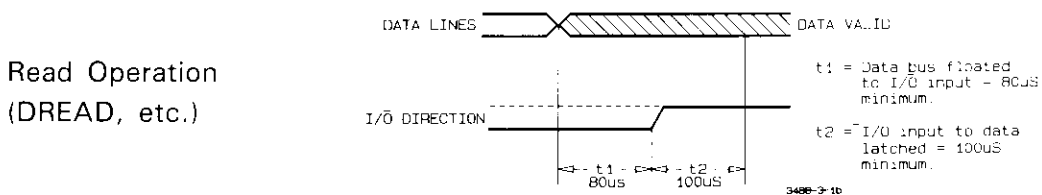

This diagram shows that $100\mu\text{S}$ after the 3488A is instructed to read the 16 Data I/O lines, it releases control of the lines and the I/O direction line goes to a high state. $120\mu\text{S}$ later, the data is actually read (latched).

Static Mode #2

Static Mode #2 acts just like Mode 1 except that the output lines are not disabled when the option is read (DREAD, etc.). This means that if a port is written to and then read from, the data read will be that which was just written to it. It is possible, however, that external devices might load the lines and cause a false read.

Timing for the I/O direction line is as shown in Mode #1, except for read. During a read operation, there is no change in the I/O direction line.

R/W and Strobe Mode #3

In this mode, the I/O direction line is still used to indicate direction of transfer (input or output) but the PCTL (Peripheral control) line is used to strobe the data.

During a Write operation, where the 3488A writes the data to some external device, the strobe pulse signifies that the data on the 16 Data I/O lines is valid. This is shown in the following timing diagram.

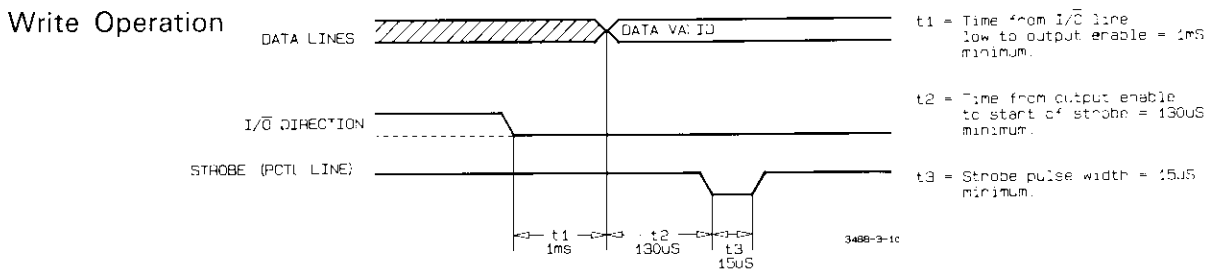

A Strobe pulse is used by the 3488A to signify that the data on the data lines is valid. Therefore, during a Write operation, the device receiving the data is triggered by the Strobe pulse.

The strobe pulse is used during a Read operation to signify that the 3488A has completed the read operation. This is shown in the following diagram.

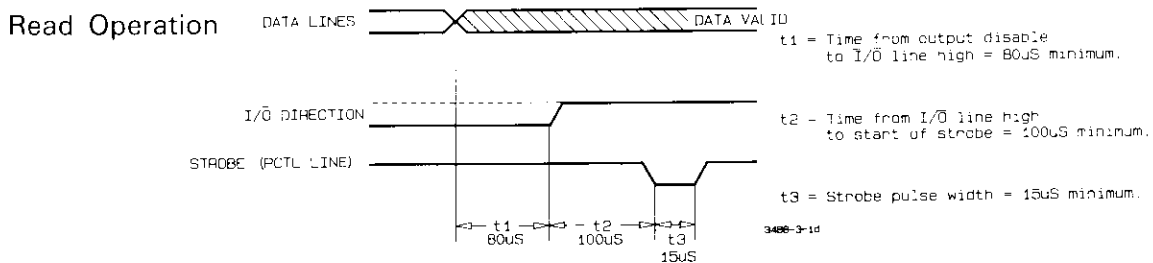

When used during a Read operation, the Strobe pulse signifies that the 3488A has latched (read) the data from the data lines.

Read and Write Strobe Mode #4

The Read and Write Strobe Mode uses the I/O direction line as a strobe pulse to indicate writing operations. The PCTL line is used to indicate Read operations. It is thus similar to the R/W and Strobe Mode #3 except separate control lines are used for the strobe pulses and there is no I/O direction line.

Write Operation

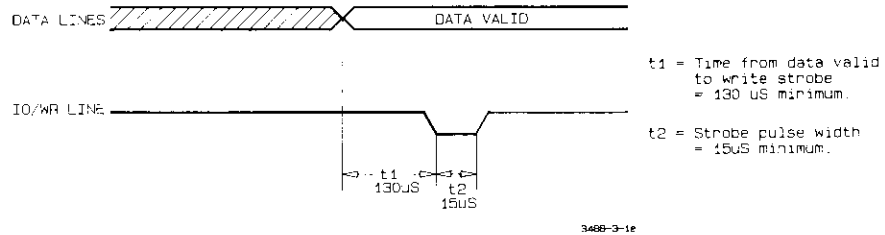

The IO/WR line is used to indicate that the data is valid on the data bus lines. IO/WR is used to trigger the receiving device.

Read Operation

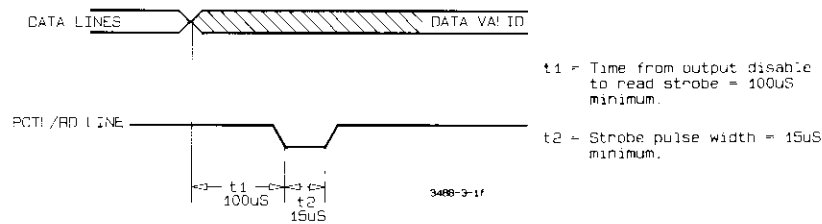

As in Mode #3, the PCTL/RD line is used to indicate to the sending device that the 3488A has latched (read) the data.

Handshake Mode #5

This fifth mode provides a complete two wire handshake with a data direction line. During Write operations, the PCTL line indicates that output data is valid; during Read operations, it indicates that the 44474A is "ready for data." The PFLG line is used by the peripheral device to indicate "ready for data" during write operations or "data valid" for read operations.

Remember, Write operations are the 3488A/44474A controlling the data on the 16 Data I/O lines. Two commands used during Write operations are DWRITE and CLOSE. Read operations are where external devices control the 16 data lines and the 3488A/44474A simply reads the data and controls the PCTL/RD line.

Write Operations

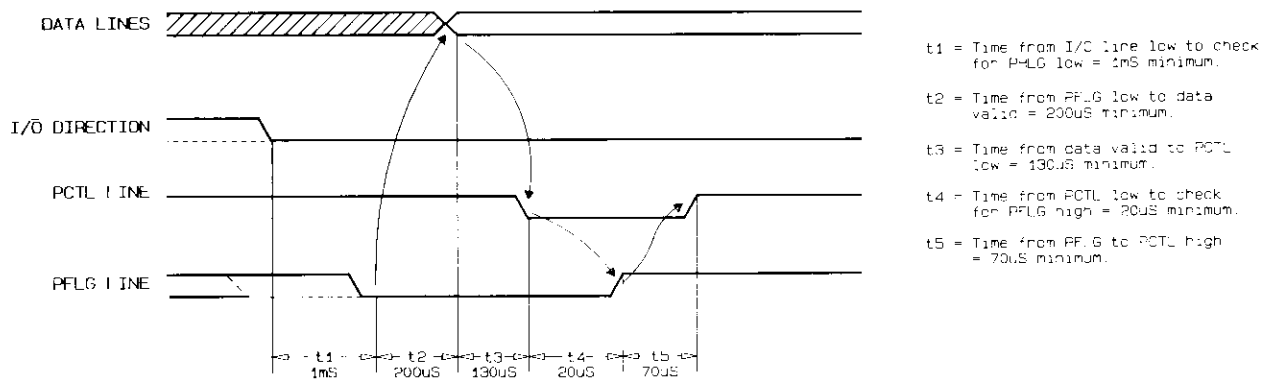

The complete handshaking sequence for Mode #5 is as follows: The 3488A checks to see if the receiving device has set the PFLG line low, this indicates the receiving device is ready to accept data. When PFLG is low, the 3488A sets the data on the data bus and sets PCTL low. The 3488A then waits for the receiving device to set PFLG high, indicating that it has latched the data. To complete the handshake, the 3488A sets PCTL high.

Read Operations

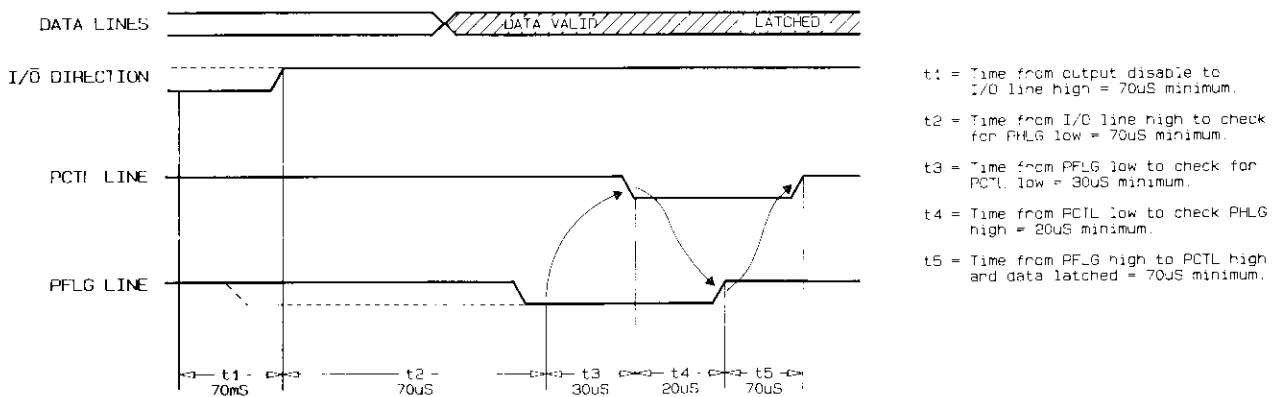

As with the Write operation, the 3488A begins by testing PFLG for a low state, indicating that the data is valid. When PFLG is low, the 3488A sets PCTL low and waits for PFLG to go high. The 3488A will set PCTL high to indicate that it has completed the data read operation. Data on the data bus must remain valid until after the 3488A sets PCTL high.

Polarity Definition

The Polarity specifier for the DMODE command is used to set the polarity of both the 16 data lines and the handshake/control lines. When the polarity of the control lines is changed by this command, the 44474A will immediately change the states of the affected lines. For the data lines, the current state is not immediately changed, but the new polarity will be used in subsequent operations.

The polarity specifier in the DMODE command is a decimal weighted defined in Table 10-1.

Table 10-1. Polarity Specifier

Definition	Value
Default, data lines high true (open), PCTL and PFLG low means ready, I/O Direction line high for ready.	0 = Default
Lo 8-bit byte	1 = Low true
Hi 8-bit byte	2 = Low true
PCTL Polarity	4 Low means ready, High means busy
PFLG Polarity	8 = Low means ready, High means busy
I/O Direction line polarity	16 Low means input, High means output

To illustrate the use of the polarity specifier for the Hi and Lo bytes, consider that normally, that is the default mode, the 16 data lines are high (+5 volts) for open and lo (0 volts) for closed. This is true whether a write or read operation is performed. By inverting the polarity for either or both bytes, high (+5 volts) then becomes closed and lo (0 volts) becomes open.

Changing the polarity of the PCTL, PFLG or I/O Direction line will affect the handshaking control. Refer to the handshaking timing diagrams in the Mode definition. If you change the polarity of either the PCTL, PFLG, or I/O Direction lines, invert the drawing for that line. For example, the I/O direction line in Static Modes # 1 and 2 for a Write operation looks like:

Write Operation

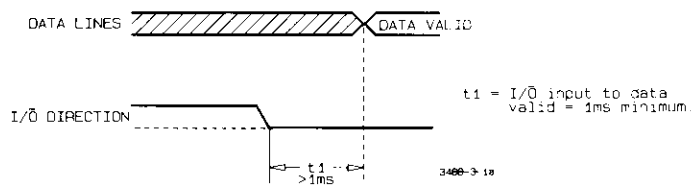

Here, a low on the I/O Direction line indicates a Write or output operation. After executing the command "DMODE 5,1,16,0" (polarity specifier of 16 changes the polarity of the I/O Direction Line), the diagram would look like:

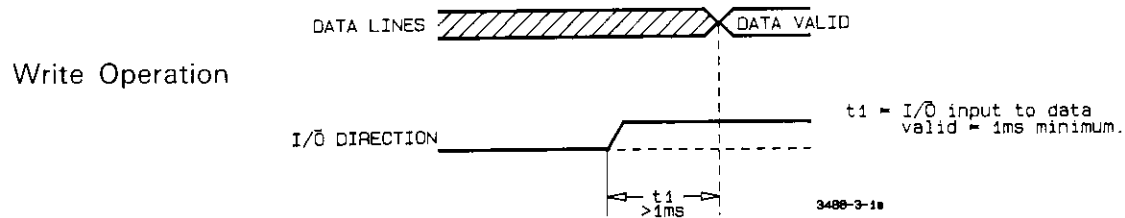

Now, the direction line effectively becomes inverted and a high means an output operation.

External Increment Definition

External Increment (EI) provides a method of sequencing through a scan list without system computer intervention. EI is enabled by specifying 1 in the EI specifier for DMODE and disabled by specifying 0.

Typically, EI is connected to the Voltmeter Complete* output on a system voltmeter. The Channel Closed line (CC) can be connected to the External Trigger input on the voltmeter. The scan is started by executing either STEP or CHAN. As soon as the channel closes, the 44474A outputs a CC pulse, triggering the voltmeter. As soon as the voltmeter completes its measurement, it outputs the Voltmeter complete pulse which increments the scan list. When the next channel closes, CC is once again sent and the process continues to sequence through the scan list.

The number 0 may be inserted in the scan list to act as a stop channel. When it is encountered, the 3488A opens the last channel closed but will not close a new one and CC is not sent.

Only one 44474A option can be configured for EI and CC use in scanning. If one option is enabled and another is subsequently enabled, the first will become disabled.

Figure 10-4 shows the timing relationship for the scan sequence when using EI and CC. If the 3488A receives either an EI or the HP-IB Trigger command while the instrument is busy with another command, the Step command will be executed as soon as the command in progress is completed. If EI is received while the 3488A is busy executing a previous EI, a "trigger too fast" error will be generated.

* Voltmeter Complete is a feature on most Hewlett-Packard digital voltmeters to signal the completion of a measurement by means of a TTL compatible pulse.

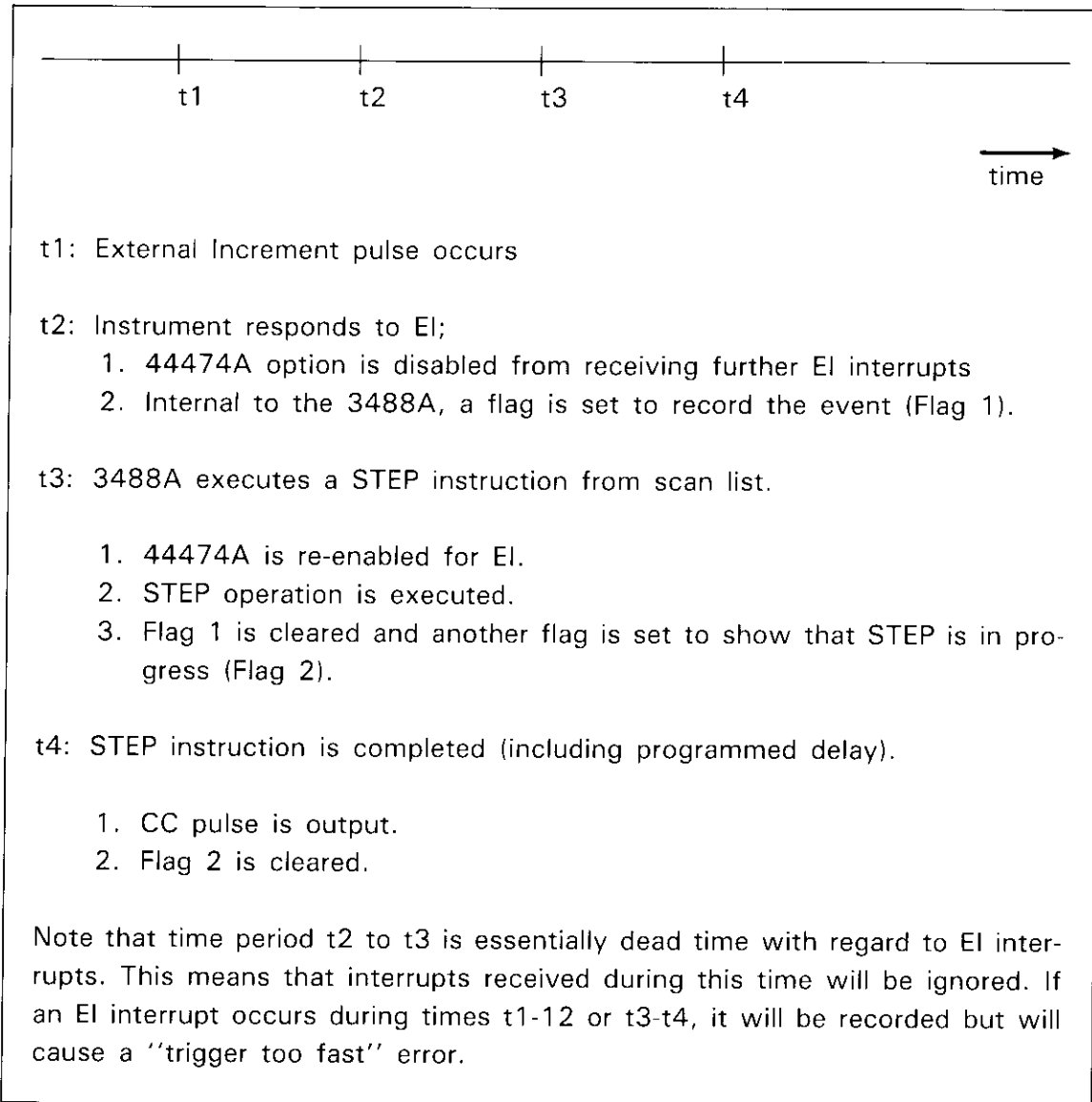

Figure 10-4. Scan Timing

SCAN LIST

Command Format: SLIST [<ch. address>(, or -)<ch.address>...<ch. address>]

Description

Scan List allows you to specify a sequence of channels to be scanned. The sequence is specified as a list of up to 85 channel addresses (relay or digital I/O bits) and/or stored setups separated by commas. Contiguous channel addresses may be specified by entering the first channel address and the last channel address separated by a hyphen. STEP is used to sequence through the list.

Example

```
10 OUTPUT 709; "SLIST 104,205,300-309,410,0"  
20 FOR I = 1 TO 14  
30 OUTPUT 709; "STEP"  
40 NEXT I
```

In this example, the scan would start by closing channel 104. After the next STEP command channel 104 would open and channel 205 closes. The next STEP causes 205 to open and 300 to close. Next, 300 opens and 301 closes. This continues until the number 0 is reached which opens channel 410 but closes not other channels.

Notes:

1. Channels may be scanned in any sequence, i.e., 309-300.
2. Stepping beyond the last channel specified in the scan list causes a wraparound to the first channel in the list unless the number 0 is used as a stop channel.
3. The commands OPEN, CLOSE, CRESET, or RECALL will have no effect on the scan list even though the state of individual channels may change.
4. Stored setups may be recalled as part of the scan list simply by specifying the register number. For example, SLIST 104-106,25,200,502. Here, register number 25 is recalled.
5. Channels that are closed by recalling a stored setup are not opened by subsequent STEP commands. Individual channels will be opened if and when they are encountered later in the scan list.

STEPping Through the Scan List

Command Format: STEP

Description

STEP is used to initiate and sequence through a scan list. If STEP is executed and no scan list is in effect, an error will be generated.

The 3488A uses an internal pointer to keep track of which channel in the list is currently closed. When STEP is executed, that channel opens and the next item in the list is checked. If the next item in the list is either a relay channel or digital I/O bit, that channel is closed. If the next item in the list is a stored setup, that setup is recalled. Channels that are closed by recalling a stored setup are not opened by the execution of STEP.

Example

```
10 OUTPUT 709; "SLIST 100-109,25,200,301,303"  
20 FOR I= 1 TO 14  
30 OUTPUT 709; "STEP"  
40 NEXT I
```

CHANnel Command

Command Format: CHAN [<ch. address>]

Description

CHAN is used to open the last channel closed by either STEP or CHAN and close the the specified channel. If no channel is specified with CHAN, the 3488A will respond with the last channel closed by either STEP or CHAN. If no channel has been closed since the last reset, CHAN returns the number 0.

If a scan list is in effect when CHAN is executed, the 3488A will search through the list and position the scan list pointer to the channel specified by CHAN. If CHAN specifies a channel that is not in the scan list, and then STEP is subsequently executed, the 3488A will open the channel closed by CHAN and proceed to the beginning of the scan list.

Examples

```
OUTPUT 709; "CHAN 202"      ! closes channel 202
```

```
OUTPUT 709; "CHAN"
```

```
ENTER 709; A
```

```
DISP A
```

! Variable "A" contains the last channel closed by CHAN, i.e., 202.

DELAY time

Command Format: DELAY [<time in mS>]

Description

The DELAY command is used to insert a time delay between the time that a channel is closed and the next command or Channel Closed pulse is executed. The Delay time is specified from 0 to 32,767 mS (32.767 seconds) in 1 mS intervals. The delay time does not become effective until either CHAN or STEP is executed.

If any command is sent to the 3488A during the delay time, the command will be executed as soon as the delay is complete. If there is not a time value sent with the DELAY command, the 3488A will respond with the current value of delay time.

Remember that the Channel Closed pulse will be sent after the delay time is complete from the 44474A option that has External Increment enabled.

Examples

```
OUTPUT 709; "DELAY 2000; CHAN 101"
```

```
OUTPUT 709; "DELAY"
```

```
ENTER 709;A
```

```
DISP A
```

```
! Display the current delay time: 2000 mS
```

DIGITAL BINARY WRITE

Command Format: DBW <slot> <port> ,#I<block data>

Description

When the DBW command is received, the 3488A will interpret the data that follows as a block of binary data. This data is to be output according to the mode set up for the option by the DMODE command. In the 16 bit mode (port 02), the incoming data is interpreted as being the high or most significant byte first.

Port definition is: port 00 is lo 8-bit byte, port 01 is high 8-bit byte, and port 02 is 16-bit word.

IMPORTANT. Transfer is completed by the HP-IB EOI line going true concurrently with the last byte of data. The following program shows how to implement EOI on the -hp- 80 series of computers.

Example

```

10 CONTROL 7,16;128
20 DIM A$(30)
30 IOBUFFER A$
40 A$="CMON 5;DBW 502, #IAS"
50 TRANSFER A$ TO 709

```

Line 10 configures the Series 80 computer HP-IB interface to set EOI true concurrent with the last character sent. Line 40 contains the actual commands that will be sent to the 3488A (line 50). The DBW 502,#IAS will send the ASCII characters A and S to the 44474A option. The final bit configuration will be:

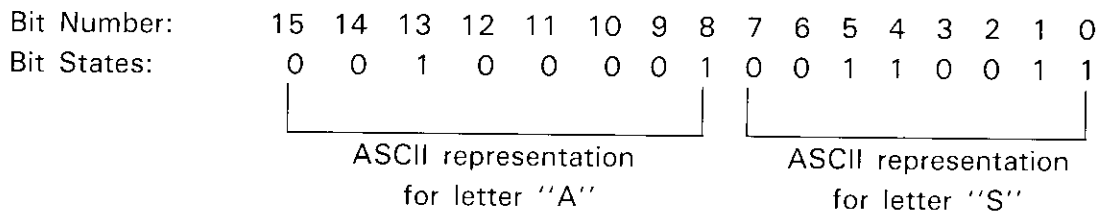

DIGITAL BINARY READ

Command Format: DBR <slot><port>,[<number of times to read>]

Description

In the binary read mode data items are read and sent according to the format set by the slot/port specifier and DMODE command. If 16-bit mode (port 02) is specified, data will be sent with the most significant (high) byte first. The data transfer is terminated by the 3488A setting EOI true on the HP-IB interface. This is done concurrently with the last byte of data output. The maximum number of data items that can be specified with the DBW command is 32,767.

Note. If more than one reading is requested, the 3488A must be in the OLAP1 mode. This command must be done on a separate program line because it does not become active in the 3488A until the first Bus communication after OLAP has been asserted.

Example

The following program shows how to configure a Series 80 computer for responding to EOI true concurrent with the last character sent.

```
10 DIM A$(30)
20 A$ = "DBR 502,1"
30 IOBUFFER A$
40 TRANSFER A$ TO 709 INTR
50 ENTER 709 USING "%,K"; B$
60 DISP B$
```

Line 50 uses the image specifiers % and K to respond to EOI true concurrent with the last character sent.

HP-IB Interface Commands

Only two interface commands affect the state of the 44474A channels: TRIGGER (Group Execute Trigger) and CLEAR (Device Clear or Selected Device Clear). TRIGGER performs the same function as the 3488A STEP command. In other words, the two commands:

TRIGGER 7 (or TRIGGER 709)

and

OUTPUT 709; "STEP"

perform the same function as far as the 44474A assembly is concerned.

CLEAR, whether a Device Clear or Selected Device Clear, simply resets the 3488A and hence all relays will go to their open state.

44474A Assembly Installation

This portion of the chapter is written specifically for the service trained technician. It provides the necessary information for a person trained in electronic circuitry to configure and install the option assembly. Carefully read through this section and adhere to all cautions and warnings.

WARNING

Only qualified service trained personnel should remove, configure, or install the 3488A option assemblies. Disconnect the 3488A power cord from the back of the instrument prior to installing the option assemblies.

When you initially received your 3488A, the option assemblies were not installed in the mainframe. Each option assembly was packaged separately along with a terminal block edge connector and a two piece strain relief housing. In addition, two labels were provided for option identification.

CAUTION

Use clean handling and anti-static procedures when removing, configuring and installing the option assemblies. The circuit boards must be kept clean to ensure compliance with impedance specifications. The option assemblies as well as the 3488A mainframe contains CMOS devices which are susceptible to static discharges.

A few simple steps are required to install the 44474A assembly. Carefully observe the orientation of the assembly and terminal block as you install them.

1. Pre-installation
 - a. Remove the ac power cord from the 3488A before installing any option assembly.
 - b. Position the 3488A with the rear panel towards you.
 - c. Select a slot. Refer to Figure 10-5, the 3488A has five slots for installing option assemblies. The 44474A can be used in any of the five slots.

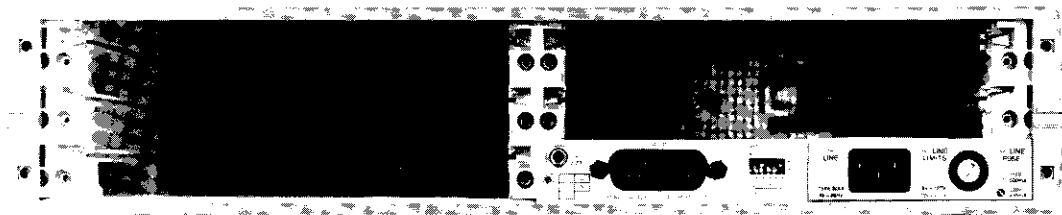

Figure 10-5. Rear Panel View of the 3488A

2. Option assembly installation

- a. Hold the option assembly, component side down, by the metal shields. Insert the circuit card into the slot guides and slide toward the front of the instrument. Push firmly until the assembly 'snaps' into place. Fold the plastic levers toward the assembly. These levers lock the option into the mainframe.

NOTE

To remove the option assembly, simply unfold the plastic tab levers. This will release the locking mechanism and pull the option out of the mainframe connector.

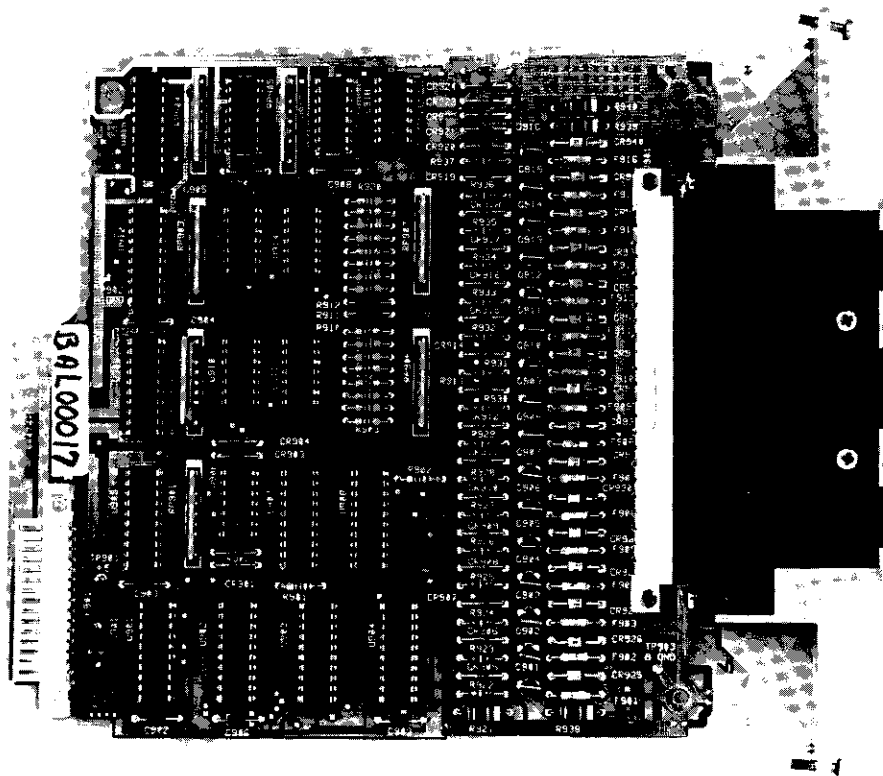

Figure 10-6. Option Card

3. Terminal Block Wiring

a. Wire the Terminal Block Edge Connector. Figure 10-7 shows the channel connection sequence for the 44474A Terminal Block Edge Connector. This terminal block is keyed to fit only the 44474A assembly. Extra terminal blocks are available under the -hp- part number 44484A.



Figure 10-7. Terminal Block

4. Strain Relief

a. Secure the terminal block to the strain relief housing with the captive screws on the terminal block. Make certain that the screws used to tighten the connector wires to the terminal block are accessible through the strain relief housing.

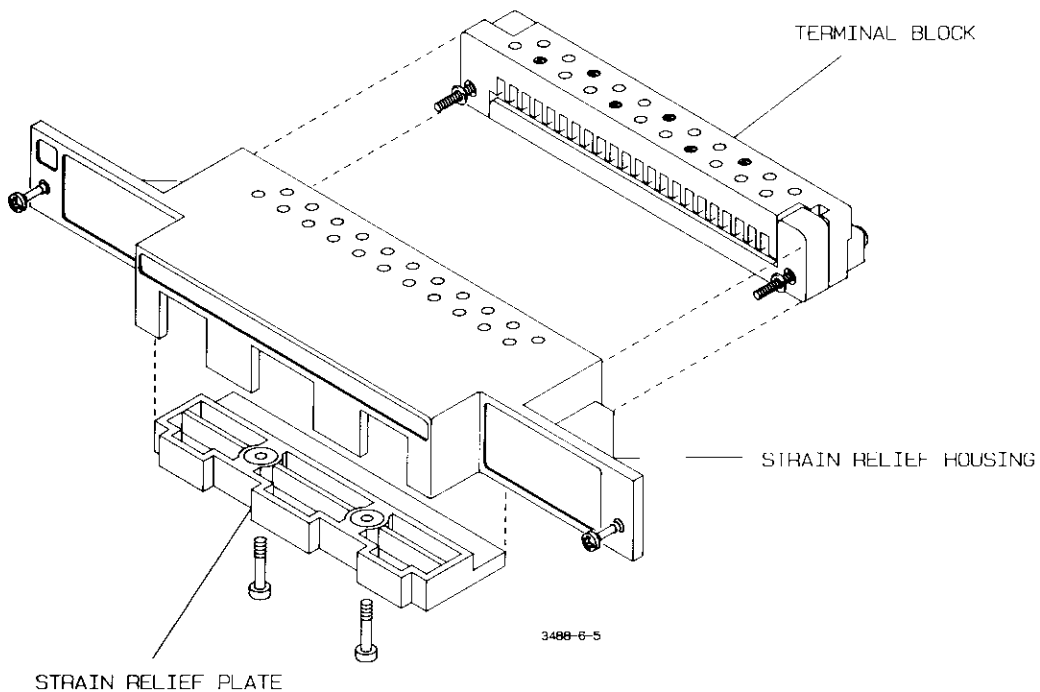

Figure 10-8. Strain Relief Housing

b. Route the wires evenly through the three strain relief cutouts. This will ensure a uniform amount of strain relief. If only a few wires are used, they should go through the middle cutout.

c. To protect wires smaller than 22AWG it is recommended that these wires be bundled together starting no more than 4" from the back of the 3488A. Failure to do so may cause wires to break at the strain relief. To illustrate the need for this, a 26AWG wire can survive about 7 to 8 pounds of tension before breaking. A bundle of 10, however, could survive up to 70 pounds of tension.



Figure 10-9. Cable Routing

d. Secure the strain relief plate to the strain relief housing (ribbed side down). Do not over tighten the screws.

e. Push the terminal block with strain relief housing onto the option assembly connector. Tighten the two screws on either end of the housing.

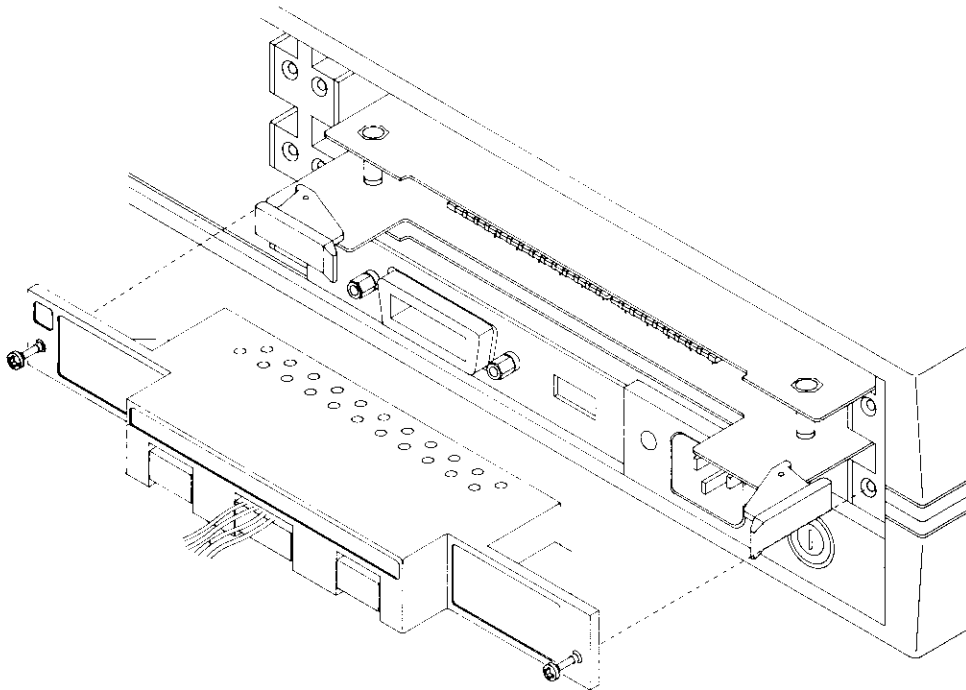

Figure 10-10. Attaching the Terminal Block

5. Labels

- a. Two labels were provided with the option assembly. One identifies the assembly as a 44474A Relay Multiplexer. There is space on the bottom of this label to type or write in a description of where this particular option is being used.
- b. Second, a series of numbered labels (1 to 5) is provided to help you identify the slot where the assembly is located. Select the appropriate numbered label and place it in the upper left hand corner of the strain relief housing.

Accessories

-hp- part number 44484A provides an extra Screw Terminal Connector block for use with the 44474A option.

Specifications

The specifications at the end of the manual apply only to the 44474A option. These specifications are the performance standards or limits against which the option is tested. Do not exceed or surpass these specified limits.

Any changes in specifications due to manufacturing changes, design, or traceability to the National Bureau of Standards will be covered in a manual change supplication.

Applications

The following application examples demonstrate various uses for the 44474A Digital I/O option.

Example 1. Scanning Using External Increment and Channel Closed

Using a voltmeter with internal reading storage (such as the -hp- 3456A) makes the scanning even easier and faster. The main feature of this example is speed because as soon as the voltmeter completes one reading, the next channel is closed and a new reading initiated. Measurement speed is not dependent on the system computer.

Remember to connect the 44470A's common bus's to the voltmeter input terminals and connect the voltmeter's External Trigger to the 3488A's Channel Closed line. Connect the 3456A's Voltmeter Complete to the 3488A's Channel Closed Line.

The program sets the voltmeter for reading storage and then starts the scan sequence. As each reading is taken it is stored internally in the voltmeter and will be available to the computer later.

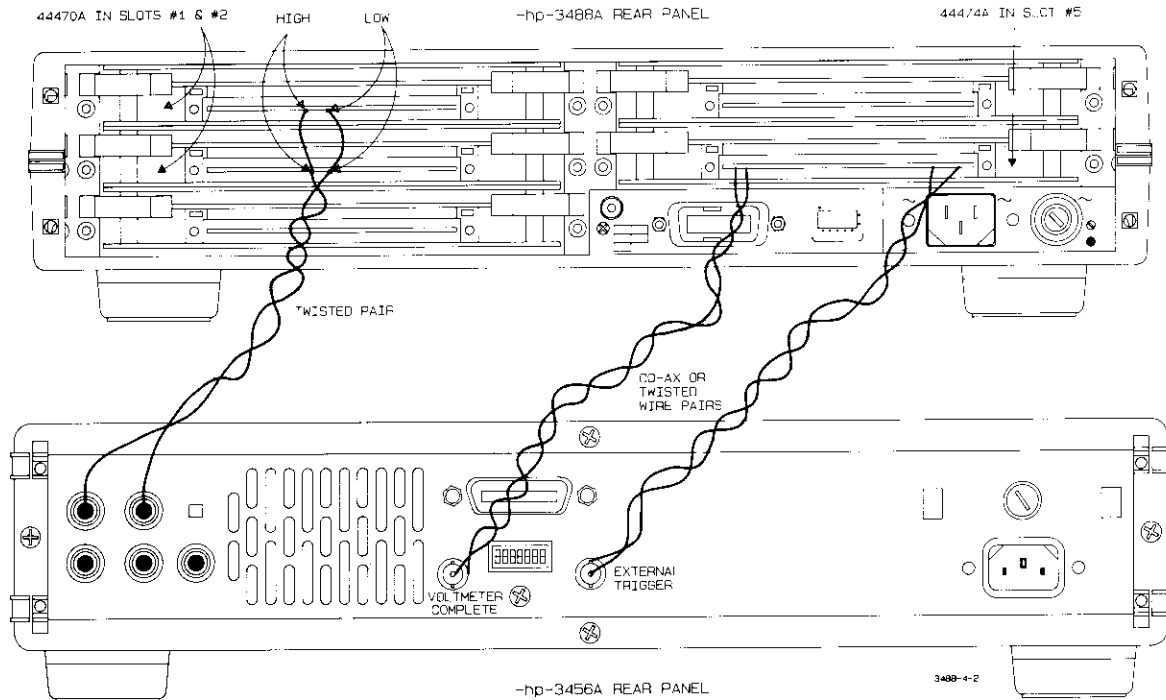

Figure 10-11. External Increment and Channel Closed

```

10 ! End of Scan sequence SRQ e
   xample
20 ! -HP- 85 version
30 ! 3488a at address 709, 3456
   A at address 722
40 ON INTR 7 GOSUB 1000
50 ENABLE INTR 7:8
60 OUTPUT 709 ; "SLIST 100-209.0
   ; DMODE 5.1,0.1; MASK 1"
70 OUTPUT 722 ; "FIR121T2RS1"
80 TRIGGER 709
90 GOTO 90 ! Mainline program e
   oes here
100 END
1000 P=SPOLL(709)
1010 IF BIT(P,0) THEN DISP "END
   OF SCAN REACHED"
1020 OUTPUT 722 ; "0020STR"
1030 FOR I=1 TO 20
1040 OUTPUT 722 ; "RER"
1050 ENTER 722 ; A(I)
1060 DISP A(I)
1070 NEXT I
1080 OUTPUT 722 ; "01"
1090 STATUS 7.1 ; R
1100 OUTPUT 709 ; "STATUS"
1110 RETURN

```

Example 2. Limit Switch Sensing

Figure 10-12 shows one bit of the 44474A wired for use as a digital input. In this example, when the switch is closed or the transistor turns on, the input bit will be closed. By continuously VIEWing that bit, it can be determined when the bit is closed. This is shown in the associated program.

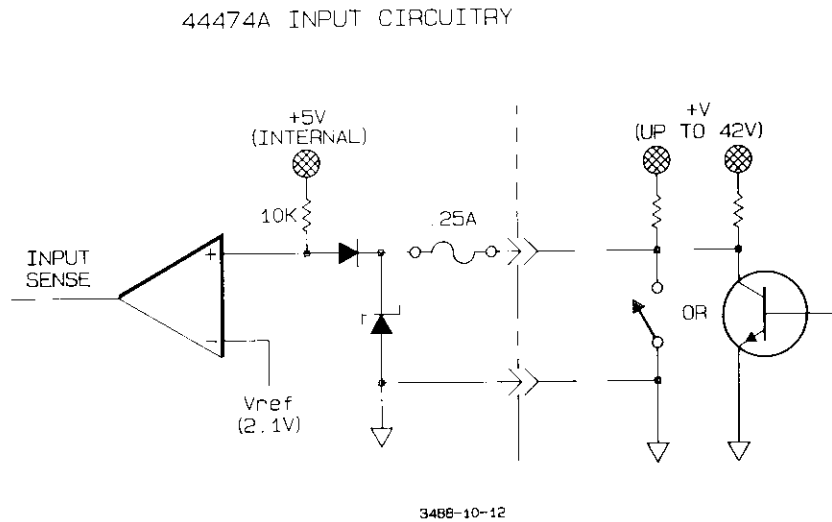

Figure 10-12. Limit Switch Sensing

Table 10-2. Option 014 44474A 16 Bit Digital I/O Module Specifications

I/O LINES

Maximum Voltage = +30V DC (Line-Chassis)

Output Characteristics

$V_{out}(high) \geq 2.4V$ @ $I \leq 8$ mA output
 $V_{out}(low) \leq 0.4V$ @ $I \leq 16$ mA input
 $I_{(low)} = 125mA$ @ $V_{out}(low) \leq 1.25V$
 $I_{(low)}$ fused at 250 mA

Input Characteristics

$V_{in}(high) \geq 2V$; $V_{in}(low) \leq 0.8V$

HANDSHAKE LINES

Maximum Voltage = +5V DC (Line-Chassis)

Output Characteristics

$V_{out}(high) \geq 2.4V$ @ $I \leq 400 \mu A$ output
 $V_{out}(low) \leq 0.5V$ @ $I \leq 2$ mA input

Input Characteristics

$V_{in}(high) \geq 2.0V$; $V_{in}(low) \leq 0.8V$

External Increment: Advances 3488A to next programmed configuration on falling edge of TTL pulse, 0.25 μ sec minimum width.

Channel Closed: Indicates completion of new configuration; TTL pulse, 10 μ sec minimum width.

Chapter 11

44475A

Breadboard Assembly

Introduction and Description

This chapter provides the technical information necessary for the design engineer or technician to use the -hp- Model 44475A Breadboard option with a -hp- 3488A Switch/Control Unit. This chapter is not intended for use by operator (non-technical) individuals.

Mechanical parts supplied with the 44475A Breadboard are shown in Figure 11-1.

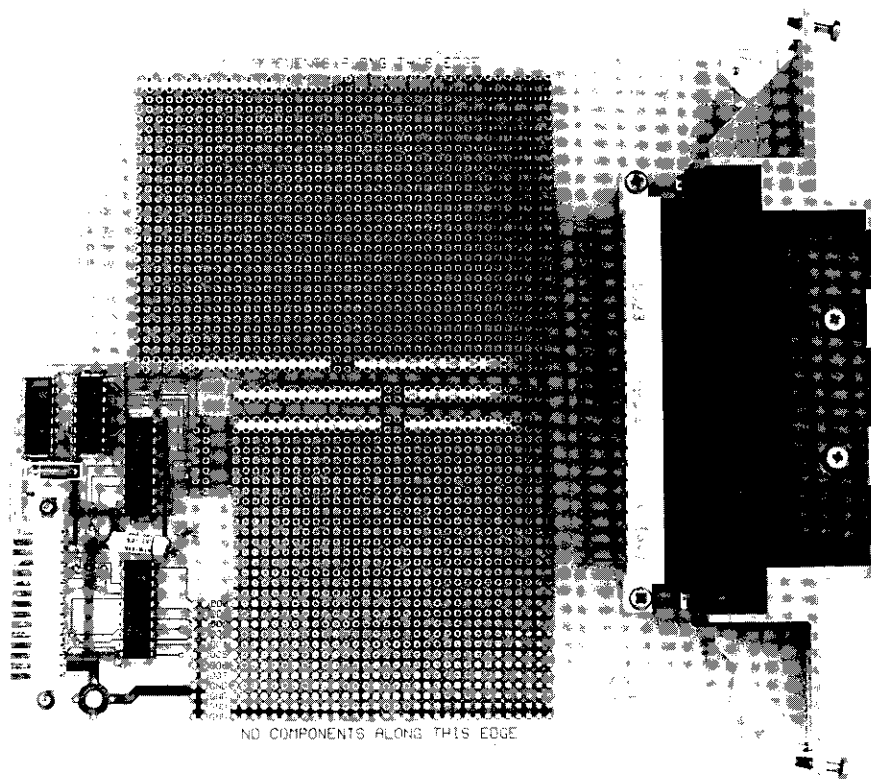

Figure 11-1. 44475A Breadboard

As shown in Figure 11-1, the 44475A Breadboard Option consists of two areas. These two areas are:

1. Breadboarding Grid consisting of holes on 0.10'' centers. There is a 0.030'' spacing between foil pads. Bus traces for power supply and ground, and provisions for the terminal Block Edge Connector.

2. Built in design (you must supply components) for providing an 8-bit digital input port and an 8-bit digital output port. Two commands are used to control the input and output ports, these are discussed later in this manual.

At the end of this chapter are two pages, each showing a full size view of both front and back sides of the 44475A Breadboard Assembly. These pages are provided to assist you in designing and laying out your circuits. You may want to tear one out and duplicate for future use.

Warranty

The Breadboard Option Warranty statement, located in Chapter 5, is different than the standard -hp- warranty statement. While -hp- is responsible for defects in material and workmanship of the blank circuit card and supplied hardware, -hp- is not responsible for the performance of the customers circuit. In addition, -hp- is not responsible for damage or improper operation of the 3488A or other plug-in options when the breadboard is installed.

Getting Started

Before designing and mounting any circuit on the breadboard, familiarize yourself with the interface circuitry on the two Breadboard ports. Also, the following list provides precautions and helpful hints to follow:

- * Observe all WARNINGS and CAUTIONS.
- * Make sure to observe all power supply, and wattage dissipation limitations.
- * Observe the component height/protrusion restrictions.
- * Avoid mounting components along the extreme edges of the circuit board.
- * Keep in mind that other option assemblies share the same 3488A backplane signals as your Breadboard. Use the recommended interface circuitry.

Specifications

Figure 11-2 shows the dimensions of the 44475A Breadboard Option including:

- Overall Length
- Height
- Grid hole spacing (center to center)
- Grid hole size (inside diameter)
- Component height/protrusion restrictions

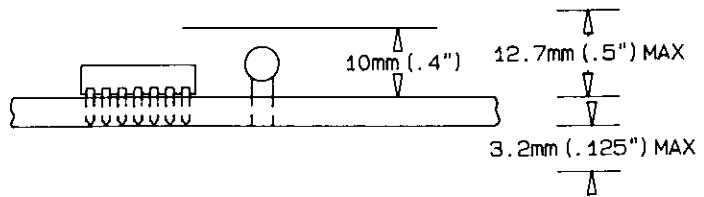
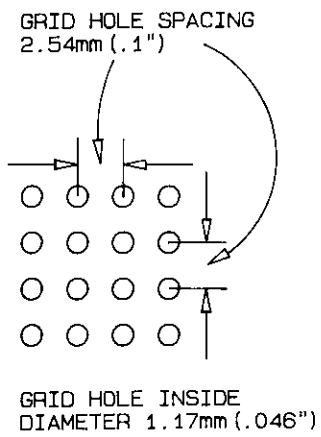
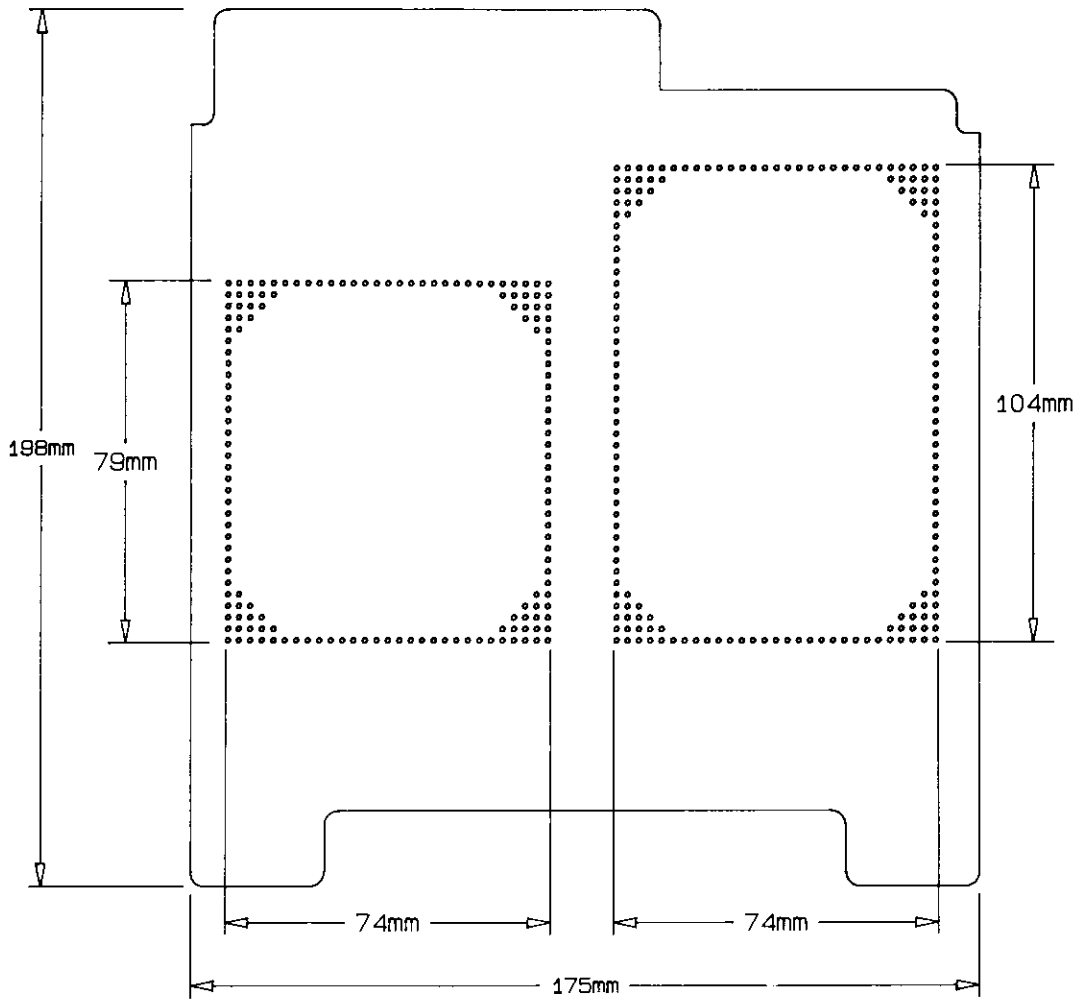

Figure 11-2. 44475A Breadboard Option Dimensions and Component Height/Protrusion Restrictions

Maximum Power dissipation: 2 watts

Maximum input voltage on Digital Input Port lines: 5.5 Volts

Power supply:

No power supply is provided from the 3488A to the breadboard grid area. Adequate power supplies must be provided by the user. A +5 volt supply is provided only for use with the 8-bit input and 8-bit output ports.

Maximum voltage on breadboard area: 42 VDC, 30 VACrms, 42 VACpeak

Assembling the Breadboard

Three steps are involved in assembling the 44475A Breadboard. The first step is to load the components (if your task requires them) for the 8-bit Input and 8-bit Output port. Components were not supplied for these ports.

Second, you will need to install your custom circuitry. Guidelines for doing this are given after a discussion on the I/O ports.

The third step is assembling the hardware supplied with the Breadboard. These parts are listed in Table 11-2.

Loading the Components

Components required, but not supplied, to use the 8-bit input and output ports are listed in Table 11-1. Figure 11-3 shows where these components are to be mounted on the Breadboard. Refer to the manufacturers data sheet for load/drive specifications for the ports. A schematic diagram for the two ports is shown in Figure 11-4.

Table 11-1. Required Components For 8-bit I/O Ports

Quantity	Description
1	SN74LS138; 3 to 8 line decoder
1	SN74LS157; Quad 2 line to 1 line data Selector/Multiplexer (noninverted data outputs)
1	SN74LS244; Octal Buffers, line drivers, line receivers (noninverted 3-state outputs)
1	SN74LS374; Octal D-Type Flip-Flops (3-state outputs)
1	.01 μ F Capacitor, 10 volts
1	1 μ F Capacitor, 10 volts

CAUTION

Only Qualified service trained personnel should install or configure the breadboard assembly. Make certain that all power is removed from the breadboard before installing components. Use clean handling techniques and antistatic precautions.

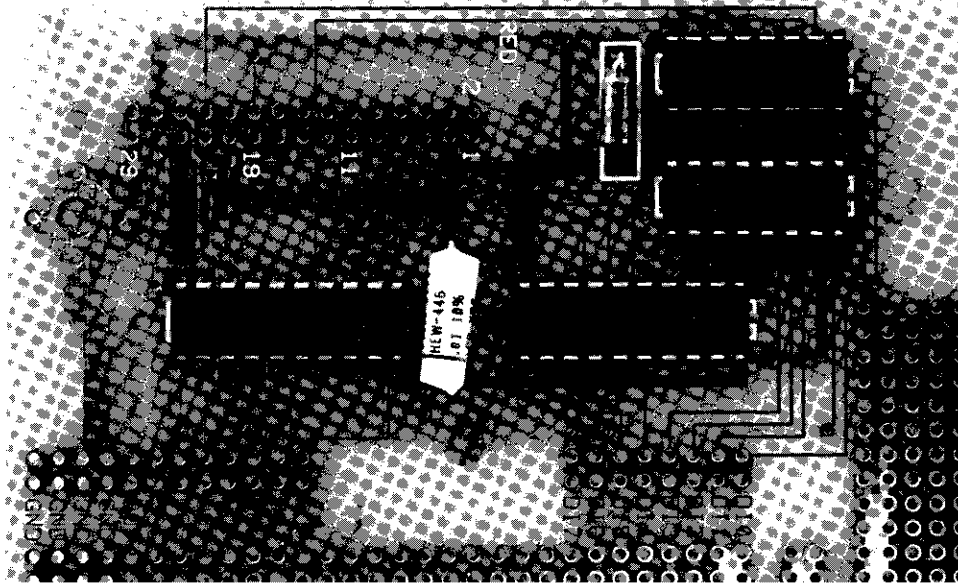

Figure 11-3. Component Mounting

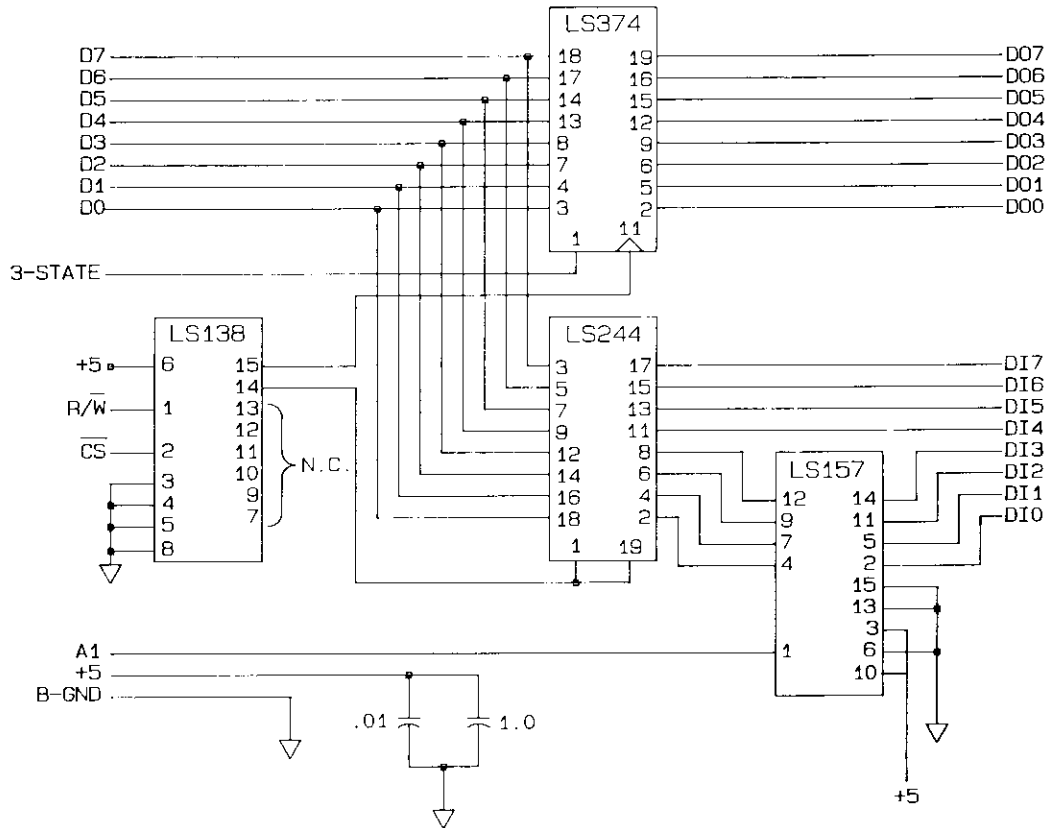

Figure 11-4. Breadboard Schematic

Mounting Your Custom Circuitry

This section of the chapter provides helpful guidelines for installing components on the 44475A Breadboard. Use the two full size photographs at the end of the chapter as an aid in laying out your custom circuitry.

Component Height/Protrusion Restrictions

Component height restrictions and how far the component leads extend through the circuit board are limited by the top and bottom shields. These shields must never be eliminated as they provide RF shielding as well as structural strength.

The absolute maximum component height allowed is 12.7 mm (0.50 in.). However, if the height of any component exceeds 10 mm, the conductive surface of the component must be insulated. On the circuit side of the Breadboard, the lead lengths are limited to 3.2 mm (0.125 in.) from the circuit board.

Using Wire-Wrap Components/Long Lead Length

Most Wire-Wrap components, such as IC sockets, will protrude through the circuit board further than the restrictions allow. When using such components make sure to cut the lead lengths to meet the restrictions noted in Figure 11-2.

Breadboard Top and Bottom Edges

Never mount components where they will occupy space along the extreme top and bottom edges of the circuit board. This space is needed to slide the breadboard into the grooves of the slot.

Power Supply and Ground Traces

Be careful to mount components so they are not across the power supply or ground traces.

Soldering

When soldering components on the breadboard, use a soldering iron with a 25 Watt (or less) rating and rosin core solder. Use of acid core solder will void the warranty.

Assembling the Hardware

Table 11-2 lists the hardware supplied with the 44475A Breadboard. Refer to the paragraphs following and Figure 11-5 for assembly information.

Table 11-2. Parts Supplied With the 44465A Breadboard

Part Number	Qty.	Description
44475-27501	1	Breadboard circuit board
03488-00602	1	Bottom Shield
03488-00603	1	Top shield (component side)
1251-8645	1	2 rows × 15 pins right angle connector (small connector)
44475-62102	1	2 rows × 11 pins right angle connector (large connector)
44475-62101	1	Terminal Block, keyed for the breadboard connector
5040-5193	1	Connector Housing
5040-5194	1	Cable Clamp
0515-0063	2	Pan Head screw, 2.5 × 12 (metric)
0515-0843	4	Flat Head screw, 2.5 × 20 Lock (metric)
0515-0845	2	Pan Head screw, 3 × 18 Lock (metric)
0535-0004	2	Hex Nut, 3 × .5
0535-0008	2	Hex Nut, 2.5 × .45
2190-0583	2	Lock Washer
2190-0584	2	Lock Washer

Refer to Figure 11-5. Mount the smaller (2 × 15 connectors) on the component side of the breadboard. Make certain that all pins are through the circuit board before soldering the pins. Use a low wattage (25 watts maximum) soldering iron and rosin core solder. This connector should be installed whether you intend to use the 8-bit I/O ports or not.

Next, mount the large connector (2 × 11 connectors). This large connector is specifically keyed to fit only the terminal block supplied with the Breadboard. Additional terminal blocks can be purchased using the part number 44485A. Again, make certain that all pins are through the circuit board before soldering. Also, be sure to firmly tighten the mounting screws before soldering the pins. This will help ensure that the circuit board is not bowed when soldering.

At this point you should mount your custom circuitry, making connections to the 8-bit I/O ports and the large connector. Make certain that all components and wiring do not exceed the height and protrusion specifications listed earlier in this chapter.

Attach the top and bottom shields as shown in Figure 11-5. Check for proper orientation of the shields before assembling.

NOTE

Under no circumstances should the shields be left off. The shields are used to reduce RFI (they connect to chassis ground, They are insulated to prevent arcing from adjacent circuitry, and they also provide some structural support.

Breadboard Installation

- a. Remove the ac power cord from the 3488A before installing or removing any option assembly.
- b. Position the rear panel of the 3488A towards you.
- c. Select a slot. Refer to Figure 11-6; the 3488A has five slots for installing option assemblies. the 44475A Breadboard may be installed in any of the five slots.

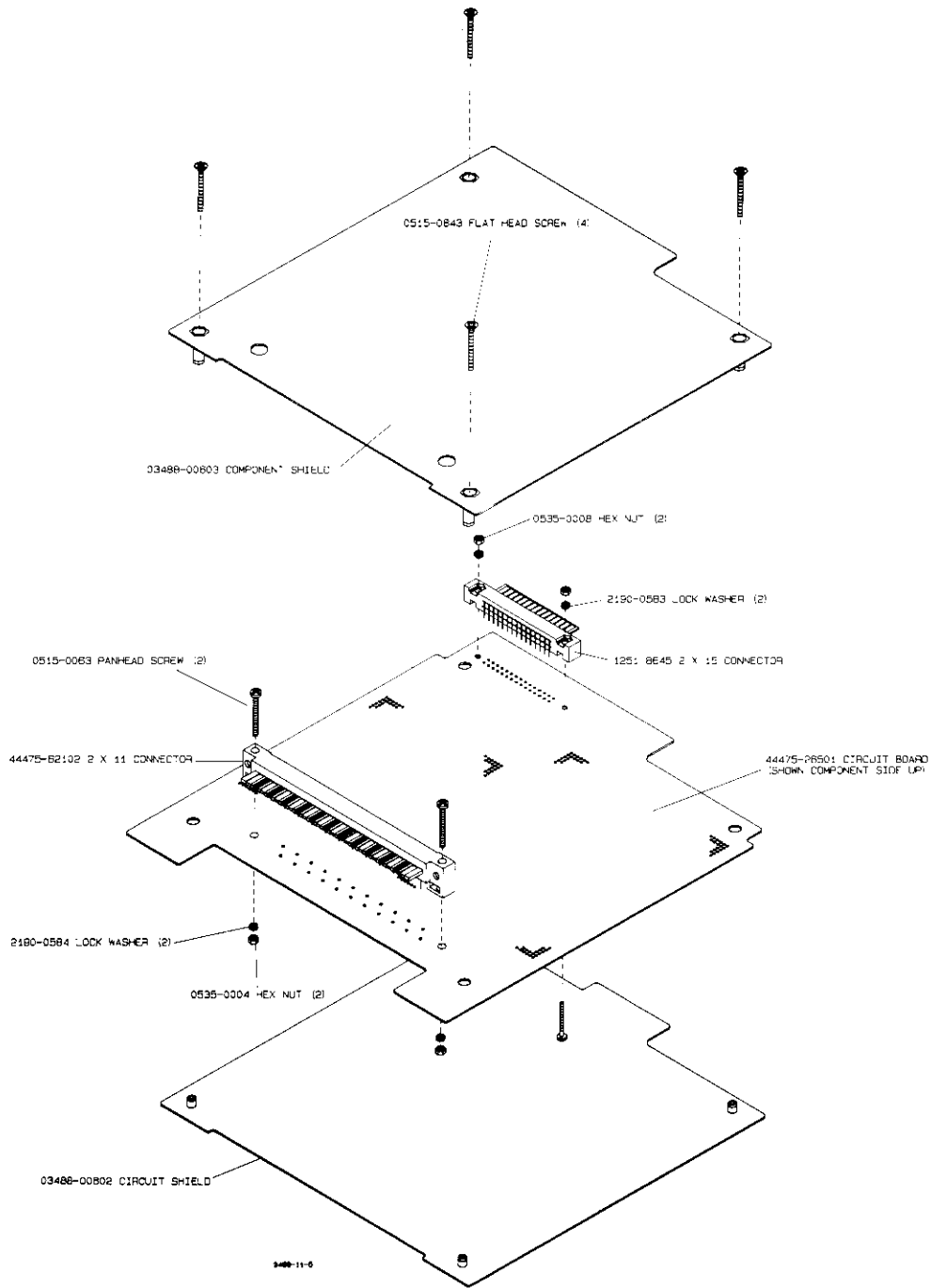

Figure 11-5. Hardware Assembly

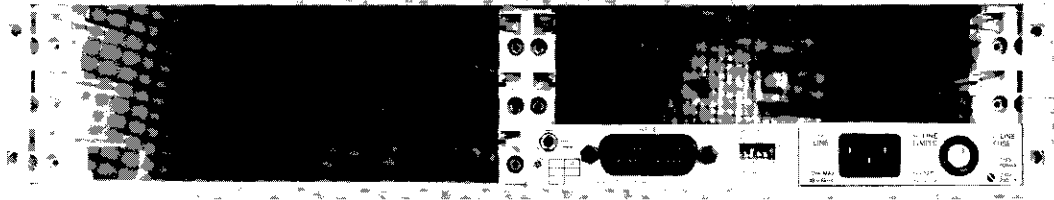

Figure 11-6. Rear Panel of the 3488A

d. Hold the assembled module, component side down, by the metal shields. Insert the circuit card into the slot guides and slide toward the front of the 3488A. Push firmly until the assembly 'snaps' in place. Fold the plastic levers toward the assembly. these levers lock the option into the mainframe.

NOTE

To remove an option assembly, simply unfold the the plastic levers. This will release the locking mechanism and pull the option out pf the mainframe connector.

Terminal Block

a. Wire the terminal block to fit your custom circuit. This terminal block is keyed to fit only the 44475A Breadboard. Extra teminal blocks are available under the -hp- part number 44485A. This terminal block is designed to accept wires in the range of 18 to 26 AWG.

b. Secure the terminal block to the strain relief housing with the captive screws on the terminal block. Make certain that the screws used to tighten the connecting wires inside the terminal block are accessible through the strain relief housing.

c. Route the wires evenly through the three strain relief cutouts. This will ensure a uniform amount of strain relief. If only a few wires are used, they should go through the middle cutout.

d. To protect wires smaller than 22 AWG it is recommended that these wires be bundled together starting no more than 4'' from the back of the 3488A. Failure to do so may cause wires to break at the strain relief. To illustrate the need for this, a 26 AWG wire can survive about 7 to 8 pounds of tension before breaking. A bundle of 10, however, could survive up to 70 pounds of tension.

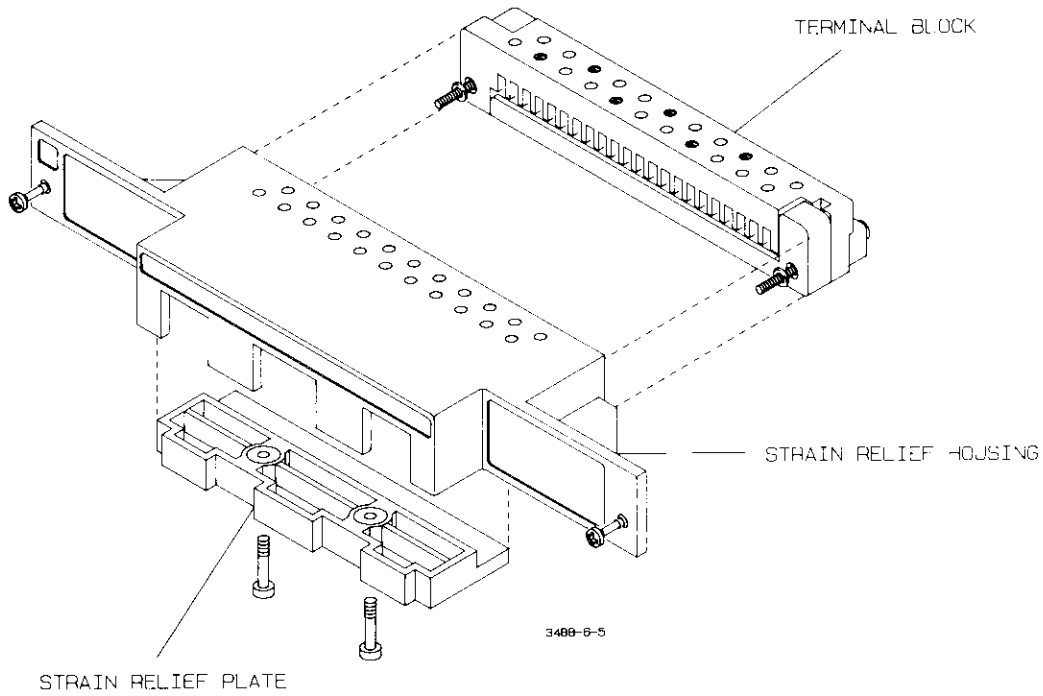

Figure 11-7. Strain Relief Housing



Figure 11-8. Cable Routing

e. Secure the strain relief plate to the strain relief housing (ribbed side toward the housing). Do not overtighten.

f. Push the terminal block with strain relief housing onto the the option assembly connector. Tighten the two screws on either end of the housing.

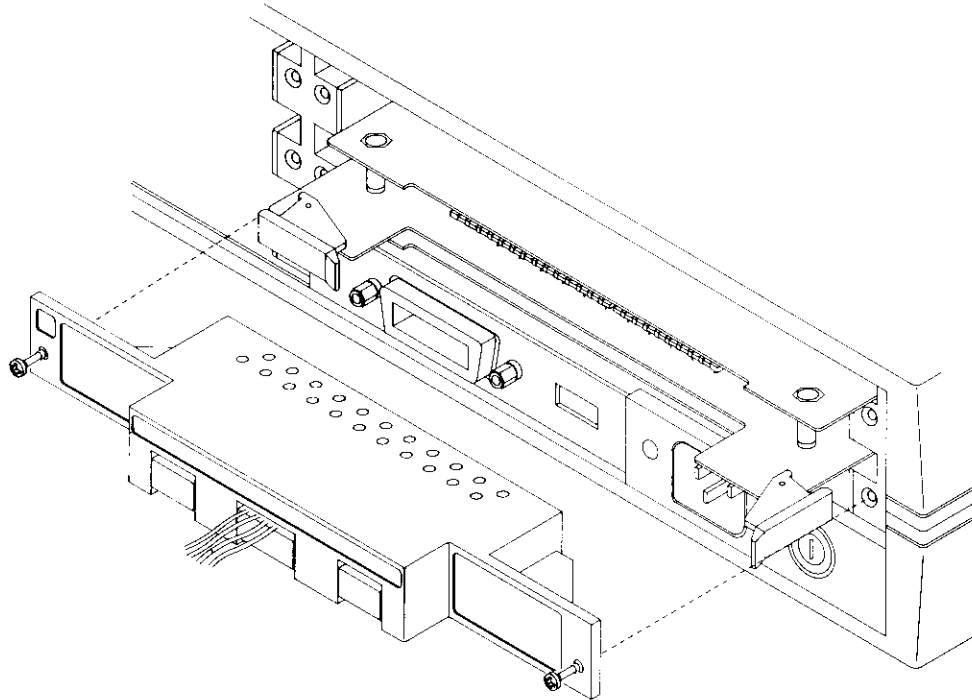

Figure 11-9. Attaching the Terminal Block

g. Two labels were provided with the option assembly. One identifies the assembly as a 44475A Breadboard. There is space at the bottom of this label to type or write in a description of the circuit installed on this breadboard.

h. Second, a series of numbered labels (1 to 5) is provided to help you identify where the assembly is installed. Select the appropriate number for the slot where the assembly is installed and place the label in the upper left hand corner of the strain relief housing.

Controlling the Breadboard Ports

Two 8-bit ports are available on the 44475A Breadboard. One port is a static read only port, the second port is static write only. Static means that there is no hand-shaking involved in data transfers. Use of the two ports requires that the components specified in the Assembly section be installed on the Breadboard.

Two commands are used to control the Breadboard; SREAD reads data from the input port and SWRITE writes data to the output port.

SREAD Command

The SREAD command uses the format: SREAD #04 where the # symbol represents the slot number where the 44475A Breadboard is installed. For example, if the Bread-

board is installed in slot 2, the command would be: SREAD 204. The number 04 specifies the Read register in the Breadboard circuitry. If a number other than 04 is used (any number between 0 and 7 will not cause an error), the value 255 will be returned, thus indicating a floating input. Data read back is in the form of a decimal number which is the sum of the binary weighted values of the bits that are high (+5 volts).

The following chart shows the bit values for the eight input bits:

Bit Number:	7	6	5	4	3	2	1	0
Value if high:	128	64	32	16	8	4	2	1

Example

```
10 OUTPUT 709; "DREAD 304"      ! BREADBOARD IN SLOT 3
20 ENTER 709; A
30 DISP A
```

If the data value read back were, for example, 46, it would indicate that bits 5 (value 32), 3 (value 8), 2 (value 4) and 1 (value 2) are in a high (+5 volt) state. Note that the sum of the values totals 46 ($32 + 8 + 4 + 2 = 46$). All remaining bits are in a low (ground) state.

SWRITE Command

The SWRITE command uses the format: SWRITE #00,<data>. Just as with with the SREAD command, the # symbol represents the slot number where the Breadboard is installed. The number 00 specifies the write or output port on the breadboard. Any number between 1 and 7 may be used without causing an error, however no action will be taken by the breadboard.

The data value is a decimal sum of the binary weighted values of the bits that are to be set high (+5 volts). Refer to the bit value chart under the SREAD command for bit value information.

External pull-up resistors are not required when using the output port because the integrated circuit driver uses Totem-Poll outputs. Do not exceed the current drive capacity of the IC.

Example

To set bits 1, 4, and 7 on the output port (bit values 2, 16 and 128 respectively, sum = 146), execute the command: SWRITE 500,146. Note that the Breadboard is installed in slot 5 for this example.

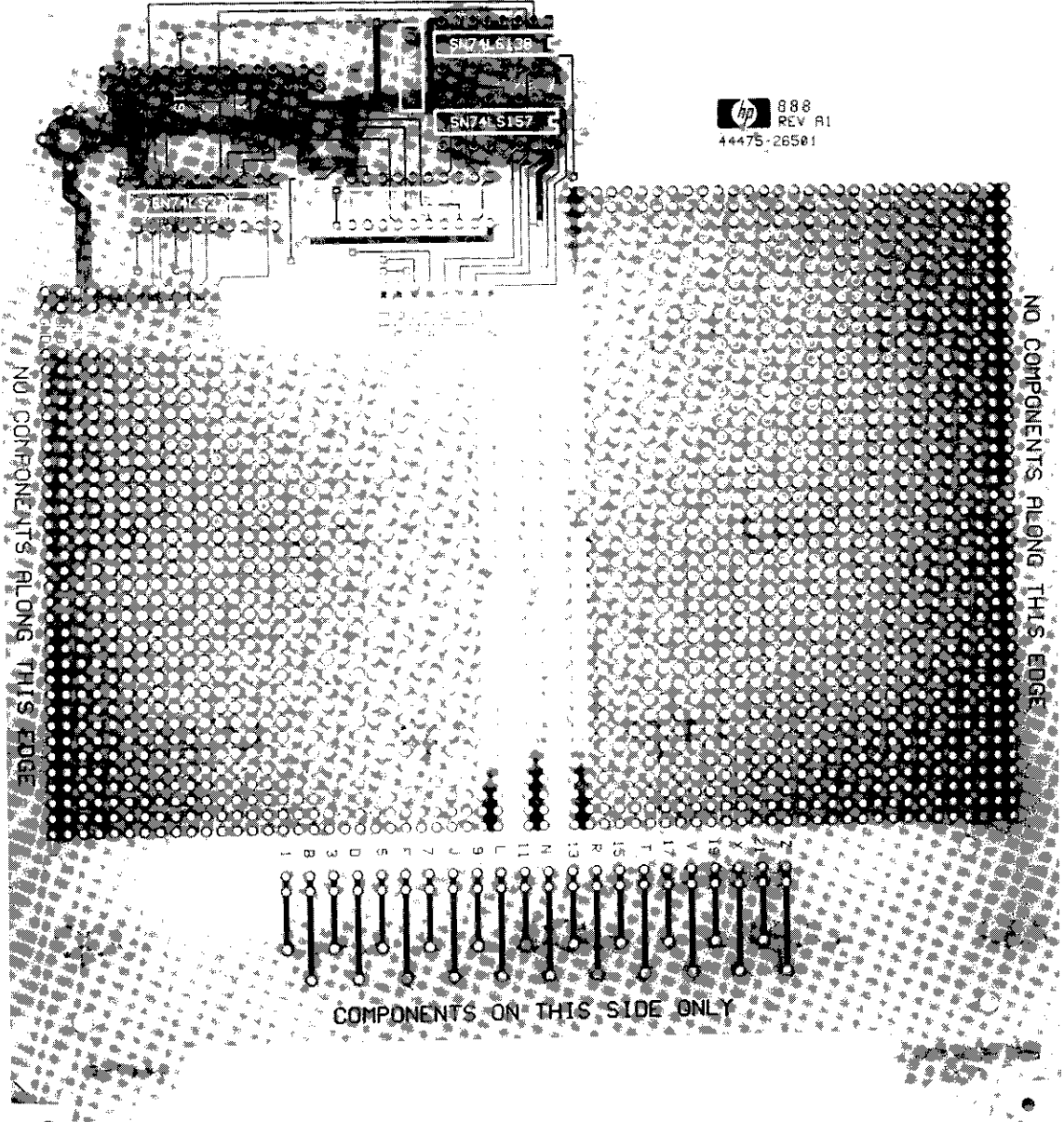

hp 888
REV A1
44475-26581

NO COMPONENTS ALONG THIS EDGE

NO COMPONENTS ALONG THIS EDGE

1 B 3 D 5 F 7 J 9 L 11 N 13 R 15 T 17 A 19 X 20

COMPONENTS ON THIS SIDE ONLY

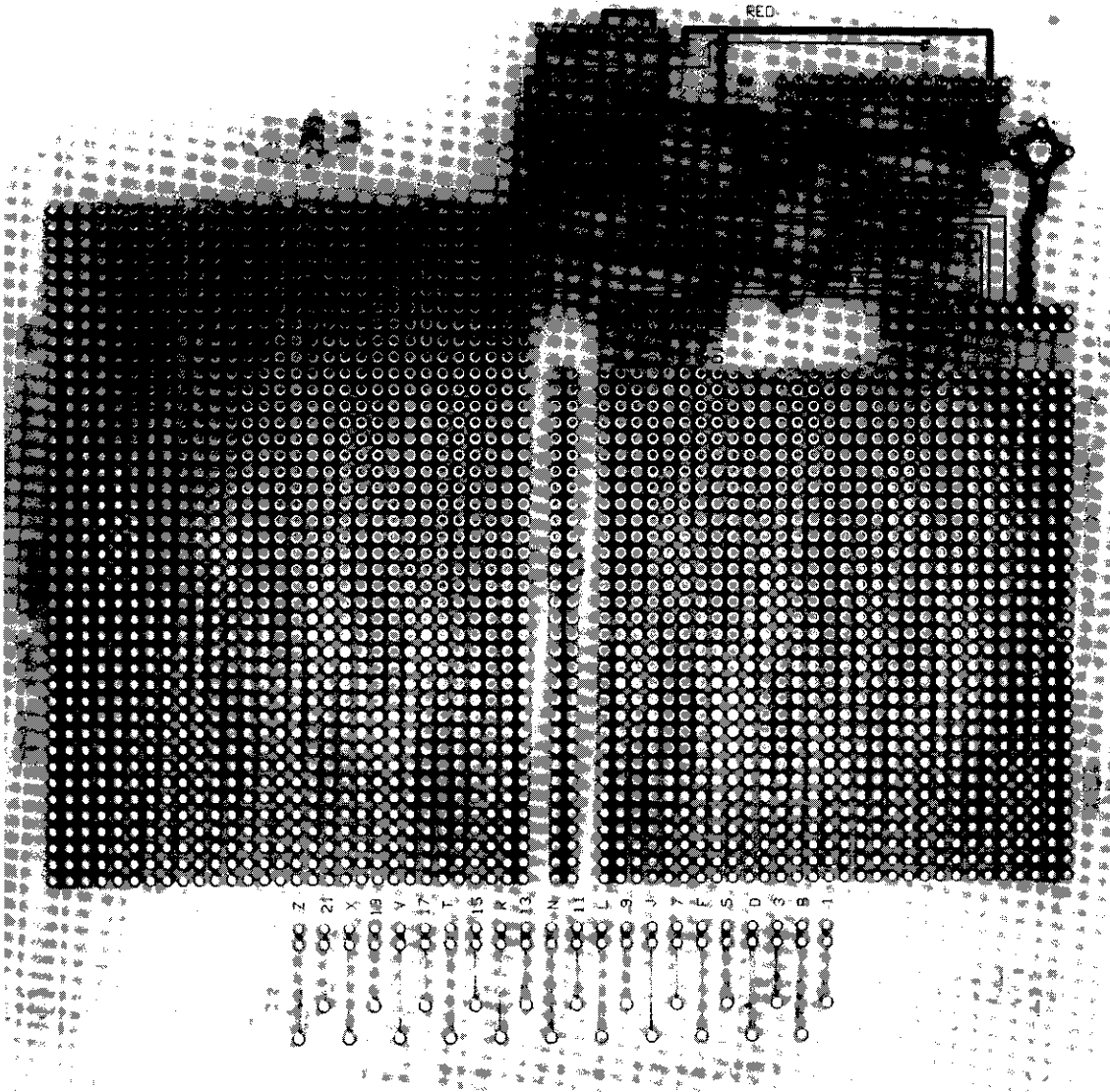

BREADBOARD
MODULE

44475A

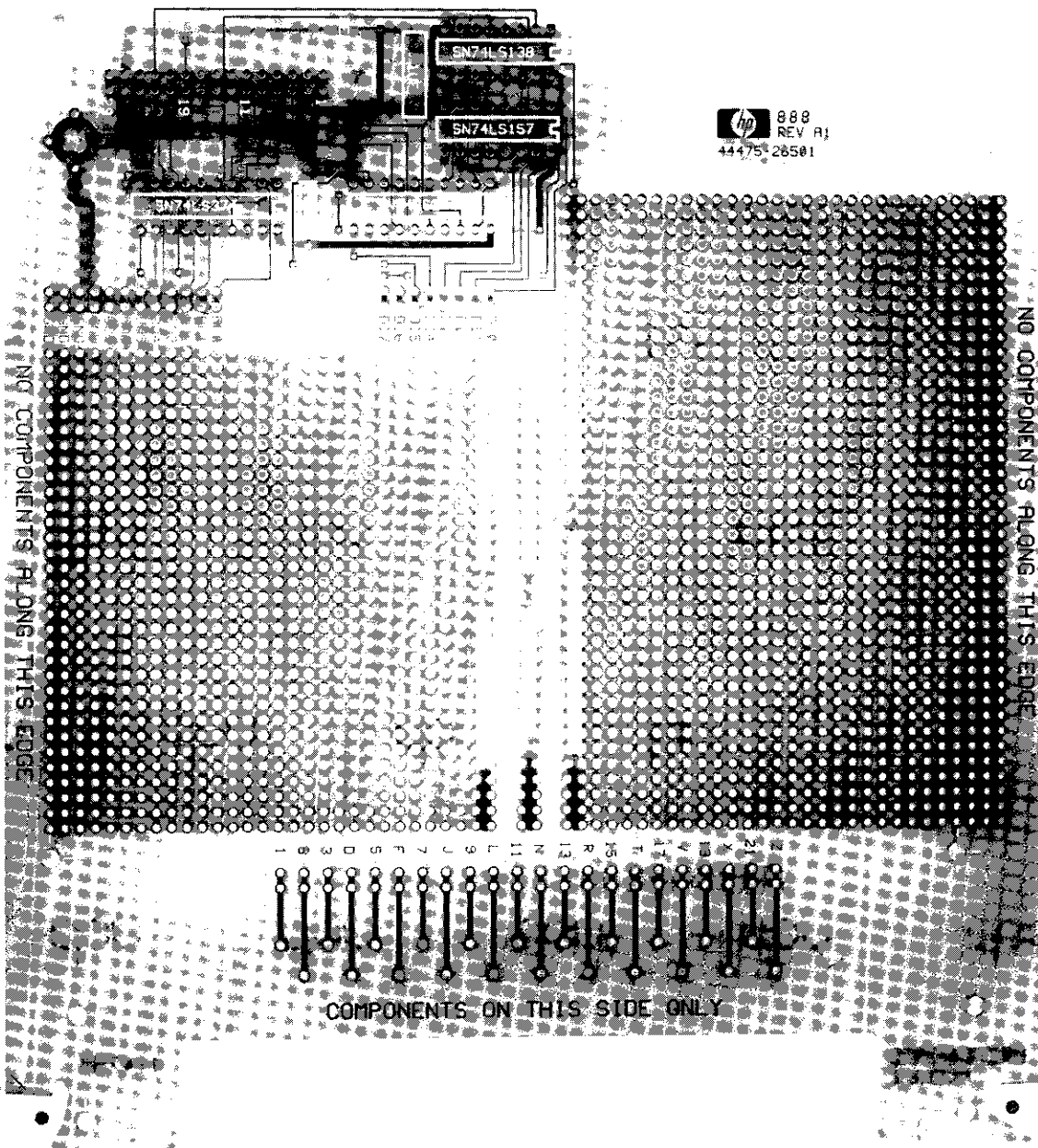

hp 888
REV A1
44475 28581

NO COMPONENTS ALONG THIS EDGE

NO COMPONENTS ALONG THIS EDGE

1
2
3
4
5
6
7
8
9
10
11
12
13
14
15
16
17
18
19
20
21
22
23
24

A
B
C
D
E
F
G
H
I
J
K
L
M
N
O
P
Q
R
S
T
U
V
W
X

COMPONENTS ON THIS SIDE ONLY

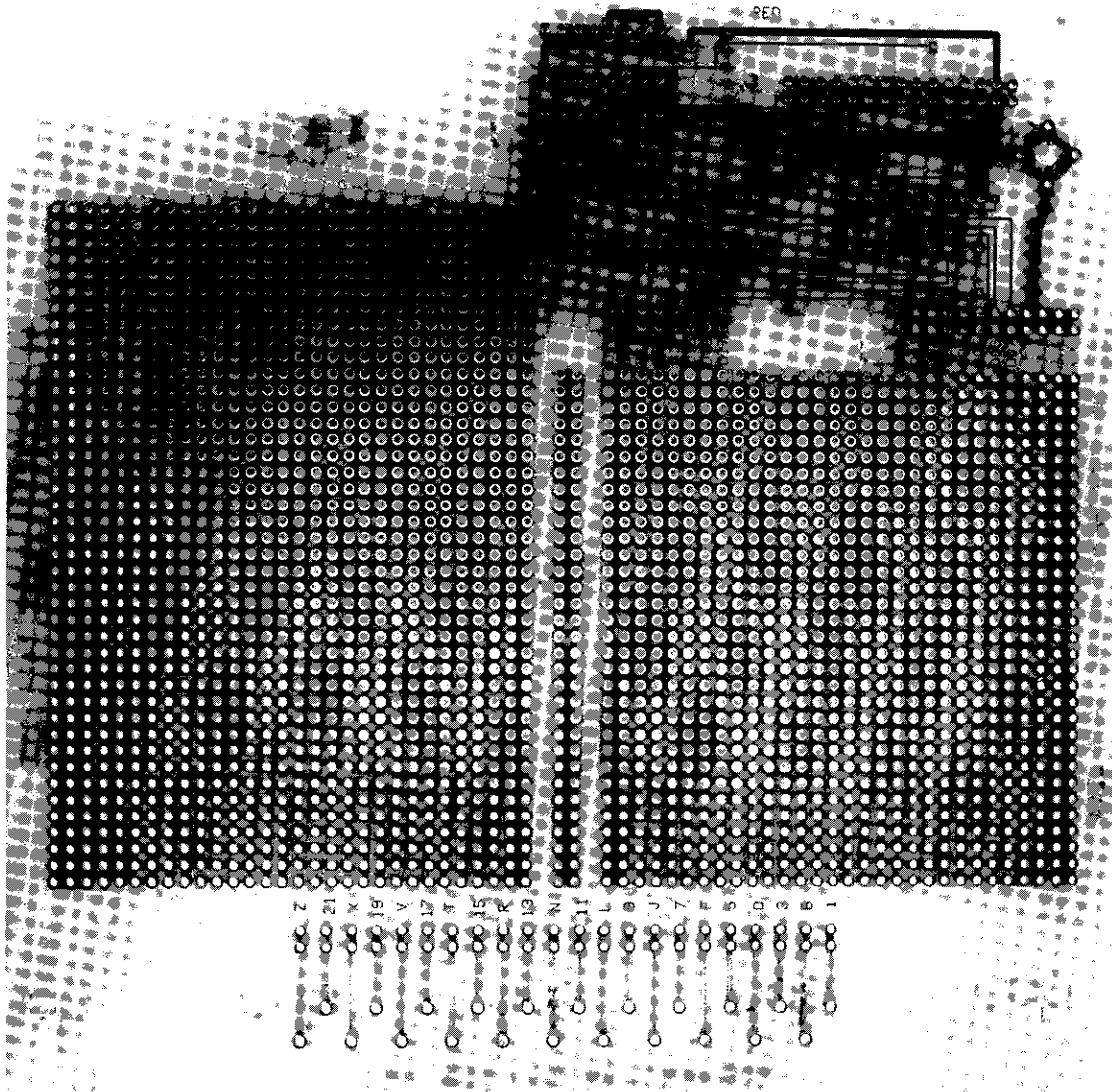

BREADBOARD
MODULE

44475A

Appendix A

Documentation Worksheet

Introduction

In any test system where you have a multitude of cables running from the test fixture to the measurement system, it is beneficial to document the system configuration. This will be especially beneficial later if you're attempting to diagnose system failures. This appendix presents a simple method of documenting your test system to help in the setup and wiring procedure as well as diagnostics. Only two worksheets are provided, therefore you may want to tear one out and duplicate it for future use.

Worksheets

While the test system is being configured and wired, you will want to fill out these Documentation Worksheets. Later, they can be used as a guide when debugging and writing computer programs for the test system. Instructions for completing the worksheets are found on the back of the worksheets.

These worksheets serve only as a guide for your system and need not be restricted to cabling associated with the 3488A. In other words, modify the worksheets to fit your own individual needs. Figure A-1 shows some examples of how the Worksheets may be filled out and the associated computer program. The program was developed using the worksheet as a guide.

Date/Time	System Name:		Test Area:			
3488A Slot/Card Type	Card Terminals	Channel	From	To	Typical Values	Comments
Slot 1 Relay mux	00	100		3478 DVM Through Cm.	+5 ±.5%	Measure Power Supplies
"	01	101		"	+12V	" " "
"	02	102		"	-12V	" " "
Slot 5 Digital I/O	100	Pin 00	Out. DUT TEST 31-A			USED AS INPUT BITS FOR
"	101	"	" 31-B			DISPLAY TEST
"	102	"	" 31-3			"
Slot 3 4x4 MATRIX	Row 1	31x	D.V.M.			
Slot 3 4x4 MATRIX	Col 2	3x2		D.V.T. Test Point A		
"	Row 0	30x	Counter			
"	Col 1	3x1		D.V.T. TEST Point B		
Slot 2 GP Relay	00	200		D.V.T. A1	120 VAC	Power Actuators For
"	01	201		D.V.T. A2	+27 VDC	Device Under TEST TERMINALS
"	02	202		D.V.T. A3	-15 VDC	A1, B1, C1

Figure A-1. Worksheet Examples

Event Log

In addition to the Worksheets, you may want to maintain an Event Log. Types of Event Log entries include changes in the computer program, changes in the system setup, instrument calibration times, a record of down times, etc. Each entry should include at least the following:

1. What the event was and the extent of change.
2. Where the event took place or was observed.
3. When the occurrence happened or was noticed.
4. The fix.

Another piece of documentation you may find useful is a single page cover sheet to identify the documentation package. This cover sheet might incorporate a list of all instruments in the test system. This list should include both model and complete serial numbers. Also, you may want to include instrument calibration cycles, names and phone numbers of who to call in case of failures, etc.

This complete documentation package will contain a complete history of your test system. With it you can save both time and money because answers are available immediately.

DOCUMENTATION WORKSHEET INSTRUCTIONS

DATE/TIME: Indicate the date and time of the original setup here. Dates and/or times of minor alterations should be made in the left hand margin next to the addition or alteration.

SYSTEM NAME: The system name is used to identify a particular test system. This is especially important when more than one system is in use.

TEST AREA: This is an overall description of where the test system is being used or what it is measuring.

3488A SLOT/CARD TYPE: Refer to chapters 1 and 2 of this manual for a discussion of the 3488A slots and card types. The slot number as well as what type of 3488A option assembly is in that slot must be known when writing the test program.

CARD TERMINALS: Record the terminal block connector numbers for each connection. As a diagnostic aid it is important to record the terminal connections.

CHANNEL: This entry is the channel number that you will specify in the test program.

FROM - TO: Each channel on the 3488A will have some destination. Keep in mind the different types of options when filling in these two areas. For example, with the 10 Channel Multiplexer assembly, each channel may go to a different voltage source but the entire block will go to a voltmeter or other measurement device. Therefore, the FROM column might indicate the particular voltage source and the TO column could show the destination of the entire block, i.e. the voltmeter.

TYPICAL VALUE: Indicate the type of signal being switched and (if possible) its typical value.

COMMENTS: This entry should include anything not already specified that might be appropriate to the test. Possible entries include specific locations of test points, test limits, etc.

DOCUMENTATION WORKSHEET INSTRUCTIONS

DATE/TIME: Indicate the date and time of the original setup here. Dates and/or times of minor alterations should be made in the left hand margin next to the addition or alteration.

SYSTEM NAME: The system name is used to identify a particular test system. This is especially important when more than one system is in use.

TEST AREA: This is an overall description of where the test system is being used or what it is measuring.

3488A SLOT/CARD TYPE: Refer to chapters 1 and 2 of this manual for a discussion of the 3488A slots and card types. The slot number as well as what type of 3488A option assembly is in that slot must be known when writing the test program.

CARD TERMINALS: Record the terminal block connector numbers for each connection. As a diagnostic aid it is important to record the terminal connections.

CHANNEL: This entry is the channel number that you will specify in the test program.

FROM - TO: Each channel on the 3488A will have some destination. Keep in mind the different types of options when filling in these two areas. For example, with the 10 Channel Multiplexer assembly, each channel may go to a different voltage source but the entire block will go to a voltmeter or other measurement device. Therefore, the FROM column might indicate the particular voltage source and the TO column could show the destination of the entire block, i.e. the voltmeter.

TYPICAL VALUE: Indicate the type of signal being switched and (if possible) its typical value.

COMMENTS: This entry should include anything not already specified that might be appropriate to the test. Possible entries include specific locations of test points, test limits, etc.

Appendix B

HP-IB

Introduction

An interface is the means by which a computer and the 3488A or other instruments communicate. This appendix provides a more detailed overview of the HP-IB interface used with the 3488A. Although the information in this appendix is computer independent, much of the information is 3488A dependent.

General HP-IB Description

The Hewlett-Packard Interface Bus (HP-IB) is Hewlett-Packard's implementation of IEEE Standard 488-1978, "Standard Digital Interface for Programmable Instrumentation." HP-IB is a carefully defined interface which simplifies the integration of various instruments and computers into systems. The interface provides for messages to be transferred between two or more HP-IB compatible devices.

HP-IB is a parallel bus of 16 active signal lines grouped in three sets, according to function, to interconnect up to 15 devices. A pictorial view of the HP-IB connector and its pin designations are shown in Figure B-1. Also shown is a diagram of the interface connections and bus structure.

Eight signal lines, termed DATA lines, are in the first function set. The DATA lines are used to transmit data in the form of coded messages. These messages are used to program the instrument function, transfer measurement data, and coordinate instrument operation. Input and Output of all messages, in bit parallel - byte serial form, are also transferred on the DATA lines. A 7-bit ASCII code normally represents each piece of data.

Data is transferred by means of an interlocking "handshake" technique which permits data transfer (asynchronously) at the rate of the slowest active device used in that transfer. The three DATA BYTE CONTROL lines coordinate the handshaking and form the second functional group.

The remaining five GENERAL INTERFACE MANAGEMENT lines (third functional group) are used to manage the devices connected to the HP-IB. This includes activating all connected devices at once, clearing the interface, and others.

PIN	LINE
1	D101
2	D102
3	D103
4	D104
13	D105
14	D106
15	D107
16	D108
5	E01
17	REN
6	DAV
7	NRFD
8	NDAC
9	IFC
10	SRQ
11	ATN
12	SHIELD-CHASSIS GROUND
18	P/O TWISTED PAIR WITH PIN 6
19	P/O TWISTED PAIR WITH PIN 7
20	P/O TWISTED PAIR WITH PIN 8
21	P/O TWISTED PAIR WITH PIN 9
22	P/P TWISTED PAIR WITH PIN 10
23	P/O TWISTED PAIR WITH PIN 11
24	ISOLATED DIGITAL GROUND

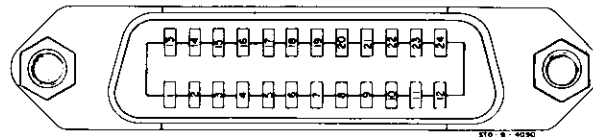

CAUTION

The 3488A contains metric threaded HP-IB cable mounting studs as opposed to English threads. Metric threaded -hp- 10631A, B, or C HP-IB cable lockscrews must be used to secure the cable to the instrument. Identification of the two types of mounting studs and lockscrews is made by their color. English threaded fasteners are colored silver and metric threaded fasteners are colored black. DO NOT mate silver and black fasteners to each other or the threads of either or both will be destroyed. Metric threaded HP-IB cable hardware illustrations and part numbers follow.

THESE PINS ARE INTERNALLY GROUNDED

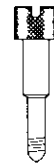

LOCKSREW
1390-0360

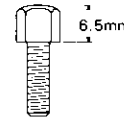

LONG MOUNTING STUD
0380-0643

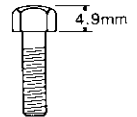

SHORT MOUNTING STUD
0380-0644

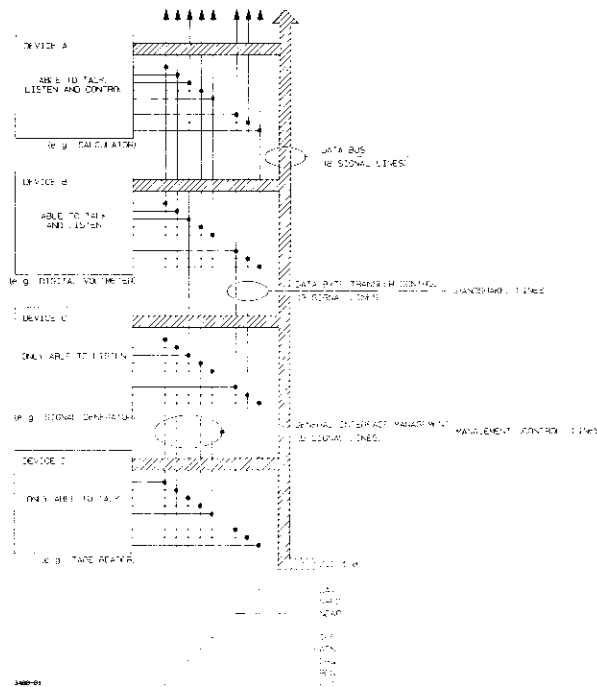

Figure B-1. HP-IB Interface

For a detailed description of the HP-IB lines, commands, internal operations, etc., refer to the HP-IB Abbreviated Description Manual, -hp- part number 5955-2903. A condensed description is also available in the Condensed Description of the Hewlett-Packard Interface Bus Manual, -hp- part number 59401-90090. These manuals are available through your local -hp Sales and Service Office.

Basic Device Communication Capabilities

With HP-IB, devices can be classified as either Controllers, Talkers, or Listeners. These are defined as follows:

a. Controllers. The device that can specify which device(s) connected to the bus is to be a Talker or a Listener. There are two types of controllers: an Active Controller and a System Controller. The Active Controller is the current controlling device. The System Controller can, however, take control of the Bus even if it is not the Active Controller. There can be only one active controller at any given time even if several controllers are connected to the interface.

b. Talkers. A Talker is any device that is able to send information over the Bus when it has been addressed. Only one talker may be active at a time; usually the one that is currently addressed to send data. All HP-IB computers, most HP-IB instruments and of course the 3488A, are Talkers.

c. Listeners. Devices which receive information over the HP-IB interface, when they are addressed to listen are called Listeners. A device may or may not be both a Talker and a Listener. The 3488A has Listener Capabilities.

Interface Terms

The following glossary defines many of the terms and concepts used to describe the HP-IB interface system.

- ▶ Address. Each device connected to the interface has a unique address assigned to it. In HP-IB, the address is generally set by switches on the instrument. The address is used to specify which device connected to the interface will receive (addressed to Listen) or send (addressed to Talk) information.
- ▶ Byte. A byte is a unit of information consisting of 8 binary digits called bits.
- ▶ Clear. The Clear message causes the listening device(s) or all the devices connected to the interface to return to their predefined device dependent state.
- ▶ Device. Any instrument or computer/calculator that is HP-IB compatible is called a Device.
- ▶ Device Dependent. Device Dependent refers to an action a device performs in response to information sent through the interface. The action is characteristic of a particular device and will probably vary with different devices.

- ▶ **Polling.** Polling is a process typically used by a controller to locate a device that has requested service from the controller. There are two types of polling: Serial Poll and Parallel Poll.
 1. **Serial Poll.** When the controller executes a Serial Poll, the addressed device sends one byte of operational information, called a Status Byte, to the controller. If more than one device connected to the interface is programmed to request service, each device must be serial polled until the device that actually requested service is located.
 2. **Parallel Poll.** This method obtains a Status Bit from 8 devices connected to the interface. The 3488A does not respond to a Parallel Poll.

- ▶ **Require Service.** A device can send this message at any time to signify that it needs some type of interaction with the controller. Sometimes it only indicates to the controller that some defined action has taken place. The device must be preprogrammed to send the Service Request (SRQ) and the controller must be preprogrammed to respond.

HP-IB Messages

Different types of information can be passed over the HP-IB to one or more devices. Some of this information is in the form of messages, most of which can be separated into two groups. One group can be classified by the address portion specified by the controller and the information that comprises the message. An example of a message from this group would be: OUTPUT 709;''SLIST100-109''. The second group can be classified as HP-IB management messages. This group is comprised of twelve messages and are called Bus Messages.

- a. **DATA:** The actual information (binary bytes) sent by a talker to one or more listeners. The information (data) can be in numeric form or a character string.
- b. **TRIGGER:** The Trigger message causes the listening device(s) to perform a device dependent action when addressed.
- c. **CLEAR:** The Clear message causes the listening device(s) or all the devices on the HP-IB to return to their predefined device-dependent state.
- d. **REMOTE:** This message causes the listening device(s) to switch from local front panel control to remote program control when addressed to listen.
- e. **LOCAL:** This message clears the REMOTE message from the listening device(s) and returns the device(s) to local front panel control.

f. LOCAL LOCKOUT: This message prevents a device operator from manually inhibiting remote program control.

g. CLEAR LOCKOUT AND SET LOCAL: With this message, all devices are removed from the LOCAL LOCKOUT mode and revert to LOCAL mode. The REMOTE message is also cleared for all devices.

h. REQUIRE SERVICE: A device can send this message at any time to signify the device needs some type of interaction with the controller. This message is cleared by the device's STATUS BYTE message if the device no longer requires service.

i. STATUS BYTE: The Status Byte is an 8-bit byte that represents the current status of a single device on the HP-IB. One bit indicates whether the device sent the REQUIRE SERVICE message and the remaining seven bits are device dependent. This byte is sent from the Talking device in response to a Serial Poll operation performed by the controller.

j. STATUS BIT: In response to a Parallel Poll operation, each device on the HP-IB sets or clears a specified DATA bit. The controller then looks at a complete eight bit byte to determine which device requires service.

k. PASS CONTROL: The bus management responsibility is transferred from the active controller to another controller by this message.

l. ABORT: The system controller sends this message to unconditionally assume control of the HP-IB from the active controller. The message will terminate all Bus communication but does not implement the CLEAR message.

3488A Bus Capabilities

The 3488A interfaces to the HP-IB as defined by the IEEE Standard 488-1978. The interface function subset which the 3488A implements is specified in Table B-1.

Table B-1. 3488A Bus Capabilities

SH1	Source handshake - complete capabilities
AH1	Acceptor Handshake - complete capabilities
T6	Basic Talker, with Serial Poll, no Talk-only mode, unaddressed to Talk when it receives its Listen address
TE0	No Extended Talker capabilities
L4	Basic Listener, unaddressed to Listen when it receives its Talk address
LE0	No Extended Listener
SR1	Service Request - complete capabilities
RL1	Remote Local- complete capabilities
PPO	No parallel Poll capabilities
DC1	Device Clear - complete capabilities
DT1	Device Trigger - complete capabilities
CO	No controller capabilities

HP-IB Worksheet

The HP-IB worksheet (Table B-2) can be used to record the HP-IB capabilities of the HP-IB compatible devices in a system. The sheet may be filled in with the Bus message capability of your controller and for each HP-IB device. The Bus capability of the 3488A has already been filled in. Refer to your controller HP-IB I/O manual and the manual(s) for the other device(s) for their Bus Message capabilities. Once the sheet is filled in, you will then have a complete record of the HP-IB capabilities of your system.

Table B-2. HP-IB Worksheet

Message	Device							
Instrument Identification and HP-IB Address	MODEL 3488A							
	LISTEN YES							
	TALK YES							
	ADDRESS 09							
DATA	S&R							
TRIGGER	R							
CLEAR	R							
LOCAL	R							
REMOTE	R							
LOCAL LOCKOUT	R							
CLEAR LO & SET LOCKOUT	R							
REQUIRE SERVICE	S							
STATUS Byte	S							
STATUS BIT	N							
S - SEND ONLY		R - RECEIVE ONLY		S&R - SEND AND RECEIVE		N - NOT IMPLEMENTED		MODEL LISTEN

INDEX

A	Page
Accessories	101
Actuator	156
Applications, 44470A	11
Applications, 44471A	12
Applications, 44472A	13
Applications, 44473A	15
Applications, 44474A	17
Applications, 44475A	18
Attenuators	125
B	Page
Bit Definition	210
Breadboard Assembly	241
Breadboard Interface Circuitry	19
Breadboard Module	18
C	Page
Card Monitor	66
Card Pair	58,65
Card Reset	65
Card Type	8,64
CHAN	55,68,116,142,171,191,229
Channel Closed	56,118,144,172,193
Channel Closed Example	129,237
Channel Definition	24,110,136,164,184
CLEAR	82
CLOSE	25,63,111,137,166,186,213
CMON	66,117,143,171,191,219
Command Directory	61
Commands	23
Configuration, 44470A	125
Configuration, 44471A	151
Control Keys	3
CPAIR	58,65,114,140,168,188,215
CRESET	65,113,139,168,188,215
CTYPE	8,64,113,139,167,187
D	Page
DBR	71,231
DBW	71,230
DELAY	59,71,119,145,194,230
Digital Binary Read	71,231
Digital Binary Write	71,230
Digital I/O	16
Digital I/O Module	209
Digital Mode	69,220
Display	3,38,77
DMODE	69,220
Documentation Worksheets	259
DREAD	70,218
DWRITE	70,216

E	Page
EHALT	76
End of Scan Sequence, Example	88
ERROR	75
Error Messages	6,40
Errors	39
Event Log	260
Extending the Matrix Example	200
External Increment	56,118,144,172,193,226
External Increment Example	130,237
F	Page
Four-Wire Ohms	127
FRONT PANEL	3
Front Panel SRQ, Example	87
G	Page
General Purpose Relay	135
General Purpose Relay Module	12
H	Page
HP-IB Address	22,99
HP-IB Description	265
HP-IB Interface	99
HP-IB Messages	268
HP-IB Terms	267
I	Page
ID?	73
Input Buffer	79
Installation, 44470A	120
Installation, 44471A	147
Installation, 44472A	175
Installation, 44473A	196
Installation, 44474A	233
Isolation Impedance	177
K	Page
Keyboard	77
L	Page
Limit Switch Sensing	239
LOCAL	82
LOCAL LOCKOUT	83
M	Page
MASK	75
Matrix Switch	15
Matrix Switch Module	183
Mode Definition, Digital	220
MONITOR	28
Monitor Tracking	35

N	Page
Numeric Keypad	3
O	Page
OPEN	25,63,112,138,166,186,214
Operation Keys	3
Options	101
OVERLAP	76,79
P	Page
Polarity	225
Power Requirements	96
Power-on Operations	5
Programming	21
Q	Page
Quick Reference Guide	44
R	Page
RECALL	51,74
Relay Multiplexer	11,109
REMOTE	83
Reset	6,36
RESET	72
Resistance Programming Example	157
S	Page
Safety Summary	103
Scan List	67,115
Scanning	53
Single Ended Measurements Example	131,159
SLIST	53,67,115,141,169,189,227
Slot Definition	24
Specifications	105,242
Specifications, 44470A	134
Specifications, 44471A	155
Specifications, 44472A	176
Specifications, 44473A	200
Specifications, 44474A	237
SPOLL	91
SREAD	252
SRQ	84
SRQ MASK	75,85
STATUS	42,73
Status Register	85
STEP	55,68,116,142,170,190,228
Stop on Error	76
STORE	51,74
SWRITE	253
SYNTAX	44

T	Page
Test	6
TEST	72
Time Delay	59
Topologies	178
TRIGGER	94
V	Page
Varistors	155
VHF Switch	13,163
VIEW	27,64,112,138,167,187,214
W	Page
Warranty	102